



भारत सरकार  
GOVERNMENT OF INDIA  
रेल मंत्रालय  
MINISTRY OF RAILWAYS  
(रेलवे बोर्ड)  
(RAILWAY BOARD)

भारतीय रेल  
INDIAN RAILWAYS  
पुल नियमावली  
BRIDGE MANUAL

1998



## **FOREWORD**

In the "Indian Railways Way and Works Manual" which was last published in the year 1967, the aspect of Bridge inspection and to a certain extent, Bridge maintenance, River and River Training Works and Flood Control were only dealt with. With the advent of modernisation in methods of bridge construction and maintenance, the provisions needed amplification and updating. This has been done now by bringing out a separate "Indian Railways Bridge Manual" where the procedures and practices envisaged in the inspection and maintenance of bridges and other steel structures have been covered, which I hope will help the Engineers in constructing and maintaining bridges and other structures to better standards, ensuring safety, economy, quality and efficiency.

New Delhi  
September 1998.

V. K. AGNIHOTRI  
Member Engineering  
Railway Board.

## PREFACE

The Indian Railways Way and Works Manual was first published in the year 1954. Since then much technological developments have taken place in the field of railway engineering resulting in considerable changes in maintenance practices. The Track Standards Committee vide item No. 678 of the 49th report recommended that revised Manual should be compiled in three parts, for Permanent Way, Bridges and Works. It also recommended appointment of an officer on Special Duty by the Railway Board for this purpose.

Pursuant to the above recommendations, Indian Railways Permanent Way Manual was compiled and published in the year 1986. Thereafter the work of drafting the Bridge Manual was taken up by Shri K.S. Swaminathan, the then Chief Administrative Officer (Construction), Southern Railway who was appointed as Officer on Special Duty. The draft chapters, as compiled, were then scrutinised and finalised by a Select Committee consisting of the following officers:-

Dr. S. R. Agrawal	Director Standards / B. & S., RDSO / Lucknow
Shri. Arvind Kumar	Director Standards / B. & S., RDSO / Lucknow
Shri. N. K. Parthasarathy	Director, IRICEN / Pune.
Shri. M. Ravindra	Director, IRICEN, Pune.
Shri. S. V. Salelkar	Executive Director / Works, Railway Board.
Shri. A. P. Murugesan	Chief Bridge Engineer, Eastern Railway, Calcutta.
Shri. S. Suryanarayanan	Chief Bridge Engineer, SE Railway, Calcutta
Shri. K. K. Bhattacharya	GM / RITES, New Delhi
Shri. J. S. Saigal	GM / RITES, New Delhi
Shri. T. S. Natarajan	Chief Engineer / Constn., Southern Railway, Madras

Shri. A. K. Mehrotra, Executive Director, Civil Engg. (B. & S.), Railway Board attended the meetings as an observer from the Board.

Shri. K. S. Swaminathan, Officer on Special Duty and Chief Administrative officer (Construction), Southern Railway acted as a Member and Convenor of the Committee.

While finalising this Manual, the provisions in the Indian Railways General Rules 1976, the Indian Railways Code for Engineering Department 1993 and the Bridge Rules and Substructure Code have been taken into account.

All efforts have been made to make the instructions comprehensive and exhaustive to cater for every contingency that may arise during the course of working. However, the Chief Engineers of Zonal Railways may supplement or modify, where necessary, the practices and procedures contained herein, with such further instructions or orders as would suit local circumstances on their Railways. Such instructions or orders must not, of course, contravene the provisions of Railway Codes for the different Departments or the General Rules for Indian Railways or any of the statutory regulations in force.

Railway Board will be glad to consider any comments and suggestions from the Railway Administrations.

New Delhi  
September 1998

N. C. BINDLISH  
Additional Member Civil Engineering  
Railway Board

---

# CONTENTS

	PAGE NO.
<b>SCOPE</b>	<b>1</b>
<b>CHAPTER - I</b>	<b>2</b>
<b>DUTIES OF BRIDGE OFFICIALS</b>	
<b>PART A - DUTIES OF ASSISTANT ENGINEER</b>	
101. General	
102. Inspection of Bridges	
103. Inspection of Tunnels	
104. Maintenance of Bridges & Structures	
<b>PART B - DUTIES OF ASSISTANT (BRIDGE) ENGINEER/DIVISIONAL (BRIDGE) ENGINEER IN CHARGE OF BRIDGES IN DIVISION</b>	
105. Inspection of Bridges and other structures	
106. Maintenance of Bridges and other structures	
<b>PART C - DUTIES OF BRIDGE INSPECTOR</b>	
107. Inspection of bridges and other structures	
108. Knowledge of Rules and Regulations	
109. Co-ordination with Permanent Way, Works, and higher staff of other Departments	
110. Accompanying on Inspections of Higher officials	
111. Execution of Works	
112. Action in case of Emergency	
113. Establishment	
114. Correspondence and records	
115. Relinquishment of charge	
<b>PART D - DUTIES OF PERMANENT WAY AND WORKS INSPECTORS</b>	
116. General	
117. Inspection	
118. Maintenance	
<b>CHAPTER-II</b>	<b>12</b>
<b>MAINTENANCE OF BRIDGES</b>	
<b>PART A - GENERAL</b>	
201. Responsibility of the Engineering officials	
202. Action to be taken after inspection of bridges	
203. Painting of Bridges	

---

<b>PART B - MAINTENANCE OF FOUNDATIONS, PROTECTIVE WORKS AND WATERWAYS</b>	
204. Maintenance of foundations	
205. Maintenance of Protective Works	
206. Maintenance of waterways	
<b>PART C - MAINTENANCE OF SUBSTRUCTURE</b>	
207. Abutments, piers, wing walls and return walls	
208. Maintenance of arches	
209. Details of common repair techniques	
<b>PART D - MAINTENANCE OF SUPER STRUCTURE – REINFORCED CEMENT CONCRETE &amp; PRESTRESSED CONCRETE BRIDGES</b>	
210. Periodical maintenance	
211. Common defects and repair/strengthening techniques	
<b>PART E - MAINTENANCE OF SUPER STRUCTURE STEEL GIRDERS</b>	
212. Loss of camber in steel girders	
213. Cracks in steel works	
214. Strengthening of weak girders	
215. Replacement of loose rivets	
216. Corrosion and its prevention	
217. Protective Coatings by painting	
218. Metallising & Epoxy based Paints	
219. Maintenance of welded girders	
<b>PART F - MAINTENANCE OF COMPOSITE GIRDERS</b>	
220. Action taken for maintenance of composite girders	
<b>PART G - MAINTENANCE OF BED BLOCKS</b>	
221. Various defects and their remedies	
<b>PART H - MAINTENANCE OF BEARING</b>	
222. Bearings	
<b>PART I - GENERAL PRECAUTIONS</b>	
223. Precautions while carrying out maintenance works on bridges	
<b>CHAPTER - III</b>	<b>50</b>
<b>INVESTIGATION AND SURVEY FOR CONSTRUCTION OF BRIDGES</b>	
301. Investigation for Minor Bridges	
302. Investigation for Major bridges	
303. Investigation for Important Bridges	

- 
304. Techno economic Feasibility Study
  305. Survey of Rivers in connection with the location of an important bridge
  306. Hydrological Investigation
  307. Plan and Cross Section of Rivers
  308. Factors governing the choice of site
  309. Design discharge (Q)
  310. Design discharge for foundations ( $Q_f$ )
  311. Design of waterways
  312. Vertical Clearance
  313. Free Board (F)
  314. Standard of substructure for new railway lines
  315. Final Project Report in case of important Bridges
  316. Choice of foundations for bridges
  317. Approval of drawings for new lines, doublings and Gauge Conversion

#### **CHAPTER – IV**

**61**

#### **CONSTRUCTION OF FOUNDATIONS FOR BRIDGES**

401. Setting the layout of Bridges
402. Pipe and box culverts with open foundations
403. Other Bridges with open foundations
404. Excavation using Cofferdam
405. Choice of pile materials
406. Soil exploration for design and construction of Piles
407. Classification of Pile Foundation
408. Selection of type of Piles
409. Spacing of Piles
410. Load carrying capacity of a Pile/Group of Piles
411. Construction of Pile foundation
412. Permissible Tolerance while driving Piles
413. Sequence of piling
414. Defective Pile
415. Tremie Concreting
416. Acceptance of Pile
417. Types of well.
418. Components of wells
419. Pitching of the cutting edge and well curb

- 
- 420. Concreting of Steining
  - 421. Sinking of wells in water
  - 422. Sinking of wells using caissons
  - 423. Process of open Sinking of wells
  - 424. Tilt and shift of the well
  - 425. Use of divers for sinking
  - 426. Pneumatic sinking of well
  - 427. Founding the well
  - 428. Bottom plugging of the well
  - 429. Sand Heaving
  - 430. Construction of the top Plug
  - 431. Setting out of the Piers on the top of well
  - 432. Construction of well Cap (Entablature)

**CHAPTER - V**

**84**

**REHABILITATION OF BRIDGES**

- 501. Reasons for Rehabilitation
- 502. Special Strengthening
- 503. Distressed bridges
- 504. Classification of a bridge as "Distressed"
- 505. Imposition of speed restriction
- 506. List of distressed Bridges (LDB)
- 507. Distressed Bridge Diagram
- 508. Priority for rehabilitation of distressed bridges
- 509. Special Inspection
- 510. Site Data
- 511. Execution of rehabilitation works
- 512. Strengthening of foundations
- 513. Strengthening / rebuilding of substructure
- 514. Shaken/displaced/ cracked bed blocks
- 515. Distressed arch bridges
- 516. Replacement of non standard girders
- 517. Replacement of pipe culverts
- 518. Distress in parapets
- 519. Replacement of small opening
- 520. Distress in superstructure
- 521. Replacement of Meter Gauge Bridges



**CONSTRUCTION OF SUBSTRUCTURE AND SUPER-  
STRUCTURE INCLUDING ERECTION OF GIRDERS****PART A - CONSTRUCTION OF SUPERSTRUCUTRE**

- 601. General
- 602. Importance of aesthetics in Construction
- 603. Materials of construction
- 604. Piers, abutments and wing walls
- 605. Construction aspects – General
- 606. Important points in regard to construction of substructure and superstructure

**PART B - CONSTRUCTION OF SUPERSTRUCUTRE**

- 607. Slab Bridges
- 608. Arch Bridges
- 609. RCC/PSC bridges ( beams with slab )
- 610. Erection of PSC girders
- 611. Important points to be borne in mind in the construction of PSC girders
- 612. Quality control in prestressed concrete works

**PART C - FABRICATION AND ERECTION OF STEEL GIRDERS**

- 613. Preparation for fabrication
- 614. Trial Shop Erection
- 615. Preparation of surface
- 616. Field erection
- 617. Welded Girders
- 618. Painting of new Girders
- 619. Choice of a suitable method of girder erection
- 620. Preliminary Arrangements before girder erection
- 621. Erection by use of cranes
- 622. Erection with Derricks
- 623. End launching methods
- 624. Side slewing method
- 625. Launching of triangulated girders on the trestles
- 626. Launching of girders by using service span
- 627. End launching of open web girders with the help of launching nose
- 628. Erection by cantilevering method
- 629. Enveloping method

---

**CHAPTER – VII****124****RIVERS AND FLOODS**

- 701. Behaviour of Rivers
- 702. Past History of Bridges
- 703. Danger level at Bridges
- 704. Watchmen at Bridges
- 705. Duties and Equipment of Bridge watchmen
- 706. Action to be taken by the Permanent way inspector at site
- 707. Special Inspection during Monsoon
- 708. Action to be taken in the case of weather warning
- 709. Pitching stone, boulder and other monsoon reserves
- 710. Floods Records
- 711. Flood Records during monsoon
- 712. Flood records after the monsoon
- 713. Attention to damages
- 714. Rivers and flood register
- 715. Flood Reports
- 716. Rainfall data
- 717. Provision of Anemometer on Bridges

**CHAPTER - VIII****138****RIVER TRAINING AND PROTECTION WORKS**

- 801. Training/Protection of various type of Rivers
- 802. Upper reaches (Mountainous Riverts)
- 803. Submontane reaches (Foot hills)
- 804. Quasi-Alluvial reaches (Trought)
- 805. Alluvial reaches
- 806. Tidal reaches/Deltaic regions
- 807. South Indian Rivers
- 808. River training works
- 809. Guide Bunds
- 810. Spurs (Groynes)
- 811. Marginal Bunds
- 812. Closure Bunds
- 813. Assisted Cut-Offs
- 814. Protection of approach banks
- 815. Design of River training works through Model studies

	<b>CHAPTER IX</b>	<b>148</b>
	<b>FABRICATION, ERECTION, INSPECTION AND MAINTENANCE OF OTHER STEEL STRUCTURES</b>	
901.	Inspection by Bridge Inspector	
902.	Joint inspection of structures in workshops	
	<b>CHAPTER – X</b>	<b>150</b>
	<b>INSPECTION AND MAINTENANCE OF TUNNELS AND DEEP CUTTINGS</b>	
<b>PART A - TUNNELS</b>		
1001.	Inspection by Engineering Inspectors	
1002.	Items to be covered in the Inspection	
1003.	Record of Inspection	
1004.	Inspection by Assistant Engineer	
1005.	By Divisional/Sr. Divisional Engineers	
1006.	Mobile staging for Inspection	
1007(A)	Details of tunnel inspection	
1007(B)	Ventilation of tunnels	
1008.	Leakage in tunnels and methods of correction	
1009.	Works connected with the maintenance of tunnels	
<b>PART B - DEEP CUTTINGS</b>		
1010.	General	
1011.	Inspection Register of Vulnerable Cuttings	
1012.	Points to be noted during inspection of cuttings	
1013.	Action to be taken in the case of boulder drops	
1014.	Action to be taken after inspection of cutting	
1015.	Guarding of Vulnerable Cuttings	
	<b>CHAPTER - XI</b>	<b>163</b>
	<b>INSPECTION OF BRIDGES</b>	
1101.	By permanent way and works inspectors	
1102.	By Bridge Inspectors	
1103.	Inspection by Assistant engineers	
1104.	By Divisional Engineers and Territorial HODs	
1105.	By Assistant Engineer/Divisional Engineer (Bridges)	
1106.	By Dy.Chief Engineer / (Bridges)	
	<b>DETAILS OF BRIDGE INSPECTION</b>	
1107.	Details of Bridge Inspection	

1108.	Special Inspection during Monsoon	
1109.	Equipment required for inspection of Bridges	
	<b>CHAPTER – XII</b>	<b>186</b>
	<b>PLANT AND MACHINERY OF THE ENGINEERING DEPARTMENT</b>	
1201.	Control of plant and machinery	
1202.	Engineering plant Reserve	
1203.	Plant and Machinery for maintenance	
1204.	Plant and machinery procured for works against specific sanction/projects	
1205.	Transfer of plant and machinery on completion of work	
1206.	Plant numbers	
1207.	Register for Engineering plant reserve	
1208.	Valuation of plant	
1209.	Maintenance, storage and repairs to plant	
1210.	Requisitions by Divisional Engineer on plant Depot	
1211.	Use of Engineering reserve plant at site of work	
1212.	Debits for plant and staff supplied on departmental requisitions	
1213.	Maintenance of Log book for Plant	
1214.	Log book on Motor Trollies and Motor vehicles	
1215.	Hiring out of engineering plant	
1216.	Examination of the boilers of the Engineering department	
1217.	Boilers not in use for limited period	
1218.	Laying of boilers	
1219.	Transfer of boilers	
	<b>CHAPTER – XIII</b>	<b>200</b>
	<b>TRAINING FOR BRIDGE STAFF</b>	
1301.	Types of Training Courses	
1302.	Initial courses	
1303.	Promotional courses	
1304.	Refresher courses	
1305.	Special courses	
	<b>CHAPTER XIV</b>	<b>207</b>
	<b>BOOKS OF REFERENCES</b>	
1401.	Books of references	
1402.	Circulation of Technical papers	



---

## LIST OF ANNEXURES

<b>Annexure</b>	<b>Particulars of sketch/proforma</b>	<b>Para reference</b>
2/1	Provision of Bridge number on Parapet wall	203
2/2	Curtain wall, Drop wall and flooring	204
2/3	Toe wall and pitching	205
2/4	Cracks in arches – types	208
2/5	Cracks in arches - types	208
2/6	Pressure grouting machine	209
2/7	Cement pressure grouting	209
2/8	Epoxy grouting	209
2/9	Guniting machine	209
2/10	Sliding centralized bearings	222
2/11	Roller & Rocker bearings	222
2/12	Elastomeric and PTFE bearings	222
4/1	Method of setting out a multiple span bridge without a base line	401
4/2	Method of setting out a multiple span bridge with the help of a base line	401
4/3	Arrangements for founding pipe culvert	402
4/4	Typical section of abutment & Pier with Open and Raft Foundation	403
4/5	Excavation with shoring	403
4/6	Single wall sheet pile coffer dam	404
4/7	Double sheet pile coffer dam	404
4/8	Temporary wooden pile bridge	405
4/9	Rig used for driving precast piles	411
4/10	Construction of bored cast in-situ pile using Bentonite slurry	415
4/11	Cross section of a well foundation	418
4/12	Typical RCC well curb	418
4/13	Island for construction of well in water	421
4/14	Assembly of caisson at site of pier	422

4/15	Arrangement for grounding of caissons	422
4/16	Type of rail chisels used in well sinking	423
4/17	Sand blow in a well	423
4/18	Methods of tilt correction	424
4/19	Typical air lock arrangement	426
4/20	Founding of wells on rock	427
4/21	Top plug and well cap	430
5/1	Distressed bridge diagram	507
5/2	Replacement of cast iron screw piles by bored piles	512
5/3	Strengthening of piers/abutments	513
5/4	Encasement and replacement of bed block	514
5/5	Rehabilitation of arch bridges by various methods	515
5/6	Rehabilitation with slabs	516
5/7	Box pushing technique	517
5/8	Rehabilitation of parapets	518
6/1	Types of piers	604
6/2	Types of abutments, wing walls and returns	604
6/3	Back fill material and Weep holes behind abutments	605
6/4	Sequence of work in an arch	608
6/5	Erection by use of launching girders and cantilever method	610
6/6	Cantilever launching and incremental launching of precast elements	610
6/7	Erection with derrick	622
6/8	Launching with rail clusters	623
6/9	Launching by Diploory and "Linking and rolling" (by skidding)	623
6/10	Use of BFR and launching pad in launching	623
6/11	Use of trestles and service span in launching	625 & 626
6/12	Use of launching nose and Derrick crane for launching of girders	627 & 628
7/1	Proforma for recording gauge, afflux and velocity	711
7/2	Cross section of river bed after floods	711 & 712
7/3	Survey plan of river	712

7/4	Cross section of guide bunds	712
7/5	Proforma of flood reports	715
7/6	Rain fall statement	716
8/1	Braiding pattern in rivers	803
8/2	Meander pattern in alluvial rivers	805
8/3	Different forms of guide bund	809
8/4	Layout of a guide bank	809
8/5	Types of spurs	810
9/1	Proforma of structural steel inspection register	901
10/1	Proforma of Tunnel inspection register	1003
10/2	Proforma of vulnerable cutting register	1011
11/1	Proforma of inspection register for steel work in bridges	1102
11/2	Proforma of inspection for steel work in bridges of 12.2m & above	1102
11/3	Instructions to be printed in bridge inspection register	1103
11/4	Index of bridges	1103
11/5	General key plan for Bridge Inspection Register	1103
11/6	Details of classification of structures	1103
11/7	Details about inscription plaques	1103
11/8	Proforma of bridge register for Major and Important bridges	1103
11/9	Proforma of bridge register for inspection of Major & Important bridges	1103
11/10	Proforma of bridge register for details of Minor bridges	1103
11/11	Proforma for inspection of Minor bridges	1103
11/12	Procedure for rivet testing	1107
11/13	Sample rivet test register	1102 & 1107
11/14	PSC girders camber measuring method	1107
11/15	Details of tools and equipment for inspection of bridges	1109
12/1	Proforma of form of agreement for hire of plant	1215
14/1	List of books of reference	1401

## SCOPE

---

### **Scope**

The scope of Indian Railways Bridge Manual is to bring out the practices and procedures for maintenance of bridges on Indian Railways. For design and construction purposes, the provisions of relevant IRS Codes will override those provided in this manual wherever the two contravene each other.



## **CHAPTER - I**

### **DUTIES OF BRIDGE OFFICIALS**

#### **PART A - DUTIES OF ASSISTANT ENGINEER**

##### **101. General**

1. The Assistant Engineer is generally responsible for the maintenance and safety of all way & works including bridges in his charge; for the accuracy, quality and progress of new works and control over all expenditure in relation to budget allotment.

2. The duties of the Assistant Engineer are detailed in various chapters of Indian Railways Permanent Way Manual, Works Manual and Bridge Manual. His essential duties in respect of bridges and other steel structures are detailed here under,

##### **102. Inspection of Bridges**

a) The Assistant Engineer shall inspect every Bridge including Road over / under Bridges once a year by a date specified by Chief Engineer after monsoon. This inspection shall cover,

- i) Foundation and flooring, substructure, protective works, bed blocks, track over bridges and the approaches including guard rails and other appurtenances of all Bridges; pipes, RCC Boxes, superstructure of arches, RCC & PSC slab bridges etc.
- ii) General condition of steel work of girders and bearings with special attention to places liable to corrosion.
- iii) General condition of all RCC, Composite and PSC girders and their bearings.

b) He will inspect Distressed Bridges as detailed in para 509.

c) Wherever necessary, he shall jointly inspect canal and irrigation crossings with his counter part of State P.W.D. or Irrigation Department.

d) The inspection of bridges shall be carried out as per Chapter XI.

e) He should send extracts of the orders regarding action to be taken by the Inspectors arising out of his inspection for compliance with a copy to Divisional Engineer.

f) He should submit the Bridge registers with his certificate of completion of Bridge inspections to his Divisional Engineer

g) He shall arrange to maintain the flood records upto date as detailed in Para 710. He will also maintain the Rivers and Flood register as detailed in Para 714.

**103.** He shall inspect every tunnel in the sub division once a year before monsoon and maintain the records of his inspection.

**104. Maintenance of Bridges and Structures**

1. He shall be responsible for the maintenance and repairs to foundations, flooring, sub structures, protective works, bed blocks, track over bridges and the approaches including guard rails and other appurtenances, pipes, RCC Boxes, superstructure of all arches, RCC and PSC slabs, steel work of girder spans less than 12.2 m clear and other type of bridges except composite, RCC, PSC and steel girders of spans 12.2 m and more.

2. All other steel structures like FOB, Sheds / Shelters etc.

3. He should arrange for the expeditious repairs, as and when required.

**PART B**

**DUTIES OF ASSISTANT (BRIDGE) ENGINEER/  
DIVISIONAL (BRIDGE) ENGINEER  
IN CHARGE OF BRIDGES IN DIVISION**

**105. Inspection of Bridges and other structures**

1. The officer nominated to be in charge of the Bridges shall scrutinise the Bridge Inspection register sent by Bridge Inspector and after necessary inspection of Bridges endorse a certificate of scrutiny and forward it to the Dy. Chief Engineer/Bridges by a nominated date.

2. He shall inspect

a) All overstressed girders where camber loss is noted & such bridges which have been referred to him by BRI.

b) Such bridges which call for his inspection, based on scrutiny of the Bridge Inspector's registers.

c) 10% test check of the bridges inspected by Bridge Inspectors every year.

3. He will inspect all such steel structures as ordered by the Chief Engineer at specified intervals.

**106. Maintenance of Bridges and other structures**

1. He will be responsible for

a) Painting, rivetting, welding and other repairs to the steel work of all girder bridges of clear spans 12.2 m and above and also for repair and maintenance of the superstructure of all prestressed concrete, composite and RCC girder bridges.

b) The maintenance of bearings of all girder bridges including oiling and greasing.

c) He will render help to the Divisional (open line) staff for heavy repairs of steel work in girder spans of less than 12.2m clear as cannot be taken by Divisional staff.

2. He will also maintain the other steel structures as ordered by the Chief Engineer.

**PART C**

**DUTIES OF BRIDGE INSPECTOR**

**107. Inspection of bridges and other structures**

1. He is responsible for carrying out detailed inspection of :

a) All welded, RCC, PSC and composite girders and their bearing within one year of installation.

b) Girders kept under observation, once a year or at intervals specified by the Chief Bridge Engineer.

c) Floor system of early steel girders once a year.

d) Superstructure including bearings of all Steel girders of span 12.2 m and above, RCC, PSC and composite girder bridges once in five years on planned basis.

e) Other nominated steel structures, being maintained by him, once in five years.

2. Records of inspection :

He will record the details of each one of the inspections in the register maintained for the purpose as detailed in chapter XI.

3. Maintenance of bridges and other structures :

He shall maintain the following structures in good condition by taking immediate action to carry out necessary repairs, painting, oiling and greasing, etc.

- a) Superstructure and bearing of all Steel bridges of span 12.2m and above, PSC, RCC and composite girders.
- b) Other steel structures as specified by Chief Engineer.

4. He will be responsible for the erection of steel girders for all major bridges, PSC girders.

5. He will be responsible for the erection of workshop structures and Flood light towers, if ordered by the Chief Engineer.

6. He will be responsible for the accountal and periodical verification of stores, tools and plants in his charge.

**108. Knowledge of Rules and Regulations**

1. Every Bridge Inspector shall have in his possession copies of the following codes and manuals with all upto date correction slips :

- i) Indian Railways Permanent way Manual, Bridge Manual and works Manual,
- ii) Indian Railway General and Subsidiary Rules,
- iii) Indian Railway Code for the Engineering Department,
- iv) Schedule of dimensions,
- v) Circulars issued by the higher authorities.

2. He shall be well acquainted with the rules, regulations and procedures concerning his work and duties as enjoined in the above codes and manuals. He shall keep himself in touch with the orders and circulars issued by higher authorities from, time to time and efficiently act upon them.

3. He shall ensure that all staff working under him are well acquainted with the relevant rules and working methods and efficiently perform their duties. They should be examined periodically as specified, on appointment, and on promotion.



**109. Co-ordination with Permanent way, works and staff of other Departments**

The Bridge Inspector should keep close co-ordination with the staff of way, works, signalling, electrical, traction and other departments, when they are required to work jointly.

**110. Accompanying on Inspections of Higher officials**

When the Bridge Inspector accompanies a periodical/ special inspection by the higher officials, he should have with him the following registers and documents pertaining to his section, other than the codes and manuals mentioned in para 108.

- a) Relevant Working Time Tables
- b) Inspection registers for steel work for bridges
- c) Rivet testing register
- d) Weld test register
- e) RCC, PSC Bridge/ Composite Girder, Bridge Inspection register
- f) Annual inspection register for overstressed girders
- g) Up to date plans and files of bridge rehabilitation or regirdering works in progress and which are being inspected.

**111. Execution of works**

1. Working under traffic :

a) He should take every precaution that works under traffic such as repairs and renewals of girders are carried out safely and in accordance with the rules for protection of the line.

b) Before starting any work he shall ensure that he is in possession of all necessary materials and tools.

c) He should make careful inspection of all temporary stagings provided and ensure that they are safe for the intended purpose.

d) He should ensure that Engineering signals are exhibited at specified distances according to rules and flagmen are posted with necessary equipment.

2. Works affecting moving dimensions - The Bridge Inspector shall refer any work likely to affect track or moving dimensions to the Assistant Bridge Engineer and Assistant Engineer for instructions.

3. The Bridge Inspector shall send in advance a programme of his work during the ensuing week to all the officers concerned.

4. Special duties -The Bridge Inspector shall carry out as and when required, such works as measurement of stress under load, verification of impact and oscillation effects and preparation of sketches for girders and other classes of steel work.

5. Tools and equipment - The Bridge Inspector shall ensure that all tools and equipment such as compressors, pneumatic tools, derricks and jacks are used with due care and maintained in efficient working order.

Returns of tools and plant in his charge should be submitted on the prescribed dates.

#### **112. Action in case of emergency**

On receipt of intimation of the occurrence of an accident (including breaches) affecting any part of the bridge or approaches or restricting free passage of trains, the Bridge Inspector should proceed to site by the quickest available means. On the way he should collect information regarding the damage, the men and material requirement at site for restoration and arrange for their movement and seek instructions regarding the restoration from the Assistant Engineer.

#### **113. Establishment**

##### **1. Maintaining of Muster**

a) Each blank muster sheet before issue shall be initialled on the top by the Divisional Engineer/Assistant Engineer (Bridges). The attendance of artisans and helpers and other staff under him shall be checked by the Bridge Inspector according to instructions issued by the administration from time to time.

For each wage period the muster sheets should be collected and fresh ones issued.

b) The leave availed by each man should be recorded in the leave register to his account before the musters are despatched to the Assistant / Divisional Engineer's (Bridge) office.

##### **2. Witnessing payments to staff**

a) Payment to both permanent and temporary staff on the section

will be made by the pay clerk in the presence of the Bridge Inspector who will witness and will be responsible for correct identification of the payee and should satisfy himself that the correct amount is paid.

b) The certificate at the foot of the paysheet should be filled in by him as payment of each batch of workmen is completed, specifying both in words and figures the amount paid on each date. If a person is not present, "Not Paid" should be immediately written against his name; when subsequently payment is made, the kilometrage (mileage) or place at which he is paid should be entered and separately certified as such on the pay sheet.

c) If the Bridge Inspector working in the section is not readily available, another Inspector may be authorised by AEN (Bridges) to witness payment on the section.

### 3. Other establishment matters

a) General conditions of railway service and rules relating to the conduct and discipline of railway servants are contained in the relevant chapter of the Indian Railway Establishment Code.

b) Medical examination - The bridge inspector should ensure that all staff including casual labour are sent for medical examination on appointment, promotion and for periodical medical examination as laid down in the relevant rules.

c) Service Cards : He will arrange to maintain the service cards/ leave account of all the permanent staff working under him. Service card should be prepared as soon as appointments to permanent vacancies are made. In the case of casual labour he will arrange to issue the necessary service card to them and will maintain the L.T.I. register. All increment and promotions should be noted in the service cards and duly attested by the Assistant Engineer/Divisional Engineers (Bridges).

#### d) Provision in the various acts :

He will ensure that the relevant provisions of payment of wages Act, Workmen's Compensation Act, Contract labour regulation and abolition act, Industrial Disputes Act and rules made thereunder, Hours of Employment Regulations, etc. as amended from time to time are complied with.

- e) Promotion to higher grades :
  - i) The Bridge Inspector should maintain, in manuscript form, records of staff working under him in which he shall enter merits and demerits of each as and when such entries are justified.
  - ii) The normal procedure for promotion should be by "Trade Tests." Qualified men will be entitled to promotion by seniority within their own groups.
  - iii) He will initiate prompt action for filling up the vacancies by referring to the Assistant engineer/Divisional Engineer (Bridges).
- f) He will arrange to carry out the other establishment work such as issue of passes, preparation of pay bills etc. as may be allotted to him by the administration.
- g) He will ensure proper training of the artisan and other skilled men working under him at the appropriate time.

#### **114. Correspondence and records**

The Bridge Inspector shall keep his correspondence and plans upto-date and ensure that the office records, registers and store ledgers are maintained systematically and posted regularly.

#### **115. Relinquishment of charge**

- a) On relinquishing charge of section the Bridge Inspector shall prepare, in duplicate, the specified "transfer of charge" statement which will briefly contain the following:
  - i) Extent of charge
  - ii) Important works in progress, showing position of each work and any special features to which particular attention is required.
  - iii) Details of inspection planned for year and extent of inspections completed.
  - iv) Certificate of store check and correctness of stock.
  - v) Establishment (Service and leave records)
  - vi) General notes about his section.
- b) The relieving Inspector will examine all books and registers to see that they are upto date and initial them with date.

c) The Bridge Inspectors handing over and taking over charge should together travel over the whole section, inspect all the works in progress and check staff, all tools, plants and materials.

d) The "Transfer of charge" statement should be signed by both the Bridge Inspectors and forwarded to the Assistant Engineers (Bridges) or Divisional Engineer (Bridges) as may be prescribed.

Errors and discrepancies which are noticed should be recorded in the statement and special attention of Assistant Engineer/Divisional Engineer (Bridges) invited to them.

### **Part D**

## **DUTIES OF PERMANENT WAY AND WORKS INSPECTORS**

### **116. General**

While Chapter I of Indian Railways permanent Way Manual and Chapter I of Indian Railways works Manual deal with the duties and responsibilities of PWI and IOW with respect to permanent Way and Works respectively, the following paras deal with their duties and responsibilities with regard to bridges & tunnels.

### **117. Inspection**

1. Once a year during prescribed months prior to monsoon, Permanent Way Inspector or Inspector of Works, as per the practice on the railways, shall inspect every bridge including ROB/RUB in his section covering the following:

- a) Foundations, Substructures and bed blocks of all bridges.
- b) Protective works.
- c) Superstructures of all RCC and PSC slab bridges and masonry bridges.
- d) Detailed inspection of steel work of girders less than 12.2m clear span once in 5 years.
- e) General condition of superstructure of all other type of bridges and their bearings.
- f) Obstruction to water ways, if any.
- g) Tunnels in his section - to be inspected after monsoon.

He will record the details of his inspection in manuscript register in the prescribed proforma and submit a certificate of inspection to the Assistant Engineer by the prescribed date.

2. Inspection by Permanent Way Inspector specifically :

Once a year during prescribed months prior to monsoon, Permanent Way Inspector shall inspect :

- a) The track and approaches of all bridges.
- b) Run off frames and foot-paths over bridges, if any.

**118. Maintenance**

1. Permanent Way Inspector or Inspector of Works, as the case may be, shall be responsible for the up-keep and maintenance of all the items of bridges mentioned in para 117. He shall also be responsible for the maintenance of bridge appurtenances like notice boards, name boards, trolley refuges, sand bins and marking of HFLs etc.

2. The Permanent Way Inspector shall also be responsible for the posting of bridge watchman, wherever necessary and ensure their effective functioning.

□□□

## CHAPTER - II

### MAINTENANCE OF BRIDGES

#### PART A - GENERAL

#### 201. Responsibility of the Engineering officials

##### 1. Permanent Way / Works Inspector:

Different Railways follow different practices in regard to the responsibility of upkeep and maintenance of bridges including road under/over bridges. The maintenance of the items in following sub para should be carried out by Inspector of Works or Permanent Way Inspector in his jurisdiction as per the practice or as approved by the Chief Engineer of the Railway.

a) Foundations, flooring, substructures, bed blocks and protection works of all bridges.

b) Superstructure of all arch, pipe, box, PSC slab and RCC slab bridges.

c) Steel work of girder spans less than 12.2m clear.

##### 2. Permanent Way Inspector:

The Permanent Way Inspector shall be responsible for the maintenance of track over bridges and on the approaches. He shall also be responsible for the maintenance of the appurtenances such as guard rails, foot path, Notice Boards, Name Boards, trolley refuges and sand bins etc. He shall also ensure clearing of waterways of bridges.

##### 3. Bridge Inspectors:

The Bridge Inspector shall be responsible for the maintenance of:

a) The steel work of all the girder bridges with clear span of 12.2m and above

b) Superstructure of all RCC, prestressed concrete and composite girder bridges and

c) The bearings of all the above bridges.

#### 202. Action to be taken after inspection of bridges

1. All repairs as and when required should be executed expeditiously.



2. The Divisional/Senior Divisional Engineer and his officials including the Assistant Engineer shall arrange to carry out maintenance of and repairs to

a) Foundations, flooring, sub structures, protection works, bed blocks, track over bridges and the approaches including guard rails and other appurtenances, superstructure of all arch, pipe, RCC Box, and RCC slab bridges, PSC slab bridges and steel work of girder spans less than 12.2m clear.

b) Marking of HFL, Danger level, foundation detail and other particulars.

c) Clearing of waterway and encroachments.

3. The Divisional Engineer (Bridges) / Assistant Engineer (Bridges) and his officials shall be responsible for the painting, rivetting, welding and other repairs to the steel work of all girder bridges of clear span 12.2m and above, all prestressed concrete bridges (except slabs), composite girder bridges and RCC girders. They shall also be responsible for the maintenance of bearings and holding down bolts of all bridges.

### **203. Painting of Bridges**

1. The date of painting of steel work should be painted in white on the outside of the left girder of the first span. In the case of important girder bridges, the left girder at each end should bear the date of painting.

2. The highest flood level line should be painted distinctly by a 25mm broad white line along with the year of its occurrence, in figures 100mm deep as follows:

a) For bridges upto 60 metres in length, on the downstream side of one abutment,

b) For bridges over 60 metres in length, on each of the abutments on the down stream side or on the down stream side of the piers of the end spans,

c) For buried type abutments, on the piers near the end spans.

3. At important bridges, Flood level gauges should be provided on abutments or on piers of the end spans. The marking should be in

metres divided into ten parts commencing from the underside of the girders towards the bed. The marking and the figures should be painted in black on white back ground, where necessary piers and abutments may be plastered with cement mortar 380 mm wide for providing the gauges. The H.F.L. mark in white paint should be made by the side of the gauge.

4. The direction of flow should be distinctly marked in white on an abutment or pier.

5. Plaques showing particulars of foundations should be fixed over every abutment and pier in accordance with instructions contained in Annexure 11/7.

6. Name boards at important bridges should be fixed at either approach at a distance of about 15 metres from the abutment indicating the name of the river and the number and length of spans.

7 Plaques containing Bridge numbers and indicating direction of flow should be provided on parapet wall as detailed in Annexure 2/1.

8. At all Canal crossings, the Full Supply Level should be marked distinctly in the same way as the H.F.L. line for other bridges.

9. Danger level should be distinctly marked in red in all the bridges as stipulated in para 703.

## **PART B**

### **MAINTENANCE OF FOUNDATIONS, PROTECTIVE WORKS AND WATERWAYS**

#### **204. Maintenance of foundations**

##### 1. Shallow foundations

a) A bridge foundation having less than 2M depth below bed level in case of arch bridges and 1.2M depth below bed level in case of other bridges is termed as shallow foundation.

b) Bridges with shallow foundations in sandy soils or soils likely to scour should be protected by stone, brick on edge or CC flooring with drop walls and/or curtain walls to protect foundation from scour (Annexure 2/2). This method is generally suitable in cases where the velocity of flow does not exceed 1.5 metre per second and afflux is negligible. The top level of the flooring, drop and curtain walls should be kept at the normal bed level of the stream or slightly lower to allow for

the retrogression of the bed of the stream. Any damage to the flooring should be rectified in time, as failure to do this will lead to further damage during subsequent floods.

c) Whenever heavy scour is noticed on the downstream of the drop walls, scour hole should be filled with boulders or wire crate filled with boulders.

## 2. Deep foundations :

a) A foundation which is deep enough, having required grip length below maximum scour level is termed as deep foundation. Normally no protection is required for such foundations.

b) The river bed between piers should not generally be pitched, as the pitching stones if washed away, may lead to excessive scour down stream, resulting in damage to piers.

c) If warranted by actual conditions, piers and abutments on these bridges can be protected individually by pitching stones around them. Depending upon the velocity of the current under the bridge, proper sized stones or stones filled wire crates can be dumped below low water level. The boulders should be of proper size which could be handled manually but could not be carried away by water current. The pitching will be best done during dry season or when stream is at low water level.

d) In very severe cases of scour, piles are driven concentric to the foundation with boulders dumped in-between. Sausage crates containing boulders may also be placed in the scoured portion around the piles.

## 205. Maintenance of Protective Works

1. Meandering rivers during high floods may out flank and damage bridge and approaches. To control the same, following protective works are provided, singly or in combination.

- |                   |                   |                      |
|-------------------|-------------------|----------------------|
| a) Guide bunds    | b) Marginal bunds | c) Spurs/groynes     |
| d) Aprons         | e) Closure bunds  | f) Assisted Cut offs |
| g) Approach banks |                   |                      |

Details including the maintenance practices to be followed for maintaining these works are given in chapter VIII.

2. Pitching :

a) To prevent erosion, stone pitching may be provided on the approach banks, marginal bunds, and at closure bunds. Disturbed pitching should be reset properly by making up the slopes if necessary.

Slope pitching are rested on toe wall with proper foundation. Damaged toe wall can lead to slipping of pitching, and therefore, it should be rebuilt with a proper foundation (Annexure 2/3).

**206. Maintenance of waterways**

1. Obstructions in waterways should be cleared away on both sides of the line within railway limits for the full extent of the waterway.

2. Boundary pillars on each bank of a river or important waterway shall be erected so as to prevent and control encroachments.

**PART C**

**MAINTENANCE OF SUBSTRUCTURE**

**207. Abutments, piers, wing walls and return walls**

During service, the substructure may develop various defects. Their likely causes and the suggested remedies are outlined below :

1. Weathering :

Weathering normally occurs due to adverse environmental conditions prevailing over long periods of time. Structural elements which undergo alternate drying and wetting are also prone to exhibit weathering damage. This will be indicated by layers of material spalling off. As a remedial measure, weathered material should be removed, surface exposed and thoroughly cleaned. If the weathering is not deep, plastering with cement mortar will suffice. Otherwise, guniting or cement or epoxy grouting may be resorted to. For substantially weathered joints, pointing with cement mortar should be done.

2. Leaching of mortar :

Lime and cement mortar with free lime content, deteriorate with time due to action of rain and running water and lose their binding power gradually. If on raking out such joints the material comes out easily and is powdery, it is sure indication of loss of mortar strength.

Tapping of such masonry will give hollow sound indicating leaching out of mortar from deep inside the structure. In case of deep leaching, grouting by cement or epoxy mortar followed by pointing of joints can be tried. However, for surface leaching, the joints should be thoroughly cleaned and pointing done with cement mortar.

### 3. Leaning / Bulging of abutments, wing walls & return walls :

The abutments, wing wall & return wall may bulge or lean due to either excessive back pressure or under mining of foundation. The excessive earth pressure could be due to either buildup of hydrostatic pressure caused by choked weep holes or excessive loading (static / dynamic) beyond design capacity.

a) To avoid build up of hydrostatic pressure following steps should be taken :

- i) Weep holes be provided at 1m interval in both horizontal and vertical directions if not already provided. The bottom most row of weep holes should be above low water level in case of flowing streams; 25 cm above bed level in other cases & above FSL in canal bridges.
- ii) Adequacy of existing weep holes be checked and if required, additional weep holes of proper size be provided.
- iii) Choked weep holes be cleaned and made functional.
- iv) The back fill material should be granular and should not contain expansive soil like black cotton soil etc. Proper filter layer be provided behind the masonry. The back fill material should be changed if so warranted.

b) The excessive earth pressure can be taken care of by either providing masonry or cement concrete buttress. However, care should be taken that the reduction in water way, if any, does not adversely affect the parameters like afflux, clearances etc.

c) For tackling undermining/scour and other rehabilitation problems para 204 and 513 may be referred to.

### 4. Cracks in masonry / concrete :

Cracks may occur due to loss of strength of masonry / concrete

because of age, excessive dynamic impact and settlement or any other damage to foundations.

a) Vertical cracks :

Vertical cracks may occur due to differential settlement of the foundation or excessive shearing stresses in the substructure. The cracks should be monitored by providing tell tales. If these show signs of propagation, a detailed study should be made to identify the causes before taking remedial measures.

b) Horizontal cracks :

These are more serious and these could be due to inadequacy of section, defect in construction, failure of back fill drainage or excessive horizontal loads etc. The remedial measures should be decided after identifying the cause, based on results of analytical study and field observations. Generally grouting with cement or epoxy mortar and jacketing are used as remedial measures.

**208. Maintenance of arches**

Following defects are generally associated with arch bridges.

1. Defects in arch barrel proper :

Due to ageing and weathering effect arch masonry or concrete may show sign of deterioration by way of leaching of joints, spalling of concrete and weathering of masonry. These are to be attended when noticed. Following defects need special attention.

- i) Extension of cracks from substructure to arch barrel : As arch is resting on substructure, the cracks in substructure due to differential settlement etc. may extend through the arch barrel also and may appear as longitudinal cracks (cracks parallel to the direction of traffic) (Annexure 2/4). These cracks are to be grouted with cement / epoxy mortar and tell tale provided to observe further propagation if any. The reasons of unequal settlement should be identified and remedial measures taken.
- ii) Transverse or diagonal cracks in arch barrel (intrados) (Annexure 2/5)

These cracks are serious in nature and indicate presence

of tensile stresses at the intrados. These are generally noticed in the vicinity of the crown of the arch in the initial stages. They have a tendency to progress in diagonal / zigzag direction in stone masonry arches. These cracks indicate serious weakness in the arch and need proper investigation and adoption of appropriate strengthening measures including rebuilding in worst cases.

iii) Crushing of masonry :

The probable causes of crushing of masonry of the arch and remedial measures are as follows :

<b>Probable Cause</b>	<b>Remedial Action</b>
a) Leaching of mortar in the joints.	Raking out the mortar and deep pointing / grouting
b) Weathering of masonry	Pointing together with grouting
c) Excessive loading	Reducing the imposed load or strengthening the arch
d) Inadequate cushion over arch.	Providing the minimum cushion or strengthen the arch.

iv) Loosening of keystone and voussoirs :

This may happen due to settlement / tilting of the abutment/ pier, hammering effect of dynamic load due to inadequate cushion and loss of jointing material. The remedy lies in strengthening the foundation, increasing the cushion, reduction in load transfer, improvement in track structure and deep pointing of the joints as the case may be,

v) Longitudinal cracks in arch away from spandrel wall:

These cracks may occur due to differential deflections of the part of arch barrels subjected to live load and the remaining part. Such cracks may be seen between the adjacent tracks or between the track and spandrel walls. They may also be due to differential settlement of foundation. The underlying cause should be identified and appropriate remedial action taken.



2. Defects associated with spandrel wall :

Various types of cracks associated with spandrel wall, their symptoms, causes and remedial measures are listed below.

<b>Defect</b>	<b>Cause(s)</b>	<b>Remedial measure</b>
a) Longitudinal crack in the barrel along the inner face of the spandrel wall which do not widen with time. (Annexure 2/4)	i) Large difference in stiffness between deep spandrel wall and barrel. ii) Excessive back pressure on spandrel due to inadequate drainage.	i) Cement / epoxy grouting and monitoring. ii) Improving drainage of fill by clearing weep holes/providing new weep holes; providing granular back fill.
b) Cracks mentioned in (a) which widen with time	i) Excessive back pressure on spandrel due to drainage. ii) Excessive surcharge load.	i) Same as a (ii) ii) Reducing over burden. iii) Grouting the cracks with cement/epoxy mortar after carrying out above measures singly or in combination as required.
c) Sliding of spandrel wall over arch barrel; bulging or tilting of spandrel wall.	i) Excessive back pressure on spandrel wall due to poor drainage. ii) Excessive surcharge load iii) Spandrel wall not monolithic with arch.	i) Same as a (ii) ii) Same as b (ii) iii) Tying the spandrel walls with tie bars and rails iv) Same as b (iii)

<p>d) i) Cracks on the face of the bridge at the junction of spandrel and arch ring. (Annexure 2/5) ii) If the above cracks open under traffic.</p>	<p>i) Rib shortening. ii) Distortion of arch ring. iii) Excessive back pressure. i) Rib shortening ii) Distortion of arch ring. iii) Excessive back pressure.</p>	<p>i) Same as a (ii) ii) Same as b (ii) iii) Same as b (iii)  i) Same as "d' above. ii) Strengthening of arch.</p>
<p>e) Cracks in spandrel wall above pier (Annexure 2/5)</p>	<p>Sinking of pier</p>	<p>Remedial measures for arresting sinking of foundation and grouting cracks there after.</p>

3. Leaning of parapet wall :

This is caused by excessive back pressure which may be due to inadequate barrel length, lack of or poor drainage. Wherever feasible the drainage be improved and if required barrel should be extended with a new parapet wall. Where extension is not feasible the parapet wall should be strengthened or rebuilt or ties provided to check the leaning.

4. General instructions for maintenance of arch bridges :

a) Rail joints on the arch should be eliminated completely. In multiple span arches, these should be located over the haunches.

b) Flat bottom sleepers should preferably be used over the arches.

c) Clean ballast cushion should be ensured by periodical screening as necessary. It will be preferable to maintain minimum cushion over the arch by suitably regrading the track wherever feasible.

d) For arch bridges on curves, it should be ensured that the track is centrally located. Where it has shifted towards the outside parapet over a course of time, it should be slewed back to the correct location to ensure equitable distribution of load.

e) While carrying out repair works for existing arches, the filling should not be disturbed as far as possible, as the compacted fill over the arch relieves the arch ring of a portion of the superimposed load.

f) If warranted by circumstances, whenever an arch bridge is opened for rehabilitation purposes, the extrados of the arch should be made water proof. A porous filling such as brick bats, ballast, etc. should then be used to cover the whole of the extrados to a depth of 300mm. The haunches over the piers should be filled with impervious material such as lean cement concrete with proper cross slopes leading to weep holes located at the top of the haunch filling. The earth filling over the porous material should be done in layers, properly consolidated by ramming. Black cotton soil should in no case be used for filling purpose.

### **209. Details of common repair techniques**

The techniques commonly used for repairs of masonry are described below :

#### **1. Cement pressure grouting**

- a) This technique is used
  - i) When cracks are dormant
  - ii) Cracks are active but cause of cracking has been determined and remedial action has been taken.
  - iii) When honey combing is present in concrete structures.
  - iv) When masonry is hollow.
  - v) When deep leached mortar joints are present.
- b) Materials proportion and pressure :

Ordinary Portland cement to IS :269, sand and water conforming to IRS Concrete Bridge Code, are required. With the approval of the Divisional Engineer, admixtures to impart non- shrinkable properties and to improve flowability of grout, may be added. The method of using admixture may be as per the manufacturer's recommendations. The water-cement ratio (by weight) for the grout should be 0.4 to 0.5, the lower ratio being used when crack width exceeds 0.5mm. The grouting pressure should be 2 to 4 kg/cm<sup>2</sup>.

c) Equipment used :

The equipment required for cement pressure grouting are :

- i) Air compressor with a capacity of 3 of 4 cum. per minute and with a pressure of 2 to 4 kg per sq. cm.
- ii) Grout injecting machine or grouting pump with inlet and outlet valves and pressure gauges. This can be power or hand driven.
- iii) An air tight, pressure mixer chamber, with stirrer for proper mixing of the grout and keeping it in proper colloidal suspension during grouting.
- iv) Flexible pressure hose pipes for transmitting grout from pressure chamber to ports embedded in the masonry.
- v) Drilling equipment, pneumatic or electric, for drilling of holes upto 25mm dia.
- vi) 12-20mm dia. G.I. pipes with couplers.

A typical arrangement of pressure grouting equipment is shown in Annexure 2/6.

d) Procedure for cement grouting :

- i) Holes are drilled in structure along cracks and in and around hollow spots. If there are several cracks, holes can be drilled in a staggered manner at 500 to 750mm spacing in both directions covering adequately the area proposed to be grouted. Holes spacing can be altered as per site conditions with approval of the Engineer.
- ii) G.I. pipe pieces (12 to 20mm dia x 200mm) with one end threaded are fixed in the holes with rich cement mortar.
- iii) All the cracks and annular space around G.I. pipes are sealed with rich cement, mortar. All the cracks are cut open to a 'V' shaped groove, cleaned & sealed with rich cement mortar.
- iv) All the Grout holes should be sluiced with water using the same equipment a day before grouting as per following sequence; so as to saturate the masonry.

All holes (Annexure 2/7) are first plugged with proper wooden plugs. The bottom most plug (1) and the two adjacent

plugs (2 and 9) are removed and water injected in the bottom most hole (1) under pressure. When the clear water comes out through the adjacent holes (2 and 9) the injection of water is stopped and the plugs in the bottom most hole and the one immediately above (1 and 9) are restored. The process is repeated with hole numbers 2, 3 & 8 etc. till all the holes are covered. On the day of grouting all the plugs are removed to drain out excess water and restored before commencing grouting.

- v) The same sequence as described above is adopted for injecting the cement grout also. The grout is kept fully stirred / agitated under pressure throughout the grouting. The grouting is carried out till refusal and / or till grout starts flowing from the adjacent hole. A proper record of the quantity of grout injected into every hole should be maintained.
- vi) After grouting, curing should be done for 14 days.
- vii) Tell tales are provided for checking the effectiveness of grouting.
- viii) Only such quantities of material for preparing grout should be used, as can be used within 15 minutes of its mixing.
- ix) Grouting equipment must be cleaned thoroughly after use.

## **2. Epoxy grouting**

As compared to cement, epoxy is quick setting, has very low shrinkage, excellent adhesion, high strength, low viscosity to penetrate even hair cracks and good resistance to most of the chemicals. However, epoxy grouting, being expensive, should be used only when it is techno economically justified.

a) Composition : The epoxy grout consists of an epoxy resin and a hardener which react chemically when mixed. Epoxy resins are thermosetting and by suitably proportioning of the mix of resin, hardener and thinner (if necessary), the viscosity of the mix can be varied to suit all types of conditions. Grouting of wide cracks require large quantity of grout material. In such cases suitable fillers e.g. dry silicon flour etc. can be added based on manufacturer's recommendations.

b) Specification : Considering the width, depth and extent of cracks and other relevant details, the viscosity of the resin hardener mix, their

proportions, pot life, application procedure etc. should be chosen in consultation with the manufacturers. The shear strength on a specimen of two mild steel plates should not be less than 100 kg/cm<sup>2</sup>. The epoxy mortar should not be susceptible to fire and explosion during injection process and must be stable under varying climatic conditions.

c) Test certificates : The supplier should produce test certificates for Pot life test, strength test and shear test from approved test houses.

d) Equipments required :

- i) Pneumatic or electric hole drilling equipment.
- ii) Pressure injection equipment of standard make with necessary control valves and gauges, etc.
- iii) Air compressor of capacity 3 to 4 cum/min. and pressure of 10 kg/cm<sup>2</sup>.
- iv) Polythene or metal pipe pieces 6-9mm dia.
- v) Polythene/plastic containers for mixing the epoxy formulation.
- vi) A portable generator.

e) Procedure for epoxy grouting (Annexure 2/8)

- i) The area to be grouted should be dry and free from oil, grease, dust and all loose and unsound materials.
- ii) All cracks should be cut open to a 'V' groove about 10mm deep by mechanical or manual means. Loose material should be removed by using compressed air and groove fully sealed using epoxy mortar at least one day in advance.
- iii) Nails are driven into the cracks at 15 cm to 50cm intervals along the crack.
- iv) Holes of 7 - 10 mm dia should be drilled along the cracks and copper or aluminium or polythene pipe pieces of 6 - 9 mm dia fixed as grout nipples around the nails and allowed to rest on them.
- v) Epoxy formulation is injected from the bottom most pipe, keeping all other pipes, except the adjacent ones, blocked by wooden plugs. The injection is done using suitable nozzles connected

to air compressors or by hand operated modified grease guns. Pressure of 3.5 to 7 kg per sq. cm is normally used. As soon as the epoxy comes out from the adjacent open pipes, they are plugged and the pressure increased to the desired level and maintained for 2 to 3 minutes. The injection nozzle is then withdrawn and the hole sealed with epoxy mortar. This operation is repeated for the other pipes also. Any resin that remains or overflows the copper pipe is scraped off with a metal spatula and the surface cleaned with a rag soaked in non-inflammable solvent.

- vi) Due to restriction of pot life, it is advisable to mix only small quantities of epoxy at a time. All proportioning should be by weight and mixing should be thorough.
  - vii) Low viscosity resins may be adopted for thin cracks.
  - viii) A record of materials consumed should be maintained.
- f) Precautions while handling epoxy resins.
- i) Manufacturer's detailed instructions should be followed for safe handling and processing.
  - ii) Direct skin contact should be avoided and hand gloves (rubber) and protective goggles should be used.
  - iii) The grease gun syringe should be washed with acetone immediately after use.

### **3. Shot creting / Guniting**

a) Shotcrete is mortar or concrete conveyed through a hose and pneumatically impinged at high velocity on to the surface to be treated. The force of the jet impinging on the surface compacts the material. Generally a relatively dry mixture is used so that it supports itself without sagging or sloughing even for vertical and overhead applications. This process is also known as Guniting.



b) Shotcrete or gunite is suitable for repairing spalled concrete surface as well as for strengthening weathered stone or brick masonry. For most applications mortar applied by the dry process (guniting) is adequate. With concrete (shotcrete) the wet process is adopted. In both the cases reinforcement in the form of wire 3mm dia, wire fabric or steel bars upto 16mm dia may be used, as necessary.

c) Equipment required (Annexure 2/9)

- i) Guniting machine complying requirements given in IS : 6433.
- ii) Air Compressor with a capacity of 10 cum/per minute and which can develop a pressure of upto 7 kg/cm<sup>2</sup>.
- iii) Placing nozzle with hose.

d) Specification of materials used :

- i) Ordinary Portland cement to IS : 269. (Other special cements can be used for special applications requiring higher strength or early setting)
- ii) Sand conforming to IS : 383 and graded evenly from fine to coarse as per Zone II and III with a nominal max. size of 6mm.
- iii) Coarse aggregate, when used, should conform to IS : 383, with a maximum nominal size of 10 to 12.5 mm.
- iv) water conforming to IS : 456.
- v) Admixture as recommended.
- vi) Reinforcing bars, as per IS : 432 or welded wire fabric conforming to IS : 1566 may be used as required.
- vii) Water cement ratio 0.35 to 0.50 by weight.

e) Preparation of surface : All weathered or deteriorated material should be removed until the surface exposed is sound and properly shaped to receive the gunite (Shotcrete). The surface should be cleaned of all loose and foreign materials with an air/water jet. If the joint mortar is weak, the joint should be raked to about 10mm depth and all loose, dry mortar scraped out. Exposed reinforcement should be cleaned free of rust, scale etc. and given a coat of neat cement or any other anti-corrosive material. Porous surface should be kept damp for several hours before guniting.

f) Form work : The forms where required shall be plywood or other suitable material set true to line and dimension. They should be adequately braced and constructed so as to permit the escape of air and rebound during the guniting operation (particularly in the case of thick members).

g) Reinforcement : Depending on the thickness and nature of the work; reinforcement may consist of either round bars, or welded wire fabric 3mm diameter. Sufficient clearance should be provided around the reinforcement. The minimum clearance between the reinforcement and form or other back up material may vary between 12mm for the mortar mix and wire fabric reinforcement to 50mm for the concrete mix and 16mm dia reinforcing bars. However, the minimum cover for reinforcement shall be as per IS : 456. The minimum wire mesh spacing should be 50 mm by 50 mm. Clear spacing between bars should be atleast 65 mm.

For repair work, the reinforcement should be fixed to existing masonry by wiring to nails driven into the masonry and rigidly secured.

h) Preparing the gunite : The cement and sand in specified proportion are premixed and placed in the feeding chamber; the same is then fed into the working chamber through a cone valve controlled from outside. The mixture, after passing through an agitator is then carried in suspension by compressed air through the delivery hose to the nozzle. The mixing time shall not be less than one minute. As the material passes through the nozzle body, it is hydrated with water introduced in the form of a fine needle spray. The amount of water added is adjusted so that the in-place gunite/shotcrete is adequately compacted and it neither sags nor shows excessive rebound. The mix used generally ranges from 1:3 to 1:4.5 and moisture content of the mixture before placing in the machine should be within 3 to 6%.

i) Uniform air pressure is maintained at the nozzle outlet. For lengths of hose upto 30m, the air pressure is 3kg/cm<sup>2</sup> or more. For longer lengths the pressure is increased by 0.35kg/cm<sup>2</sup> for each additional 15m of hose and by 0.35kg/cm<sup>2</sup> for each staging of 7.5m that the nozzle is raised above the gun.

j) Placing : The total thickness of gunite required should be built up in a number of layers with an interval of about 4 hours. Each layer is built up by making several passes or loops of the nozzle over the working area. The distance of the nozzle from the work, usually between 0.5 and 1.5m, should be such as to give the best results. Particular care should be taken when gunning through and encasing reinforcing bars. (For walls, columns and beams, the application should begin at the bottom). In guniting slabs, the nozzle should be held at a slight angle so that the rebound is blown on to the completed portion.

k) Rebound : The rebound is mortar or concrete which bounces off the surface during the application. Rebound should not be worked back into the construction and should be rejected.

l) Before laying additional layer, the first layer should be allowed to take its initial set. Then all laitance, loose material and rebound should be removed. The surface should be tested with a hammer for drummy areas which should be carefully cut out and replaced with the succeeding layer.

m) Curing : The surfaces should be kept continuously wet for at least 7 days.

n) Shotcreting by the wet process requires special equipment and can be used for building up thick layer. For further details reference can be made to IS : 9012 "Recommended Practice for shotcreting".

## **PART D**

### **MAINTENANCE OF SUPER STRUCTURE - REINFORCED CEMENT CONCRETE AND PRESTRESSED CONCRETE BRIDGES**

#### **210. Periodical maintenance**

1. The areas around bearings shall be kept free of ballast, debris, dust, oil / grease etc.

2. Drainage system shall be thoroughly cleaned and repaired as necessary before the onset of monsoon.

3. Protective surface coat, where provided, shall be maintained.

4. The superstructure and bearings shall be maintained as per the design requirements and any deficiencies/defects noticed during inspection shall be attended to.

5. Water on deck bridges should not be allowed to stagnate or retained in the ballast. Cleaning of ballast and drainage arrangements to be ensured annually before monsoons.

### **211. Common defects and repair/strengthening techniques**

1. For the repairs of following type of defects, techniques described in para 209 may be suitably adopted.

- a) Signs of honeycombing and/or hollow spots in concrete components and spalling.
- b) Dormant cracks
- c) Active cracks whose cause of cracking has been determined and remedial action has been taken.

2. Other Strengthening techniques :

a) External prestressing of concrete girders both in longitudinal and vertical directions can be successfully adopted as a strengthening measure. Vertical prestressing may be adopted to prevent separation of deck slabs which are generally cast in situ over precast girders. Longitudinal prestressing may be adopted to strengthen the girder and to increase its flexural strength. Longitudinal prestressing may be resorted to in cases where girders are required to carry increased load or the existing prestressed cables have deteriorated.

b) Established techniques such as external bonding of steel plates etc. can also be adopted for which specialist literature may be referred.

## **PART E**

### **MAINTENANCE OF SUPER STRUCTURE - STEEL GIRDERS**

#### **212. Loss of camber in steel girders**

1. Steel triangulated (open web) girders are provided with camber to compensate for deflection under load. Out of the total design camber, the part corresponding to dead load is called dead load camber. The balance is called live load camber which should be available as visible and measurable camber in the girder when not carrying load.

2. Loss of camber can be mainly attributed to :

- a) Overstressing of members beyond the elastic limit
- b) Overstressing of joint rivets
- c) Loose rivets

3. Rectification measures :

a) If it is established that the loss of camber is due to 2 (a) above which can be due to running of heavier loads or heavy loss of section of bridge member due to corrosion, action should be taken to strengthen the girder with proper camber or replace the girder.

b) In case the loss of camber is due to overstressing of joint rivets the joint should be redesigned and rivets and gusset plates replaced as required after providing the designed camber.

c) All the loose rivets should be replaced by sound rivets and proper camber provided.

### **213. Cracks in steel works**

1. Whenever a crack is detected in the steel work, its cause should be established and further propagation, if any, monitored. As a first remedial step, a small hole of 7mm diameter should be drilled at the extremities of the crack to prevent its further propagation.

2. As a long term solution the cracked member may be strengthened by cover plate (s), adequately rivetted. If this is not feasible, the defective member may have to be taken out and repaired/replaced.

### **214. Strengthening of weak girders**

1. Such cases generally occur when loads heavier than those considered for design have to be carried. It is likely that the entire girder may not need replacement, but only certain components may need strengthening/replacement. All the strengthening works require, very careful check of design, and planning for execution.

2. The common methods of strengthening are :

- a) Replacement of weak rivets by larger diameter rivets.
- b) Replacement/strengthening of floor system, namely, stringers and cross girders.

c) Addition of flange/web plates to plate girders : For this removal of the girder from the road and replacement by a relieving girder may be necessary.

d) Strengthening of weak members of an open web girder : As the work is of complicated nature, panel points will have to be jacked upon trestles to designed camber levels, to eliminate dead load stresses and weaker members replaced with stronger ones by accurately match marking and match drilling of rivet holes.

3. If work of an extensive and repetitive nature is involved, it is preferable to take out one member (such as cross girder, rail bearer etc.) at a time and replace it by a spare member specially manufactured for the purpose. The member thus taken out can be satisfactorily repaired outside and used to replace the next defective member and so on.

### **215. Replacement of loose rivets**

#### 1. General :

- i) Slight slackness of rivet does not cause loss of rivet strength.
- ii) Renewal of slack rivets should be done only when the slack rivets are in groups or are bunched up. Individual scattered slack rivets need not be touched.
- iii) Rivet is to be considered finger loose when the looseness can be felt by mere touch, without tapping. Rivets should be considered hammer loose, when the looseness can be felt only with the aid of a hand hammer.
- iv) All rivet renewals in a bridge girder shall be done only with pneumatic rivetting. In exceptional cases and at locations where pneumatic tools cannot be employed, hand rivetting may be resorted to.

2. The following points should be kept in mind while carrying out the rivetting work.

a) In pneumatic rivetting, the driving of the rivet, filling of the hole and formations of the head should be done by snap mounted pneumatic hammer by delivering quick hard blows on practically white

hot rivet. The rivet head should be held tightly against the member through a pneumatically hand pressed dolly.

b) The rivet shank should be about 1.5mm less than the diameter of the drilled hole.

c) The length of the rivet shank may be worked out by the formula  
 $L = G + 1.5D + 1\text{mm}$  for every 4mm of grip or part there of for snap head rivet.

$L = G + 0.5D + 1\text{mm}$  for every 4mm of grip or part thereof for counter sunk rivet.

where

L = length of rivet shank

G = length of grip in mm

D = diameter of rivet in mm

d) While rivetting a loose joint, not more than 10% rivets should be cut at a time. Besides, each rivet should be replaced immediately after cutting, with a turned bolt of adequate diameter and length and then only the next rivet should be cut. In 50% of the holes cut parallel drifts of correct diameter may be used; using turned bolts for the other 50%.

e) It is preferable to drill a rivet out than to use a rivet burster as the latter cuts the rivet head in shear, imparting very heavy shock to the adjoining group of rivets.

f) In a joint where only a few rivets are loose, the adjoining rivets are also rendered loose while bursting the loose rivets. In any case, after the loose rivets in a joint are replaced, it is very necessary that all the rivets in the assembly are rechecked for tightness.

g) At locations where replacing rivets is difficult, turned bolts of appropriate diameter and length may be used.

h) The rivet must be heated almost to a white heat and to a point when sparks are just beginning to fly off. The whole rivet must be brought to the same heat. The rivet should be driven and the snap removed within 20 seconds of the rivet leaving the fire.



j) The rivet must be driven straight, while hot, keeping the hammer coaxial. The rivetter must have his staging at a height which enables him to put the whole weight of his body behind the hammer. This prevents it from bouncing.

k) Rivets conforming to IRS specifications only should be used.

l) Adequate air pressure of 5.6 to 7 kg/cm<sup>2</sup> should be ensured for opening of the tools.

m) In the case of long bridges, the air compressor may be centrally located at a suitable trolley refuge, with main pipe line running in both directions with suitable tapplings.

3. The following guide-lines may be followed for replacement of loose rivets in plate girders. Renewal of slack rivets should be taken up for :

- i) All rivets which are hand loose or which have lost 50% of their head by corrosion.
- ii) All hammer loose rivets where corrosion has set in between the head and the plate.
- iii) In end stiffeners when the percentage of hammer loose rivets is >30%
- iv) In flange splices when the number of hammer and hand loose rivets is 30% or more of the total rivets on any side of the splice location, all the rivets should be renewed.
- v) All hammer loose rivets at main angle to web connection upto 1/12 span from either support of the girder.
- vi) When loose rivets in end connections of lateral and cross bracings of plate girder spans require renewal, all the rivets in the end connections should be renewed.
- vii) Subject to the conditions in (i) and (ii) above, rivets, though hammer loose, need not be renewed under the following locations :
  - a) In the lap or butt joints of trough flooring,
  - b) Through angle or tee intermediate stiffeners on girders,
  - c) At main angle to web connections except those covered in (v),
  - d) In flange plates,
  - e) In web splices.

**216. Corrosion and its prevention**

1. Corrosion is deterioration of metal due to its interaction with the corroding environment.

2. When steel is exposed to the atmosphere, it combines chemically with the oxygen to form oxides. This is generally described, as rust. In addition, steel gets corroded by other harmful chemicals to which it may be exposed, such as acidic fumes and salt in sea spray etc.

3. Corrosion may take place in either of the following forms :

i) Uniformly over large areas, referred to as "Uniform corrosion" or limited over a local area, referred to as "local corrosion".

ii) Restricted to an extremely minute area, referred to as "pitting".

4. Prevention of corrosion : Corrosion may be prevented by any one of the following means :

a) Protective coatings by painting (refer para 217).

b) Metallising - a form of protection by spraying a metal either zinc or Aluminium (refer para 218).

c) Use of epoxy based paints.

**217. Protective Coatings by painting**

1. Correct surface preparation of the steel to receive the paint:

This is the single most important factor in ensuring good performance, as the presence of rust under the paint film can cause its failure. Removal of rust, oil, grease and dirt is also necessary to ensure adequate adhesion of paint film to the surface.

a) The minimum requirements of a surface prepared for painting are:

i) It should be clean, dry and free from contaminants.

ii) It should be rough enough to ensure adhesion of the paint film.

However, it should not be so rough that the film cannot cover the surface peaks.

b) Any one or a combination of the following methods (i to iv) for surface preparation may be used, where rust has appeared in many places and existing primary coat of paint has developed cracks, blistering, peeling, brittleness etc.

i) Manual hand cleaning : The cleaning of surface is done with the use of emery paper, wire brushes, scrapers, etc. This is adopted for spot cleaning during normal maintenance to remove rust, scale or old coatings.

ii) Cleaning with power driven tools : Oil and grease are first removed. Heavy scale and rust are then removed by hand tools. Residual rust and mill scales are removed by hammer or rotary action of hand held power driven tools.

iii) Blast cleaning (sand or grit blasting) : It consists of cleaning the surface with the help of high velocity impact of abrasives (sand or grit) against the surface. It removes rust, mill scale (oxidisation) and old paints along with some of the base metals and creates a base for good adhesion. It is the most effective method of surface preparation.

iv) Flame cleaning : The process consists of localised application of an oxy-acetylene flame on the steel surface. After the application of the flame the rust can be removed by wire brushes. Flame cleaning should not be done on plates with thickness 10mm or less as it may lead to permanent distortion of such plates.

v) In the case of maintenance painting where only the finishing coat of paint shows signs of deterioration and the primary coat of paint is sufficiently in good condition adhering to the metal firmly and there are no signs of rust, the surface should be washed with lukewarm water containing 1 to 2% detergent to remove salt deposits and grime. After this, the surface is to be dried, lightly wire brushed and sand papered. On this prepared surface only the finishing coat of paint should be applied.

vi) Temporary coatings : If, for any reason, painting can not immediately follow surface preparation, corrosion can be prevented for a short time by means of temporary coating of Linseed oil applied uniformly and thinly (one third litre on 10m<sup>2</sup> area will be sufficient). Modern prefabrication primers which are easier to apply and give better protection are also available.

## 2. Choice of suitable paints :

The following system of paints may be adopted for painting of Bridge girders :

a) In areas where there is no severe corrosion

i) Priming coat : One heavy coat of ready-mixed paint red lead priming to IS : 102

**OR**

One coat of ready mixed paint zinc chromate priming to IS : 104, followed by one coat of ready mixed paint red oxide zinc chrome priming paint to IS : 2074.

**OR**

Two coats of zinc chromate red oxide primer to IRS - P - 31

ii) Finishing coat :

Two cover coats of red oxide paint to IS : 123 or any other approved paint applied over the primer coats.

b) In areas where corrosion is SEVERE

i) Priming Coat :

Two coats of ready mixed paint red lead Priming to IS : 102

**OR**

One coat of ready mixed paint zinc chromate priming to IS : 104 followed by one coat of zinc chrome - red oxide priming to IS : 2074

ii) Finishing coat :

Two coats of aluminium paint to IS : 2339.

c) In case where the priming coat is in good condition the steel work is painted with two coats of ready mixed red oxide paint to IS : 123 or paint aluminium to IS : 2339 depending on the severity of corrosion.

3. Conditions for obtaining good painting :

a) Painting should be done in dry and reasonably warm conditions. The relative humidity should not be above 90%.

b) Dew frequently condenses on a structure during night and hence painting at night and in the early hours of morning should be avoided.

c) Painting should be avoided during rainy season and in adverse weather conditions (dust storm, mist, fog, etc.)

d) Control of paint film thickness :

- i) It is desirable to control and check the thickness of paint applied to a structure. The wet film thickness can be monitored by means of the wet film gauges from the rate of paint consumption at intervals during application. To provide a recognizable surface appearance and assist in rapid visual inspection during the course of the work, a reference patch or patches of required thickness should be painted on the structure. Measurements of Dry Film Thickness (DFT) should be done systematically over the whole structure and results assessed. Attention should be paid not only to the average DFT but also to uniformity of application. The normal thickness as also the minimum thickness of the dry film should be specified and ensured during execution. It would be desirable to specify the number of measurements to be made (at least one reading for each sq. m. of area painted will be reasonable).

- ii) Measurement of dry film thickness (DFT) : The following instruments may be used to measure the DFT.

Electronic coating thickness gauge

Elcometer (Magnetic thickness gauge) Dial Type,

Surface profile gauge (dial type)

Most of the instruments work on magnetic or electro magnetic principles and indicate the total thickness of the paint coat including the primary readings. Readings must, therefore, be taken after surface preparation and after completion of painting to arrive at the DFT.

4. Precautions to be taken during Bridge painting :

- a) Paints from approved manufacturers only should be used.
- b) Special care should be taken to shift sleepers on girders or rail bearers to clean the seating very thoroughly before applying the paint.
- c) Paint should be mixed in small quantities sufficient to be consumed within 1 hour in the case of red lead paint and 5 days in the case of red oxide paint.

d) While painting with red oxide paint, a little quantity of lamp black shall be added to the paint while doing the first coat to distinguish it from the second coat. Similarly, in the case of aluminium paint a little blue paint can be added, instead of lamp Black for 1st coat.

e) Paints should be used within the prescribed shelf life from the date of manufacture. The quantity of paint procured should be such that it is fully utilised before the period prescribed for its use.

The shelf life of various paints used in the Railways are as follows:

- |      |                                        |                  |
|------|----------------------------------------|------------------|
| i)   | Paint Red Lead Ready Mixed (IS : 102)  | 4 months         |
| ii)  | Paint Red Oxide Ready mixed (IS : 123) | 1 year           |
| iii) | Paint aluminium :                      |                  |
|      | When paste and oil are not mixed,      | 1 year           |
|      | When paste and oil are mixed           | 4 months         |
| iv)  | Oil linseed boiled                     | 2 years          |
| v)   | Red lead dry paint                     | (No time limit.) |

f) Brush shall not be less than 5cm in width and should have good flexible bristles. A new brush before use should be soaked in raw linseed oil for atleast 24 hours. The brushes shall be cleaned in linseed oil at the end of each day's work.

g) Dust settled after scraping shall be cleaned before applying paint.

h) When the paint is applied by brush, the brush shall be held at 45° to the surface and paint applied with several light vertical / lateral strokes turning the brush frequently and transferring the paint and covering the whole surface. After this, the brush shall be used crosswise for complete coverage and finally finished with vertical / lateral strokes to achieve uniform and even surface.

j) Rags, waste cotton, cloth or similar articles should not be used for applying paint.

k) The coat of paint applied shall be such that the prescribed dry film thickness is achieved by actual trial for the particular brand of paint. The applied coat of paint shall be uniform and free from brush marks, sags, blemishes, scattering, crawling, uneven thickness, holes,

lap marks, lifting, peeling, staining, cracking, checking, scaling, holidays and allegatoring.

l) Each coat of paint shall be left to dry till it sufficiently hardens before the subsequent coat is applied. The drying time shall not be less than 3 days in the case of Red lead paint.

m) The entire contents of a paint drum should be mixed thoroughly either by pouring a number of times or by mechanical mixing to get uniform consistency. The paint should not be allowed to settle down during painting by frequent stirring or mixing.

Driers such as spirit or turpentine should not be used. Mixing of kerosene oil is strictly prohibited.

n) The maximum time lag between successive operations as indicated below shall not be exceeded.

- i) Between surface preparation and the application of primer coat -24 hours
- ii) Between surface preparation and first finishing coat in the case of patch painting - 48 hours
- iii) Between the primer coat and the 1st finishing coat - 7 days
- iv) Between the 1st finishing coat and the 2nd finishing coat - 7 days

#### 5. Periodical through painting :

The entire steel work of a girder should be painted at regular intervals which may vary from six years in arid zones to one year in highly corrosive areas. The chief Engineer shall prescribe the periodicity of painting. Floor system of girders etc. where corrosion is heavy, may require painting more frequently. Their periodicity should be as specified by the chief Engineer.

#### 6. Patch painting :

a) When small areas of paint show pronounced deterioration, which require immediate remedy, it is not desirable to wait for the girder or the member as a whole becoming due for periodic painting. The affected areas must be patch painted. The usual locations which may require patch painting are :

- i) Some parts of the girders like the upper surface of top chord members,
- ii) The inside surface of bottom chord members,
- iii) top flanges of plate girders,
- iv) Deck systems of through or semi through span etc.

b) The surfaces requiring patch painting should be scraped down to bare metal and the painting techniques followed on similar lines, as prescribed for painting to cases where the existing paint coats have deteriorated fully. There may be cases where the top coat only has failed, in which case the affected top coat should be wire brushed thoroughly and required number of finishing coats applied.

### **218. Metallising & Epoxy based Paints**

For locations where girders are exposed to corrosive environment i.e. flooring system of open web girders in all cases, girders in industrial, suburban or coastal areas etc., protective coating by way of metallising or by painting with epoxy based paints may be applied :

#### **1. Metallising**

In metallised protection base metal like zinc or aluminium is lost by the atmospheric action, while the base metal (steel) remains unaffected. Zinc or aluminium can be sprayed on the surface prepared by grit/sand blasting for giving such protection, known as metallising.

##### i) Surface preparation :

a) The surface of steel shall be free from oil, grease, bituminous materials or other foreign matter, and shall provide an adequate key for the sprayed metallic coating. This may be achieved by flame cleaning or by sand blasting. However, the abrasive once used for cleaning heavily contaminated surface should not be reused even though rescreened.

b) Final cleaning is done by abrasives i.e. Chilled iron grit G.24, as defined in BS : 2451 or Washed salt free angular silica sand of mesh size 12 to 30 with a minimum of 40% retained on a 20 mesh screen, as per following details :

Air Pressures : Not less than 2.109 kg per sq.cm.



Nozzle position : At right angles to and approximately  
22.5 cm. from the surface

Nozzle dia : Not exceeding 12 mm

c) The final surface roughness achieved shall be comparable to roughness with a reference surface produced in accordance with Appendix A of IS : 5909 and shall provide an adequate key for subsequently sprayed metal.

ii) Metallising process :

a) The sprayed coating shall be applied as soon as possible after surface preparation. The wire method shall be used for this purpose, the diameter of the wire being 3 mm or 5 mm. The composition of the aluminium to be sprayed shall be preferably in accordance with BS : 1475, material 1-B (99.5%) aluminium otherwise as per IS : 739.

b) Clean dry air at a pressure of not less than 4.218 kg per sq.cm. shall be used. The minimum thickness of metal coating applied shall be 115 microns and average thickness 150 microns.

c) The specified thickness of coating shall be applied in multiple layers, not less than two. The surface after spraying shall be free from uncoated parts or lumps of loosely spattered metal.

d) At least one layer of the coating must be applied within 4 hours of blasting and the surface must be finished to the specified thickness within 8 hours of blasting.

iii) Inspection :

a) The metal coating shall be checked for thickness by an approved magnetic thickness measuring gauge.

b) The calibration of the gauge should be checked against a standard of similar thickness within an accuracy of 10 per cent.

iv) Finishing coat of painting :

a) After the metallising, any oil, grease etc. should be removed by thorough wash with a suitable thinner and allowed to dry for 15 minutes. The painting may be applied by brush or by spray. The first coat shall be wash primer to SSPCPT - 3 53T or Etch primer to IS : 5666.

b) The second coat shall be zinc chromate primer to IS : 104. The

zinc chrome should conform to type 2 of IS : 51. The 3rd and 4th coats shall be aluminium paint to IS : 2339.

v) Maintenance painting of metallised girders :

a) The need for periodical repainting and the method to be followed will depend on the condition of the existing paint. In most cases complete removal of existing paint film may not be necessary.

b) The surface is cleaned of all oil, dirt and other foreign material. If the existing top coats of aluminium paint are found to be in good condition, it will be sufficient to apply one additional coat of the same paint, once in 5 years or at such closer intervals as specified.

c) However, if the existing paint is found flaked or damaged, it should be removed completely by wire brushing without the use of scrapers or chipping tools. In case the original coat of zinc chromate primer is also damaged in patches, such patches should be painted with fresh zinc chromate primer before applying the finishing coat of aluminium.

d) In the event of any localised damage to the metallised coating of aluminium, as evidenced by traces of rust, the affected portion should be thoroughly cleaned of all rust before the priming and top coats of paints are applied. Rust streaks caused by droppings from the track or by contact with hook bolt lips should not be mistaken for corrosion.

vi) Precautions to be taken while inspecting metallised girders :

The use of testing hammers for rivet testing, or any other operation shall not be resorted to since these can damage the metallised coating. Any looseness of the rivets in bracings etc. may be detected from visible signs such as the appearance of rust under the rivet head.

## **2. Epoxy based Paints**

i) Surface Preparation :

a) Remove oil/grease from the metal surface by using petroleum hydrocarbon solvent to IS : 1745.

b) Prepare the surface by sand or grit blasting to Sa 2½ to IS : 9954 i.e. near white metallic surface.

## ii) Painting :

## a) Primer coat :

Apply by brush / airless spray two coats of epoxy zinc phosphate primer to RDSO specification No. M & C /PCN-102/86 to 60 microns minimum dry film thickness (DFT) giving sufficient time gap between two coats to enable first coat of primer to hard dry.

## b) Intermediate coat :

Apply by brush/airless spray-one coat of epoxy micaceous iron oxide to RDSO specification No. M & C /PCN-103/86 to 100 microns minimum DFT and allow it to hard dry.

## c) Finishing coat :

Apply by brush/airless spray two coats of polyurethane aluminium finishing to RDSO Specification No. M & C /PCN-110/88 for coastal locations or polyurethane red oxide (red oxide to ISC 446 as per IS : 5) to RDSO Specification No. M&C/PCN-109/88 for other locations to 40 microns minimum DFT giving sufficient time gap between two coats to enable the first coat to hard dry. The finishing coats to be applied in shop and touched after erection, if necessary.

**219. Maintenance of welded girders**

## 1. Propagation of cracks in welded girders :

a) Fatigue cracks develop in steel girders during service due to repeated loading and their magnitude depends on the magnitude of stress variation, frequency of stress application, type of connections, quality of fabrication and age of steel. Welds are more sensitive to the repeated stresses and once crack starts it can grow fast and seriously reduce the strength of the member.

b) The location, length, orientation of cracks etc. should be marked distinctly with paint for easy identification, reference and subsequent monitoring of crack propagation.

c) Each crack should be examined in detail with magnifying glass. Non destructive inspection methods like dye penetration test, ultrasonic test etc. as found necessary may be adopted.

d) If identical locations exist elsewhere in the girder, they should also be closely examined.

e) Significance and severity of crack should be studied on the load carrying capacity of the girder.

f) Repair or retrofit scheme should be prepared after fully investigating the cause of the crack.

2. Repair of cracks :

a) The method of repair of crack should be decided based on the location and severity of the crack.

b) If the crack is propagating in a direction perpendicular to the stress in member, holes 20 or 22 mm dia may be drilled at crack ends to arrest the crack propagation. The edge of holes should be placed at visible ends of the crack. After holes are drilled it should be checked that crack tips have been removed and turned bolts of 20 or 22 mm dia as the case may be should be provided in the holes and fully tightened. Any reduction in strength of girder due to the crack and drill of holes should be given due consideration.

c) Permanent measures may consist of the cracked member being retrofitted with rivetted or bolted splice or where feasible the entire member may be replaced.

d) Field welding should not be undertaken for repair of cracks, unless they are of a minor significance. The repair should be done by trained welders and the repaired portions examined visually and/or by non destructive testing.

## PART F

### MAINTENANCE OF COMPOSITE GIRDERS

#### **220. The following action should be taken for maintenance of composite girders**

a) The welded steel portion of the composite girder should be maintained as per the procedure detailed in paras 217, 218 and 219.

b) If separation of the concrete deck slab from the steel girder is noticed, the location and length should be marked distinctly with paint for easy identification. Repair and retrofit scheme should be prepared after fully investigating the cause of the problem. Epoxy grouting may

be done to bind the deck slab and the girder where the defect is noticed and the girder should be kept under close observation. If the epoxy grouting is not found effective, vertical prestressing or strapping may be necessary for which holes should be drilled in the deck slab near the girder in the affected location and vertical prestressing/strapping provided.

c) The drainage system of the deck slab should be thoroughly cleaned and repaired as necessary before the on set of monsoon.

d) Wearing coat where provided, should be maintained.

e) Any deficiencies / defects noticed during inspection should be attended to promptly.

## **PART G**

### **MAINTENANCE OF BED BLOCKS**

#### **221. The various defects and their remedies are outlined below**

a) Improper seating of bearings: Due to uneven contact area, gaps exist between bed block and base plate. Cracks even develop due to improper seating of bearing.

b) Shaken bed blocks : The bed blocks start loosening if they are of isolated type and a gap develops between surface of bed blocks and surrounding masonry. In such cases the remedy is grouting with cement mortar ensuring adequate curing and allowing sufficient time for the mortar to set. If bed block is shaken, the same should be inspected under traffic for visible movements and only then it should be confirmed as a shaken bed block. Action may be taken to either encase the bed block or replace it by through bed blocks. Precast bed blocks can be cast and bonded with epoxy resin mortar. (For details para 514.3 may be referred.

c) Cracking and crushing of masonry : In these cases the most effective remedy would be to replace the bed blocks with an insitu, RCC, through bed block and attending to the cracks in the substructure.

## PART H

### MAINTENANCE OF BEARINGS

#### 222. Bearings

1. Types of bearings : The bearing transfers the forces coming from the superstructure to the substructure. It also allows for necessary movements in the superstructure which are caused by temperature variations. The following types of bearings are generally used.

a) Sliding bearing permitting rotation and translation (Annexure 2/10)

b) Rocker and Roller bearing (Annexure 2/11), with or without oil bath, permitting rotation and translation respectively. Oil bath bearings are generally provided for new girders of spans above 76.2m and for other open web girders, whether new or existing, in case it is considered difficult to lift the girders for periodic greasing.

c) Elastomeric bearings (Annexure 2/12) permitting rotation and translation

d) P.T.F.E. Bearings (Annexure 2/12) permitting rotation and translation

2. Maintenance of sliding and roller & rocker bearings :

a) All bearings should be generally cleaned and greased once in three years.

b) In the case of sliding bearings, the girder is lifted a little over 6mm and the bearing surfaces cleaned with kerosene oil and a mixture of black oil. Grease and graphite in a working proportion may be applied on bearing surfaces and the girder lowered. Jacking beams may be inserted wherever necessary.

c) The roller and rockers are lifted from their position (by adequate slinging). The bearings are scraped, polished with zero grade sand paper and grease graphite in sufficient quantity applied evenly over the bearings, rockers and rollers before the bearings are lowered. The knuckle pins of both the free and fixed and should also be greased. While lifting fixed ends, the space between girders (in case of piers), or between the girder and the ballast wall (in case of abutment) at the free ends should be jammed with wedges to prevent longitudinal movement of the girders.

d) Phosphor bronze bearings need not be greased as they are corrosion resistant and retain the smooth surface.

e) The tooth bar of the roller assembly should be placed vertically at mean temperature. It will be better to indicate in the completion drawings of bridge stress sheet, the maximum expansion, and range of temperature for which the bearing is designed, so that the slant at the time of greasing can be decided depending on the temperature obtaining at the time of greasing.

f) In the case of roller bearings with oil bath, dust covers should invariably be provided to keep the oil free from dirt. Wherever oil bath bearings are provided, inspection of the bearings, after removal of the casings to the extent necessary, should be carried out at least once in 5 years. Checking of oil level, draining out as necessary to detect and remove any water collected at the bottom and replenishing the oil, should be done annually.

### 3. Elastomeric bearings :

a) Elastomeric bearings are made of natural or synthetic rubber of shore hardness of approximately 50 to 70. They are very stiff in resisting volume change but are very flexible when subjected to shear or pure uni-axial tension. They are generally reinforced with steel plates in alternate layers to reduce bulging. When used with a steel or concrete girder these permit moderate longitudinal movements and small rotations at the ends.

b) These bearings require periodic cleaning. They may require replacement in service depending on the condition and usage.

### 4. Teflon or P.T.F.E. bearings :

a) The coefficient of friction between steel and PTFE is quite low. The mating surface which forms the upper component of the bearing is stainless steel with good surface finish. The PTFE can be unfilled or filled with glass fibre or other reinforcing material. Its bonding property is very poor. Hence it is preferable to locate the PTFE by confinement and fitting of half the PTFE thickness in recess in a metallic matrix.

b) These are used either to provide rotation by sliding over cylindrical or spherical surfaces or to provide horizontal sliding movement over flat surface or a combination of both. Where there are large displacements accompanied with relatively small loadings, as in

case of centrifugal loads, wind loads or seismic loads, PTFE sliding bearings are utilised.

c) These bearings also require periodic cleaning of the bearing surface.

The interface should be protected from dust. Lubricating the mating surface by silicon grease reduces the coefficient of friction and is desirable.

## **PART I**

### **GENERAL PRECAUTIONS**

#### **223. Precautions while carrying out maintenance works on bridges**

1. For such works, as testing and changing rivets and painting, the Inspector incharge will arrange for look-out men equipped with hand signal flags to be stationed on both sides and for the issue of caution orders to drivers.

2. The Inspector incharge of works must personally satisfy himself that no staging or plant, infringes standard moving dimensions. If this is not possible, the work should be done under block protection.

3. In the case of through bridges or road over bridges on electrified sections, work near the conductors carrying traction current should be done after obtaining traffic and power blocks and under responsible supervision.

4. Where a maintenance or repair operation affects track, such work must invariably be done in consultation with and in the presence of the Permanent Way Inspector.

**□□□**



## CHAPTER - III

### INVESTIGATION AND SURVEY FOR CONSTRUCTION OF BRIDGES

#### **301. Investigation for Minor Bridges**

1. Minor bridges are generally provided on local drainage crossings, field channels and at canal crossings.
2. Pipes are normally proposed where sufficient cushion below the sleeper is available.
3. Where a skew crossing is unavoidable, it is advisable to restrict the skew to  $30^{\circ}$ .
4. The investigation should cover the particulars of catchment area, the soil characteristics, the anticipated flood level and other relevant hydraulic particulars.

#### **302. Investigation for Major Bridges**

The investigation is mostly confined to one particular site and should cover the following aspects:-

- a) Topographical details.
- b) Catchment area with its characteristics from the Survey of India maps.
- c) Hydrological particulars such as low water level, high flood level, discharge data, flood velocity and surface slope from local gauging stations of irrigation and flood control departments and local enquiries.
- d) Geo-technical investigations to get the soil particulars as necessary, for the design of foundations.
- e) Seismology of the area wherever necessary.
- f) Navigational requirements from concerned authorities to determine the clearance.
- g) Construction resources like labour, materials, accommodation, water and power, transport and communication infrastructure, etc. and
- h) Important details of close by bridges across the same river or stream.

**303. Investigation for Important Bridges**

1. Investigation for important bridges may be carried out in three stages viz.

- a) Technical feasibility study (reconnaissance survey)
  - b) Techno-economic feasibility study (preliminary engineering survey)
- and
- c) Detailed survey and project report stage (final location survey)

2. The reconnaissance stage generally covers the study of maps and a few visits to the possible sites and aerial reconnaissance, as necessary. The remaining two stages of investigations should cover the aspects mentioned in the para 302.

3. In case of the meandering course in alluvial and quasi alluvial rivers and rivers having tortuous flows in submontane and mountainous regions, number of alternative sites may be available for locating a bridge. Investigations as detailed in para 302 may be carried out for each one of the alternative sites.

**304. Techno economic feasibility study**

Only a few preliminary drawings and estimates need accompany the techno-economic feasibility report which however should bring out in full detail the comparative merits and demerits of the various alternative sites. The report should bring out the salient features of the bridge, its estimated cost and cost benefit ratio. For this purpose, the approximate waterway may be based on discharge calculated using "Regional flood frequency approach" developed by R.D.S.O. for various subzones or any other similar approach.

**305. Survey of Rivers in connection with the location of an important bridge**

1. Survey of river: The river should be surveyed for a distance of 8 kms. upstream and 2 kms. downstream of the location of the bridge, all spill-channels up-stream being shown on the plan. These distances of 8 and 2 kms. are to be taken as measured at right angles to the center line of the Railway and not along the course of the river.

2. Cross section of the river bed should be taken at suitable points and positions marked on the survey plan. The level of the highest known flood and ordinary low water should be noted on each cross section. The average slope of the river bed is to be determined from a point about 2 kms. upstream of the Railway crossing to a point 2 kms. downstream of the same. In case there are sharp changes in the bed slopes, the local bed slope should be determined over a shorter length.

3. High flood levels: Reliable information of high flood levels should be obtained and noted. This information is required for deciding the formation level.

4. Diversion of rivers: Should it be considered desirable to divert the course of any river or stream, the best method of doing so should be examined, the necessary surveys and sections made and the diversion shown on the survey plan.

5. Protection works: Protection works required to prevent encroachment by rivers or to mitigate the effect of bursting of tanks or scour in the vicinity of the railway line should be carefully considered and the position and the extent of such works surveyed and determined. High flood marks of the spill water should be carefully located and recorded on the plans and sections.

### **306. Hydrological Investigations**

1. Hydrological investigations to the extent necessary depending on the type and importance of the bridge shall be carried out. The following data should be collected:-

- a) Area of the catchment.
- b) Shape of catchment.(Oblong, fan etc.)
- c) Details of the course of the main stream and its tributaries.
- d) Longitudinal slope of the main stream and average land slope of the catchment from the contours.
- e) Nature of soil in the catchment (rocky, sandy, loamy or clay etc.)
- f) Extent of vegetation (forest, pasture ,cultivated, barren, etc.). The details can be obtained from the following records:-

- i) Survey of India Topo sheets to a scale of 1:50,000.
- ii) Aerial photographs/Satellite imagery.

In some cases aerial survey of the catchment may be necessary.

g) Probable changes that may occur in the catchment characteristics assessed by enquiries from the right sources.

h) Information from the rainfall records of local or nearby rain gauges.

i) Other climatic conditions (like temperature, humidity, snow accumulation etc.) assessed either from map issued by or from the India Meteorological Department.

j) Changes in the course of the channel.

k) The nature of the material through which the channel flows (whether it consists of boulder, gravel, sand, clay or alluvium.). The description should be based also on actual bore hole particulars.

l) Bank erosion and bed scour observed at the bridge site in the case of alluvial rivers and the nature of the material transported.

m) The maximum observed scour depth in the vicinity of the proposed bridge crossing.

n) Full description of bridges (as given below) existing both upstream and downstream from proposed crossing including relief and overflow structures.

i) Type of bridge including span lengths and pier orientation.

ii) Cross section near the structure, including vertical clearance from water level to soffit of super structures and direction of the current during floods.

iii) All available flood history- high water marks with dates of occurrence, nature of flooding, afflux observed, damages caused with sources of information.

iv) Photographs of existing bridges, past floods, main channels, and flood plains and information as to the nature of drift, stream bed and stability of banks.

p) Factors affecting water stage at the proposed bridge site such as:-

i) High flood levels of other streams joining.

ii) Particulars of reservoirs and tanks existing or proposed to be constructed and approximate date of construction.

- iii) Flood control projects on the stream or other structures which affect the flow in the stream such as weirs, barrages, training works, spurs etc.
- iv) Tides, or back flow due to a confluence downstream.
- v) Character of floods:- Whether steady, flashy or eddy forming, etc.

2. A detailed map showing flood flowing patterns, location of proposed bridge, spill openings, if any and alignment of piers, should be prepared to a suitable scale. The map should indicate:-

- i) Contours at 1m intervals, stream meander, vegetation and man made changes, if any.
- ii) Three cross sections together with HFL, one on the centre line of the proposed bridge, one upstream and one downstream at 100 to 300m intervals.

3. In the case of minor bridges, the scope of data collection may be reduced to Sub paras 1 a to h, p(i), (ii), (iii) and 2 above.

### **307. Plan and cross section of Rivers**

For all important bridges, plan and cross sections showing the following particulars should be furnished subject to the provision that the Engineer may exercise his discretion as to the necessity for these plans and sections in mountainous country:

a) The plan should be drawn to a scale of 50 metres. to a cm of such portion of the river and its tributaries as may lie within a distance of about 2km. from the proposed bridge site or such further distance as the Engineer may consider necessary. The direction of the flow should be indicated by arrows.

b) Three cross sections for the river bed are required to be plotted to a natural scale of 5metres. to a cm. Where the width of the river in flood exceeds 1000 metres, the scale may be reduced. For river width greater than 500 metres, the cross section should be plotted in two halves. The cross sections should be taken at typical points selected at intervals of about 2 kms. On each cross section, the levels of the highest known flood, ordinary flood and ordinary low water should be indicated by lines with reduced levels. On the cross section taken on

the center line of railway, an elevation of the proposed bridge should be drawn to a scale in its proper position. The chainage should be indicated on the cross section. Where borings or trial pits have been made, their position, with a note on results should also be given.

### **308. Factors governing the choice of site**

The following factors should be considered in the choice of a site.

1. The reach of the river, especially the upstream should be straight.
2. The river in the reach should have a regime flow, free of whirls, eddies and excess currents.
3. The site should have a firm high banks that are fairly inerodible.
4. In the case of a meandering river, the site should be located near a nodal point. A nodal point is defined as the location where the river regime does not normally shift and the location serves as a fulcrum about which the river channels swing laterally (both upstream and downstream.)
5. The site should have suitable strata at a reasonable and workable depth for founding piers and abutments.
6. The bridge is normally located where the river section has minimum width and the bridge should be aligned normal to the river as far as possible.
7. Wide Khadir for bridge location should be avoided. Location of bridge with respect to Khadir width should be carefully decided. If the bridge is located near one end of the Khadir width and the khadir bank is non-erodible clay, one guide bound can be saved. However, longer length of approach at other end gets exposed and becomes vulnerable to river attack in this case. On the other hand, the central location of the bridge reduces length of approach open to river attack, minimises obliquity of approach, but requires provision of two guide bunds.
8. The bridge should not normally be located where frequent changes occur in the river course, tendency for aggradation or degradation is manifest and there is problem of bank erosion.
9. The approach bank should be secure and not be liable to flash floods or major spills during floods.

If the approach passes over braided channels which have connections with the main river upstream, there is always the danger of these channels getting activated some time or the other. If the spill is wide, the bank formed across will cause development of a parallel flow, which at times can become so large and swift as to cause erosion, bank slips or even breaches through the bank .

10. The approach bank should not pass through a heavy hilly terrain or marshy land nor cut across a major drainage so as to avoid expensive construction works.

11. Approach banks in the case of constricted bridges should avoid curvature.

**309. Design discharge (Q)**

The estimation of design discharge for waterway shall be based on (a) actual hydro-meteorological observations of the same or similar catchments (b) the computed flood with probable recurrence intervals of 50 years. The recurrence interval can be modified at the discretion of Chief Bridge Engineer based on the importance of the line. For further details reference may be made to paras 4.2 and 4.3 of the I.R.S. Code of Practice for the design of Substructures and Foundations of Bridges.

**310. Design discharge for foundations (Qf)**

To provide for an adequate margin of safety against any abnormal flood exceeding the design discharge (Q), the foundations, protection works and training works shall be designed for a higher flood discharge. This discharge shall be computed by increasing the design discharge (Q) estimated according to para 309, by the percentage indicated below:

i)	Catchment upto 500 sq.km.	30%
ii)	Catchment more than 500 sq. km. and upto 5000 sq. km.	30% to 20% (decreasing with increase in area)
iii)	Catchment more than 5000 sq.km. and upto 25,000 sq.km.	20% to 10% (decreasing with increase in area)
iv)	Catchment more than 25,000 sq.km.	Less than 10% (at the discretion of the Chief Bridge Engineer).

### 311. Design of waterways

1. In the case of a river which flows between stable high banks and which has the whole of the bank-to-bank width functioning actively in a flood of magnitude Q, the waterway provided shall be particularly equal to the width of the water spread between the stable banks for such discharge. If however, a river spills over its banks and the depth of spill is appreciable, the waterway shall be suitably increased beyond the bank-to-bank width, in order to carry the spill discharge as well.

2. In the case of river having comparatively wide and shallow section, with the active channel in flood confined only to a portion of the full width from bank to bank, constriction of the natural waterway would normally be desirable from both hydraulic and cost considerations. A thorough study of both these factors shall be made before determining the waterway for such a bridge.

The waterway shall be designed as per para 4.5 of the I.R.S. Code of practice for the design of substructures and foundations of bridges.

### 312. Vertical Clearance

1. The minimum clearance for bridges excluding arch bridges, syphons, pipe culverts and box culverts from the water level of design discharge (Q) including afflux shall be as under:

Discharge in Cumecs	Vertical clearance in mm
0 - 30	600.
31 - 300	600 - 1200 (pro-rata)
301 - 3000	1500
Above 3000	1800

2. In the case of arch bridges, minimum clearance measured to the crown of the arch shall be as under:

Span of arch	Clearance
Less than 4 m	Rise or 1200 mm. whichever is more.
4.0m to 7.0m	2/3 rise or 1500 mm whichever is more.
7.1m to 20.0m	2/3 rise or 1800 mm whichever is more.
Above 20.0 m.	2/3 rise.



3. Syphons, pipe and box culverts are designed as pressure conduits therefore no clearances are considered necessary for these structures.

4. While rebuilding bridges on existing lines or building new bridges on parallel doublings, the clearance stipulated above can be relaxed by Chief Bridge Engineer with the consideration to the past history, to the extent shown below provided:

a) adoption of the prescribed values of clearance would result in heavy expenditure and/or serious difficulties in construction, and

b) the clearance can be safely reduced from those stipulated under sub para 1 above.

Discharge (Cumecs)	Reduced Clearance (mm)
Less than 3	300
3 to 30	300 - 400 (Pro-rata)
31 to 3000	400 - 1200 (Pro-rata)

5. While executing works other than rebuilding a bridge, the existing clearance may be retained.

6. Where a tendency has been observed for the bed-level to rise, a clearance shall be provided taking this factor into account.

### 313. Free board (F)

1. The free board from the water level of the design discharge (Q) to the formation level of the Railway embankment or the top of guide bund including afflux shall not be less than 1m. In cases where heavy wave action is expected, free board shall be increased suitably.

2. In special circumstances, where the free board can be safely reduced and where adoption of the prescribed values would result in heavy expenditure and/or serious difficulties in construction, the free board may be relaxed at the discretion of the Chief Bridge Engineer as indicated below:

Discharge (Cumecs)	Minimum free board (mm)
Less than 3	600
3 to 30	750

3. While executing works other than rebuilding a bridge or extending it for doubling purpose, the existing free board may be retained after taking measures for safety as considered necessary by Chief engineer.

#### **314. Standard of substructure for new railway lines**

1. For bridges built on new lines involving either spans of 24.4 m. and above or waterways of 304.8m. and above, or well foundations, a decision should be taken whether the substructures should be built:

- a) In the case of Metre gauge bridge to suit broad gauge loading, or
- b) In the case of broad gauge single line bridge to allow for future doubling.

2. In the survey report, the additional cost of building the substructures as stated above should be furnished.

#### **315. Final Project report in the case of Important Bridges**

After the location is approved, detailed investigation covering all the above aspects should be carried out and the detailed estimate prepared. Wherever necessary, model studies may be carried out. This report and the estimate and drawings should be in sufficient details, so that the sanction to the project can be issued and the detailed design as well as tendering for the work can be commenced immediately thereafter.

#### **316. Choice of foundations for bridges**

1. General:

a) The following types of foundations are normally provided for Railway Bridges, depending on the site conditions:

- i) Open foundations.
- ii) Pile foundations.
- iii) Well Foundations.

b) The decision on span length has to depend upon the ratio of the cost of substructure including the foundation versus the cost of superstructure. Generally it is most economical when this ratio is one.

2. Open foundation is suitable for bridges where rock or firm subsoil is available at shallow depth and there is not much scour and flowing water in the stream.

3. Pile foundation can be quite economical, particularly where the foundations have to be built very deep or taken through deep layers of soil subjected to little scour. Larger diameter piles can be provided to take care of large horizontal forces when the foundations are deep. Larger diameter piles can also be provided for foundation depths beyond the limit of pneumatic operations.

4. Well foundation provides a solid and massive foundation for heavy loads and large horizontal forces. This has a larger cross sectional area and hence the total foundation bearing capacity is much larger than what may be offered by a cluster of piles. The well provides a very good grip when taken sufficiently deep and hence is most suited for river beds subjected to heavy scour.

### **317. Approval of drawings for new lines, doublings and Gauge Conversion**

In case of doublings/gauge conversion, General Arrangement Drawings for all major bridges, bridges where linear water way is being reduced or vertical clearances are inadequate and where construction is likely to affect any of the existing bridges, shall be approved by Chief Bridge Engineer. Besides this, General Arrangement Drawings for bridge constructed on new lines, which affect the existing bridges, shall also require the approval of Chief Bridge Engineer.

□□□

## CHAPTER - IV

### CONSTRUCTION OF FOUNDATIONS FOR BRIDGES

#### 401. Setting the lay out of Bridges

##### 1. General

a) It is necessary to accurately lay out the centre line of a bridge and the locations of its piers and abutments and to establish a system by which they can be checked with ease during the progress of the work.

b) Position of the principal reference lines and level pegs should be so selected and laid that they are easily accessible for check during the execution of the work .

c) The Principal reference lines to be established are the longitudinal centre line and the transverse centre lines of abutments and piers. If the bridge is on a curve, the tangent points of the curve and the directions of the tangents at either ends should also be established by pegs.

##### 2. Setting out bridges without a base line :

Where deep excavations are not involved and where there is no water flow in the river during the working season, setting out primarily involves fixing the alignment correctly using a theodolite. The distance between the abutment at either end and the nearest pier and the pier - to-pier distance can be set out by directly measuring and marking the centres using a good steel tape (See Annexure 4/1).

The centre points of each structure (pier or abutment) should be punch marked on a flat or angle iron piece fixed flush with the top of a concrete block at the correct location .

##### 3. Setting out bridges with the help of a base line :

a) Where deep excavation, pile driving or well sinking is involved, and where there is standing water, base lines are set out at right angle to the centre line of the bridge, one on either end on the high banks, or on one side of the bridge or anywhere between the abutments where level ground is available.

b) The actual position of the piers/abutments is determined by the intersection of three sight lines, one along the alignment sighted from stations located on either end, a second from a station on the base line on the down stream side and a third from a point on the base line on the upstream side. Theoretically all these three lines should intersect at one point. Normally a triangle of error gets formed and the correct centre is fixed by judgment within this triangle. (Refer Annexure 4/2) .

4. Important points to be observed while setting out base lines:

a) Linear measurement should be carried out with invar tape or Electronic distance measuring equipment.

b) Concrete pillars with steel plates fixed over them should be located at tape lengths for accurate measurements.

c) Spring balances should be used for giving specified tension to the tape.

d) Tape readings should be corrected for tension, temperature and slope.

#### **402. Pipe and box Culverts with open foundation**

Pipe and box culverts can be constructed after removing the top soil in bed to the required depth and replacing it with a layer of lean concrete after the bed is levelled and well consolidated by ramming or rolling. Reference may be made to Annexure 4/3 for a typical arrangement. Pipe and box culverts should not normally be provided where the bed is likely to be scoured .

#### **403. Other Bridges with open foundation**

1. Open foundations must rest on a stratum with adequate bearing capacity. In order to reduce the bearing pressure the base can be sufficiently widened by providing footings. The footings will rest on a lean concrete bed of adequate thickness.

2. The foundation should be taken to a depth not less than 1.75 metres below the lowest anticipated scoured bed level in ordinary soil. In rocky soil, it will be adequate if it is properly keyed into the rock for a minimum of 0.3 metre in case of hard rock and 1.5 metres in case of soft rock. Sloping rock may be suitably benched. Fissures and weathered rocks should be avoided. A typical arrangement is shown in Annexure 4/4.

3. In soft soils, rafts may be provided as foundation. Such rafts should be protected by means of suitable aprons and cut off walls or launching aprons, both on the upstream and downstream sides to prevent undermining of the foundations .

4. Excavation for open foundations with shoring :

Excavation should be done in such a way that the surrounding soil can stand by itself by suitable sloping the sides. When excavations have to be deep or when the side slopes are not stable, suitable shoring may be provided from top, using timber planks, walling pieces and struts. Typical arrangements of shoring are shown in Annexure 4/5. In deep foundations and large size excavations, where the seepage is heavy, suitable pumps may be used for dewatering. A small sump on the side or corners should be provided for collection of the water to be pumped.

#### **404. Excavation using coffer dam**

1. Shallow foundations :

Where excavation is required to be done under flowing or standing water, coffer dams of steel sheet pile, RCC or timber may be constructed. Driving is done from a floating platform. Annexure 4/6 shows a typical arrangement with steel sheet piling.

2. Deep foundations :

When the depth of water is more than 10 metres, coffer dams with single wall sheet pile will not be adequate. In such cases double wall sheet pile coffer dams as shown in Annexure 4/7 may be provided. The two rows of sheet piles are connected by tie rods and the space in between is filled with rock or soil. Suitable beams are provided on the inside.

## **PILE FOUNDATIONS**

#### **405. Choice of pile materials**

RCC piles both driven and bored may be used. Driven piles may be either precast or cast in-situ. Timber piles may, however, be used for temporary restoration of traffic. They should, be replaced with permanent structures. A typical arrangement of a temporary wooden pile bridge is shown in Annexure 4/8.

**406. Soil Exploration for design and construction of piles**

For the satisfactory design and construction of piles, detailed soil exploration to a depth generally not less than 10 metres below the anticipated level of pile tip (unless bed rock or firm strata has been encountered earlier) should be carried out and the following particulars are collected.

- a) Ground water table and its tidal and seasonal fluctuations;
- b) Soil profile and bore hole log;
- c) In-situ bulk and dry density ;
- d) Index properties of soil ;
- e) Shear properties of soil. If required Standard Penetration Test (SPT) may be done;
- f) Consolidation properties, in case of clays ;
- g) Chemical analysis of soil and ground water to identify sulphate and chloride content or any other deleterious chemical content.

Additional data such as high flood level, maximum scour depth , normal water level during working season, etc. should also be collected.

**407. Classification of pile foundations**

Piles may be classified as under :

**1. Based on the manner of transfer of load.****a) Friction piles :**

These piles transfer the load primarily by skin friction developed along their surface. They are used in soils not subjected to scour.

**b) Bearing piles :**

These piles transfer the load primarily by bearing resistance developed at the pile tip or base, without taking into account the frictional resistance. They are generally used in hard stratum.

**c) Bearing-cum-friction piles :**

These piles transfer the load both by bearing and friction

**2. Based on construction methods :**

- a) Driven Pre-cast piles ;
- b) Driven cast in-situ piles;
- c) Bored cast-in-situ piles.

3. Large diameter bored piles of more than one metre diameter are normally used for Railway bridge construction.

#### **408. Selection of type of piles**

The following factors are to be considered while selecting the type of piles :

1. Availability of space and head room :

Driven piles require large area and headroom since they need larger and heavier driving rigs. Bored piles, however, require comparatively smaller space.

2. Proximity to the structure :

Driving causes vibration of the ground which may damage nearby structures. Hence bored piles are preferred in these cases.

3. Reliability :

Driven precast piles ensure good quality as they are cast under controlled condition. In cast in-situ piles, segregation of concrete is possible in water logged areas.

4. Limitation of length :

Cast-in-situ piles can be formed to any desired length. The length of driven piles normally does not exceed 25 to 30 m depending on the capacity of the driving equipment.

#### **409. Spacing of piles**

1. The spacing of piles is determined based on the type of soil and empirical approach keeping in view the following aspects:

a) Practical aspects of installing the piles .

b) The nature of the load transfer to the soil and possible reduction in the bearing capacity of a group of piles thereby

2. Where piles are found on a very hard stratum and derive their capacity mainly from end bearing, the spacing will be governed by the competency of the end bearing stratum. The minimum spacing in such cases shall be 2.5 times the diameter of the pile shaft.



3. Piles deriving their bearing capacity mainly from friction shall be sufficiently apart to ensure that the zones of soil from which the piles derive support do not overlap to such an extent that their bearing values are reduced. Generally, the spacing in such cases shall not be less than 3 times the diameter of the pile shaft.

4. In the case of loose sand or filling, closer spacing than in dense sand may be possible since displacement during filling may be absorbed by vertical and horizontal compaction of the strata. Minimum spacing in such strata may be twice the diameter of the pile shaft. This is applicable for driven piles only.

5. Normally centre to centre spacing should not be more than  $4d$ , where  $d$  is the diameter of pile shaft. In the case of piles of non circular cross section, diameter of the circumscribing circle shall be adopted.

#### **410. Load carrying capacity of a pile / group of piles**

1. Load carrying capacity of a single pile :

a) The ultimate bearing capacity of a pile may be assessed by means of a dynamic pile formula, using the data obtained during driving of the piles or by a static formula on the basis of soil test results or by a load test. Reference may be made to IS : 2911-1979 Part - I, section -I (revised) for the details of dynamic and static formulae.

b) For non-cohesive soils, Hiley's formula is more reliable than other formulae . (Appendix-B of IS 2911 Part -I, section -I ). Hiley's formula is not reliable in cohesive soils.

c) Load test is most desirable. The load test on pile should be carried out four weeks after casting the pile

d) Resistance due to skin friction will be available only below the scour line and this must be taken into account in all the three methods.

2. Factor of safety for Pile Foundations :

a) The factor of safety shall be judiciously chosen after considering the following :

- i) Reliability of the ultimate bearing capacity of pile ;
- ii) Type of superstructure and type of loading ;
- iii) Allowable total/differential settlement of the structure ;
- iv) Experience of similar structures near the site.

b) The minimum factor of safety with static or dynamic formula shall be 2.5. The value to be selected for the factor of safety shall, however, take into account, the allowable total settlement and differential settlement of the structure as a whole. In the case of load test, a minimum factor of safety of 2 shall be applied which may be suitably increased for unfavourable conditions, if any.

The load carrying capacity shall be minimum of the values arrived at by the three methods.

### 3. Bearing capacity of a pile group :

The bearing capacity of a pile group may be either of the following:

- i) Equal to the bearing capacity of individual piles multiplied by the number of piles in the group, or
- ii) It may be less than the above.

The former holds true in the case of friction piles, cast or driven into progressively stiffer materials or in end bearing piles. In friction piles installed in soft and clayey soils, it is normally smaller. For driven piles in loose sandy soils the group value may be higher due to the effect of compaction. In such a case, a load test should be made on a pile from the group after all the piles in the group have been installed.

NOTE; Reference should be made to IS : 2911 (1979) Code of Practice for Design and Construction of Pile Foundation (Revised) for further details while designing the piles and pile groups.

## 411. Construction of pile foundation

### 1. Driven precast piles :

Piles can be driven either with a drop hammer or by the use of a single acting/double acting hammer. A typical rig which can be used for driving precast piles as well as the casing for cast in-situ piles is shown in Annexure 4/9. When the pile driving has to be done in water the equipment can be mounted on pontoons.

## 2. Driven cast-in-situ piles :

A steel casing pipe with a shoe at the bottom is driven first to the required depth. The reinforcement cage of the pile is then lowered inside the casing and the pile concreted. If possible, the concrete is tamped and compacted as it is poured, or a high slump concrete is poured through a tremie. As the concreting of the pile proceeds upwards, the casing is withdrawn keeping a suitable over lapping length.

## 3. Bored cast-in-situ piles :

A guide casing of 3 to 4 m length is provided on top of the bore hole and is driven with the help of a bailer. Further boring below this casing is carried out by chiselling and the side walls are kept stable by circulating bentonite slurry inside the bore hole. The Bentonite clay used in the operation should conform to provisions made in IS : 2911 - Part -1, section -2. After reaching the founding level, the chisel is removed, the bore hole flushed and the reinforcement cage lowered into the hole and held in position by tack welding it to the support bars at the top of the casing.

After this the concreting is carried out by using a "tremie". The concreting is continued till a good quality concrete is seen at the top of the bore hole. The concrete used is a high slump mix (not leaner than M 20 grade ). Cast-in-situ piles in which the steel shell is left in the ground ensures the quality of concrete and offers corrosion protection in soils containing chlorides and sulphates .

### **412. Permissible tolerance while driving piles**

#### 1. Control of alignment :

Piles should be installed as accurately as possible as per the designs and drawings either vertically or to the specified batter. As a guide, for vertical piles a deviation of 1.5 percent and for raker pile a deviation of 4 percent should not normally be exceeded.

2. Piles should not deviate more than 75mm or  $D/10$  in case of bored cast-in-Situ piles having diameter more than 600mm whichever is more, from their designed position at the working level of the piling rig. In the case of a single pile in a column, positional tolerance should not be more than 50 mm (100mm in case of piles having diameter

more than 600mm). Greater tolerance may be prescribed for piles driven over water and for raker piles. For piles to be cut-off at a substantial depth, the design should provide for the worst combination of the above tolerances in position and inclination. In case of piles deviating beyond these limits and to such extent that the resulting eccentricity can not be taken care of by a redesign of the pile cap or pile ties, the piles should be replaced or supplemented by one or more additional piles.

NOTE: In the case of raker piles upto a rake of 1 in 6, there may be no reduction in the capacity of the pile unless otherwise stated.

3. Any deviation from the designed location, alignment or load capacity of any pile shall be noted and adequate measures taken well before the concreting of the pile cap and plinth beam.

#### **413. Sequence of piling**

1. In a pile group the sequence of installation of piles shall normally be from the centre to the periphery of the group or from one side to the other.

2. Consideration should be given to the possibility of doing harm to a pile recently formed by driving the tube nearby before the concrete has sufficiently set. The danger of doing harm is greater in compact soils than in loose soils.

3. Driving piles in loose sand tends to compact the sand which, in turn, increases the skin friction. Therefore, the order of installing of such a pile in a group should avoid creating a compacted block of ground into which further piles cannot be driven.

4. In case where stiff clay or compact sand layers have to be penetrated, similar precautions need be taken. This may be overcome by driving the piles from the centre to outward or by beginning at a selected edge and working across the group. However, in case of very soft soils, the driving may have to proceed from outside to inside so that the soil is restrained from flowing out during the operations.

#### **414. Defective piles**

1. In case defective piles are formed, they shall be removed or left in place whichever is convenient without affecting the performance of the adjacent piles or the group as a whole. Additional piles shall be provided to replace them as necessary.

2. If there is a major variation between the depths at which adjacent piles in a group meet refusal, a boring shall be made nearby to ascertain the cause of this difference. If the boring shows that the soil contains pockets of highly compressive material below the level of the shorter pile, it may be necessary to take all the piles to a level below the bottom of the zone which shows such pockets.

#### **415. Tremie Concreting**

The following precautions are to be taken while doing the work :

1. The concrete should be coherent, rich in cement (not less than  $370 \text{ kg/m}^3$  ) and of slump between 150 and 180 mm.

2. When concreting is carried out under water, a temporary casing should be installed to the full depth of the bore hole or 2m into non collapsible stratum so that fragments of ground cannot drop from sides of the hole into concrete as it is placed. The temporary casing may not be required except near the top when concreting under drilling mud (Bentonite slurry.)

3. The hopper and the tremie should be a closed system embedded in the placed concrete, through which water cannot pass.

4. The tremie should be large enough with due regard to size of the aggregates. For 20 mm sized aggregate the tremie pipe should be of diameter not less than 200 mm. Aggregates more than 20 mm in size shall not be used.

5. The first charge of concrete should be placed with a sliding plug pushed down the tube ahead of it or with a steel plate of adequate charge to prevent mixing of concrete and water. However plug should not be left in the concrete as a lump.

6. The tremie pipe should always penetrate well into the concrete with an adequate margin of safety against accidental withdrawal of the pipe surging to discharge the concrete.

7. The pile should be concreted wholly by tremie and the method of deposition should not be changed part way up the pile, to prevent laitance from being entrapped within the pile.

8. All tremie tubes should be scrupulously cleaned after use.

9. Normally concreting of the piles should be uninterrupted. In an exceptional case of interruption of concreting, but which can be resumed within 1 or 2 hours, the tremie shall not be taken out of the concrete. Instead, it shall be raised and lowered slowly, from time to time to prevent the concrete around the tremie from setting. Concreting should be resumed by introducing a little richer concrete with a slump of about 200 mm for easy displacement of the partly set concrete. If the concreting cannot be resumed before final setting of concrete already placed the pile so cast may be rejected or accepted with modifications.

10. In case of withdrawal of tremie out of the concrete either accidentally or to remove a choke in the tremie, the tremie may be reintroduced in the following manner to prevent impregnation of laitance or scum lying on top of the concrete deposited in the bore.

The tremie shall be gently lowered on to the old concrete with very little penetration initially. A vermiculite plug should be introduced in the tremie. Fresh concrete of slump between 150 mm and 175 mm should be filled in the tremie which will push the plug forward and will emerge out of the tremie displacing the laitance/scum. The tremie will be pushed further in steps making fresh concrete sweep away the laitance/scum in its way. When tremie is buried by about 60 to 100 cm, concreting may be resumed.

11. In case of concreting through tremie or such tubes which are subsequently withdrawn, the concrete shall be placed in sufficient quantity to ensure that during withdrawal of the tube a sufficient head of concrete is maintained to prevent the in-flow of soil and water or bentonite slurry (Refer Annexure 4/10).

12. The top of the concrete in a pile shall be brought above the cut-off level to permit removal of all laitance and weak concrete before capping and to ensure good concrete at the cut off level for proper embedment into the pile cap.

#### **416. Acceptance of pile**

For acceptance of piles, vertical and lateral load, testing of piles as required will be carried out as per procedure laid down in IS : 2911 (Pt-IV) "Code of Practice for Design and Construction of Pile Foundation -Load test on piles."

---

## WELL FOUNDATIONS

### 417. Types of well

1. The types commonly used are :-

- i) Circular
- ii) Double -D

For bridges with single line circular wells are adequate. Where the pier length is larger as in the case of double line bridges, double-D wells may be used.

2. The circular well is simple to construct, easy to sink and has uniform strength in all directions. It can be better controlled against tilt and tilt correction is also easier. The only disadvantage is the limitation in size which restricts its use to bridges with smaller piers.

3. The shape of Double-D well facilitates easy casting and sinking due to presence of two dredge holes. The overall length of the well generally is restricted to twice the width.

### 418. Components of wells

1. Annexure 4/11 shows the cross section of typical well foundation with its components.

2. Well curb including cutting edge :

The bottom portion of the well is tapered and is called the well curb. It should be strong enough to transmit the design loads to the bottom plug. The inclination of the inner face of the curb should preferably be not more than 30 degree except in sandy strata, where it may go upto 45 degree. Reinforced well curbs with a minimum reinforcement of 72 kg/m<sup>3</sup> excluding bond rods are suitable for depths upto 25 metres. For depths more than 25 metres, all steel well curbs are preferable. In case blasting is anticipated, the inner face of curb should be protected by steel plates or any other means to sufficient height.

The cutting edge, which is an integral part of the well curb, is usually made of rails or mild steel plates and angles and is fabricated in 3 or 4 parts.

The cutting edge should be properly anchored to the well curb. In the case of double -D wells the bottom of the cutting edge of the intermediate walls may be kept 300 mm above the outer cutting edges to prevent rocking.

A typical RCC well curb including cutting edge is shown in Annexure 4/12.

### 3. Well steining :

#### a) General :

Well steining is built of mass concrete or reinforced concrete. Bond rods distributed uniformly on both the faces of the steining shall be provided at a rate not less than  $9 \text{ kg/m}^3$  to bond the units of the steining during the process of construction. They shall be tied up by providing adequate horizontal hoop reinforcement which shall not be less than  $9 \text{ kg/m}^3$ . The cover for the rods shall not be less than 75 mm.

#### b) Thickness of steining of cement concrete wells :

The well steining should be of sufficient thickness (Not less than 1000 mm) so that

- i) sinking is possible without excessive kentledge ;
- ii) the steining is strong enough to resist damage during sinking;
- iii) tilt correction is possible without damage to the well ;
- iv) the steining is strong enough to resist earth pressure in conditions like sand blow or sudden drop of well during sinking; and
- v) stresses developed during sinking and in service conditions are within permissible limits.

### 4. Bottom plug :

The dredge hole should be filled up with M-15 grade cement concrete under water. The bottom plug should fill up the entire portion of the cone and upto 300 mm above the top of curb. The bottom plug concreting should be done in one continuous operation.

### 5. Top plug :

A 300 mm thick plug of cement concrete M-10 grade shall be provided over the hearting which shall normally be done with sand.



#### 6. Well cap :

The bottom of the well cap shall, as far as possible, be located 300 mm above low water level. All the longitudinal bars from the well steining shall be anchored into the well cap. The well cap shall be designed as a slab resting on the well steining.

#### **419. Pitching of the cutting edge and well curb**

The curb should be generally pitched at about 15 cm to 30 cm above the low water level. The pitching level may be kept higher if the water level in the river is subjected to greater fluctuations like in tidal areas. In case the site is dry, excavation should be carried out upto the level at which the well curb is proposed to be pitched and the centre of the well curb carefully marked. The well curb should then be assembled on wooden blocks or sand bags placed at intervals of about 1.5 metre.

In case the well has to be sunk in water, an island is formed, and the top of the island is levelled and compacted lightly and marking for setting the cutting edge is done on the level surface.

The concrete should be of mix not leaner than M-20 grade. After concreting the well curb the outer shuttering may be taken off after 24 to 48 hours depending on the temperature. The inside conical shuttering can be taken off after 72 hours. The wooden block supports can be taken out alternatively one by one, supporting the well curb on sand bags using a jack, for the purpose. Vertical gauges on four sides of the well from the centre of the cutting edge should be provided to monitor the verticality of the well during sinking. RCC well curb should be allowed to set for at least one week before sinking is started. A well is most unstable in the beginning when it has no grip in the sand or when the grip is very small. The chances of tilting increases considerably if the well is made top heavy by raising the masonry of the steining too high in the first instance. The best course is to sink the well curb alone after allowing it setting time without raising the steining above it.

#### **420. Concreting of steining**

The well steining should be built up in stages initially 1.20 to 1.50 metres at a time, as it is gradually sunk through the soil, keeping sufficient free board above the water level. Once well has acquired

a grip of about 6 metres, the steining can be raised 3 metres at a time to obtain a better rate of progress. Inner shuttering and bracing should not be removed within 24 hours of casting.

#### **421. Sinking of wells in water**

1. The sinking of well is done by removing the soil with grabs or chiselling and drawing out the soil. Sinking of steining should not be done within 48 hours of casting.

2. In stagnant water and in water with velocity upto about 2.0 m/s and of depth upto about 5 metres, construction of island may be resorted to. In greater depths, the use of steel caissons would become unavoidable.

3. Construction of island :

a) The island should provide sufficient working space of about 2 to 3 metres all round the well. A minimum free board of 0.6 metre should always be provided.

b) For depths of water upto 1 metre, an island may be constructed by laying a few rings of sand bags enclosing the area of the island and filling with sand. Boulders should not be used in the construction of island as they may find a way inside the island and obstruct the sinking of the well. For greater depths, two rows of piles 1.5 metre apart at a spacing of 1 metre enclosing the area of the island may be provided. Upto 1.5 metre depth, bamboo piles may be used and timber ballies may be used upto 3 metre depth. The piles are lashed together with strap, wire ropes or coir ropes. Bamboo matting is then fixed along the inside faces of the piles and the space between the mattings is filled with puddle or sand bags. Beyond 13 metre depth, steel sheet piles should be used. The piles should have a grip of at least 3 metres. Sand bags should be dumped outside the island as a protection against scour. In cases, where velocity is high, wire netting (crates) filled with boulders may be used. (Refer Annexure 4/13).

#### **422. Sinking of wells using caissons**

1. In deeper channels and swift rivers, caissons built of steel plates suitably strengthened by angle iron stiffeners and further strutted and tied together by MS angles may be used. Caissons are lowered through water and pitched in position before commencing the sinking.

## 2. Assembling and launching of caissons :

Caissons can be assembled at site itself and launched straight away using barges or can be assembled when the river bed is dry and launched when water level in the river rises.

In the first method, a temporary platform is constructed over two barges suitably anchored and a gantry is erected over the platform. The caisson is assembled on the temporary platform. After testing for leakages, the caisson is lifted from the platform and lowered in position after removing the temporary platform (Annexure 4/14)

In the second method, the caissons are assembled, tested and kept ready duly filled with water on the river bed when it is dry. When the water level rises, the water in the caisson is pumped out and they are toed into position. The draught can be reduced by covering the dredge holes with steel plates and pumping compressed air into them.

As an alternative method, caissons can be assembled on the river bank and brought into the water using the slip ways after which they can be toed into position for launching and grounding. This method of assembling the caissons in dry docks and launching them is very expensive and resorted to only under special circumstances.

## 3. Grounding of caissons:

While lowering, the caisson should be held firmly in position between the barges with greased wooden packings as shown in Annexure 4/15.

The barges should themselves be firmly anchored to the river bed. The caisson should be lowered slightly at first by pumping in water or releasing the compressed air from the dredge holes. Later the rate of lowering can be increased by adding weight either by concrete or water. It should be ensured that a minimum free board of 0.6 metre is maintained throughout the grounding operations. Once the caisson has touched the bed, sand bags should be deposited around to contain the scour. The caisson is then set in its correct position. Further weight is added by pouring concrete in the caisson and dredging operations are commenced.

**423. Process of open sinking of wells**

1. Sinking of smaller wells may be done with the help of timber shear leg, derrick or timber scotch. For shallow depths, grabbing and removal of the earth can be done manually. For greater depths and where the sub soil water level is high, suitable dredger may be used. The grab can not be operated in the blind area below the curb. Hence, these are suitable for the wells with thinner steining. Steam or diesel winches of suitable capacity can be used for operating the grabs or dredgers. For faster sinking of wells of 6 metre dia and above, suitable cranes may be used.

**2. Well Sinking through clay and hard strata :**

a) In stiff clay strata or in strata with compact sand, shingle and boulders, the use of rail chisel may be required. Use of chisels can be avoided if hammer grabs are used.

A sketch of rail chisel commonly in use on Indian Railways is shown in Annexure 4/16.

b) For sinking through stiff clay and other hard strata buoyancy effect of the soil may be reduced by dewatering the well to increase its effective weight.

c) If due to heavy skin friction, the well is held in a floating condition, air or water jets may be used on the outer periphery of the well for reducing the friction. For this purpose pipes of 4 to 5 cm. dia. fitted with nozzles can be incorporated in the well close to the outside periphery, particularly in the curb portion and also for some height of the steining above.

d) When any of the above methods is not effective, a few sticks of gelignite can be detonated under the water below the cutting edge. This results in shaking of the well and reducing the skin friction, which helps in its further sinking. Charging should be started with small quantities in each dredge hole at a time and gradually increased. When there is more than one dredge hole, such charging and detonation should be done in all the holes simultaneously.

### 3. Precautions to be taken during well sinking:

#### a) Blowing of Sand:

Great caution is necessary when dewatering of well is done at shallow depths or when the well has not gone into the soil by at least 1 metre. The difference in the hydraulic pressure inside and outside the well may create a passage for rush of sand from outside the well resulting in “blowing of the sand”. Sand blowing can endanger the safety of men working inside the well and can also cause sudden tilting of the well. Seepage of water should be carefully watched during sinking and should be checked by putting sand bags over the area where such seepage is noticed. In severe cases of sand blowing, large quantity of the sand is sucked into the well and a funnel shaped depression is formed outside the well as shown in Annexure 4/17. Empty gunny bags and branches of the tree with green leaves may be thrown into the funnel and dredging continued till the sand blow gets arrested. The well can then be dewatered completely and excavation continued.

#### b) Quick sand condition:-

Quick sand conditions may occur when fine sand or silt underlie an impervious layer of clay with a considerable hydraulic pressure below the clay layer. As soon as the layer of clay is pierced through, a steep hydraulic gradient is established across a fine sand or silt under the clay and it either starts rushing upwards or is in a state of incipient motion. It has no shear strength in this state and allows the well to sink into it without offering any resistance. In most cases, the sand rises to a considerable height above the cutting edge and remains there in spite of continuous dredging. The problem can be faced to a certain extent if the steining of the well is raised to a considerable height when the cutting edge is well within the clay layer. The level of water inside the well should also be raised by pumping in water.

Dewatering should not be tried under any circumstance and no one should be allowed inside the well when quick sand condition develops. By keeping the water level inside the well higher, a hydraulic gradient is established in the reverse direction and the quick sand condition is not allowed to develop.

Even if it does develop, there is considerable margin of safety and the well does not sink below the bed level.

c) While sinking wells in deep water, divers with their equipment should be present for emergencies.

#### **424. Tilt and shift of the well**

##### 1. Limits of tilt and shift :

a) As far as possible wells shall be sunk without any tilt and shift. A tilt of upto 1 in 100 (1%) and a shift of  $D/40$  subject to a maximum of 150 mm can be permitted.

b) Excessive tilt and shift, which cannot be corrected, should be taken into account for rechecking the design of the well and the resulting foundation pressure.

c) The gauges marked at quarter points on the outer periphery of the steining starting from the bottom of the cutting edge mentioned earlier are used for checking the tilts. Water level readings on all the four gauges are observed frequently to get an idea of the direction and extent of tilt. Where the well is not sunk through water, plumb bobs are used on all four sides to judge the verticality of the well. It should be noted that plumb bobs are used only for checking for tilt during sinking and should never be used while building up the steining.

##### 2. Tilt correction :

Depending on the site conditions, any one of the following methods may be adopted either separately or in combination with others for the rectification of tilt which may occur due to the well encountering very soft material on one side and hard material on the other side or when there is a log of wood or a big boulder under the cutting edge on one side of the well.

##### a) Eccentric dredging :

The dredging is confined to the higher side and is done very close to the inside face of the steining and even a little under the steining.

##### b) Eccentric loading :

The side which is higher is loaded either by placing kentledges on the steining or by placing the load on a cantilevered platform (Annexure 4/18). Eccentric dredging should also be carried out to aid the tilt correction.

## c) Applying pull to the well :

Light pull can be applied to a well by taking a wire rope round the well and anchoring the tackle to a dead man anchorage or a large tree if available in the vicinity. The tackle is worked by a winch and tension is maintained as sinking progresses (Annexure 4/18).

For applying heavy pull, wire ropes are taken round and fixed to a large dead man anchorage. Rails or other kentledges are then placed on the wire ropes to develop high tension and the tilt gets rectified as the well sinks (Annexure 4/18)

## d) Applying push to the well :

Light push can be applied by driving a strut between the well and the bank. The strut is made tight by driving wedges. For applying heavy push, two timbers or struts of steel of suitable section are tied together in the shape of a nut cracker with the handles spread apart and the load is placed at the hinge. Care should be taken to see that the push is not excessive.

e) Packing the low side of the well with sand bags under the splayed portion.

This can be adopted only when sinking is done under dewatered conditions either by pumping or using compressed air. The side which is lower is packed with sand bags and excavation is carried out only on the high side. This method should be used cautiously if the depth of the well is shallow and when the well is resting on a sloping rock surface.

**425. Use of divers for sinking**

When dewatering is not possible and the use of pneumatic equipment for sinking is uneconomical, divers can be deployed for the removal of obstruction or clearing the strata. No man suffering from any chronic disease, alcoholic excess, ear or heart troubles or having a sluggish blood circulation or who has excess of fat should be employed as a diver. Theoretically a diver can work upto a maximum depth of water of 75 metres. But in practice it may be limited to about 35 metres. Any diver who will be employed in depths beyond 10 metres should be medically certified. The descending and ascending should be done slowly so that the diver can adjust himself to the pressures at various

depths. Durations of ascends and stoppages at various depths and stay under water at various pressures as laid down in the relevant British standard Specifications should be strictly adhered to.

#### **426. Pneumatic sinking of well**

1. Pneumatic sinking is used when other methods are not found feasible, particularly when the wells have to pass through considerable depths of intervening layers of rock or when the bed is full of large boulders or interlocked small boulders. This method may be employed for depths varying from 12 metres to 33 metres.

2. The inside of the well is made into a closed air tight box chamber and all water from this chamber is expelled out by letting in compressed air. The pressure of air inside the chamber should be maintained at approximately  $0.12 \text{ kg/cm}^2$  above atmospheric pressure per metre depth below water level.

The dredging operation may be carried out inside the chamber in near dry condition. The compressed air arrangements are then removed and sand filling etc. of the well are completed as for the open dredging.

The working chamber must be practically air and water tight and yet there must be an opening for men to enter and leave the chamber, as well as an inlet and outlet for materials. These opening are provided with vertical shafts and air locks. A typical arrangement showing the chamber with the vertical shaft and air lock is at Annexure 4/19.

3. Precautions while working in air lock chamber :

a) The lock usually becomes warm and water is required to be sprayed on its outside to keep the temperature down.

b) Workmen should be medically examined before they are selected.

c) Working time, rest intervals and time and rate of decompression must be carefully regulated when the pressure exceeds  $0.7 \text{ kg/cm}^2$  above atmospheric pressure.

d) Medical arrangements under a medical officer specially trained in caisson disease must be ensured when the working pressure is more than  $1.75 \text{ kg/cm}^2$  above atmosphere and there must be a medical lock.



e) The rate of decompression specified should be followed. Working above a pressure of  $3.5 \text{ kg/cm}^2$  above atmospheric pressure is not allowed except in emergency.

f) The steining concrete for wells to be sunk using pneumatic caissons should be as dense as possible to reduce the pore pressure caused by air under pressure trying to escape through fine pores in concrete.

g) The joints should be made as air tight as possible to prevent escape of air. Water proof cement plastering can be resorted to on the inside face of steining.

#### **427. Founding the well**

##### **1. Settling the well by blasting :**

After loading the well as specified a small charge of one or two gelignite sticks of 50 gm each is exploded at the centre of the well at the level of straight portion of cutting edge. The well should not go down by more than 25mm. If it goes down, the necessity of further sinking should be examined.

##### **2. Dressing the bottom of the well :**

a) As far as possible, the well shall be evenly seated on sound rock devoid of fissures, cavities, etc.

b) One or more cylindrical holes may be made in the base to give good anchorage to the well. (Annexure 4/20 a). Alternatively anchorage can be provided by the rock itself which is allowed to remain projecting at the centre. (Annexure 4/20 b).

c) In shallow wells and wells resting on rock a few holes may be drilled and MS dowels fixed in them for providing a good bond between the base rock and the bottom plug.

d) In case of sand overlaying steeply sloping rocky base below, it is preferable to bench the rock and take the well down to have a proper base. Where this is not feasible, a number of small wells or piles are sunk or driven through the sand till they penetrate into the base rock (Annexure 4/20 c & d)

**428. Bottom plugging of the well**

Bottom plugging can be started immediately after the final sinking and dressing up of the bottom. Placing of concrete in plug can be perfectly done in dry condition or under compressed air. In either case the concrete is taken down in buckets or skip boxes whose bottom can be opened and closed by operating a wire rope from the winch. Another alternative is to place concrete through a tremie. When ingress of water is too heavy for pumping, concreting should be done first under dry condition (filled in gunny bags) all round below the cutting edge for plugging the water coming in, after which dewatering can be done and plug concrete placed in the middle.

**429. Sand hearting**

Forty eight hours after the completion of the concreting of the bottom plug, the well should be filled up with clean sand or sand and shingle or dredged sand not mixed with clay upto 1.5 to 1.75 m below the top of the well. It would be desirable to flood the sand with water for proper consolidation and then pump out the surplus water from the top.

**430. Construction of the top plug**

The construction of the top plug should be started only after the sand filling has settled thoroughly and tested by ramming. A top plug of 1.5 m to 1.75 m in thickness is usually cast with M-10 grade concrete to provide a good base for the well cap (also called entablature) (Annexure 4/21).

**431. Setting out of the piers on the top of well**

The centre line of the bridge as also of the well should be marked on the top plug of the well. Any shifting of the well should thus be ascertained and the capping slab built on the centre line of the bridge.

**432. Construction of well cap (Entablature)**

Before casting the well cap, its centre is adjusted to coincide with the correct centre of the pier and not of the well. The reinforcement from the well steining should be extended into the capping slab for a distance equal to the bond length. The bottom of the well cap is kept about 15 cm above the low water level for convenience of construction. The work on the pier can be started after 48 hours of casting the well cap.



## **CHAPTER - V**

### **REHABILITATION OF BRIDGES**

**501. Bridges may require rehabilitation on account of various reasons as under**

- i) Physical distress,
- ii) Vulnerability on hydrological considerations,
- iii) Use of obsolete/ non standard materials such as
  - a) Early steel girders;
  - b) Laterite stones;
  - c) Cast iron screw piles;
  - d) Corrugated steel pipes (ARMCO pipes)
  - e) Rail or timber tops and stone slabs; and
  - f) Earthenware pipes.

**502.** In case of introduction of new type of locomotives, rolling stock and other train compositions with increased loads (vertical and longitudinal) special strengthening measures may be required as per relevant code provisions and guide lines.

**503.** A distressed bridge is one which shows any physical sign of deterioration of its physical condition, indicating the need for rehabilitation through special repairs, strengthening or rebuilding (including replacement of girders).

N.B. This definition does not include those bridges considered vulnerable due to hydrological factors.

**504. Classification of a bridge as “Distressed”**

1. When in the course of inspection of bridge, defects are noticed, the inspecting official should examine the bridge thoroughly.

2. Based on the detailed inspection, the inspecting official may impose a suitable speed restriction as appropriate. The inspecting official may suspend traffic if the bridge is considered unsafe; restoration of traffic shall either be after a further detailed examination or after adequate relieving measures are undertaken.

3. If cracks have been detected, tell-tales should be fixed. All defects should be recorded, sketches prepared and a detailed report sent to the Divisional Office.

4. The bridge may then be classified as “Distressed” by the Senior Divisional Engineer/Divisional Engineer after a personal inspection. A detailed report should be sent to Headquarters office & RDSO with complete data about the bridge including its completion drawings.

5. Classification of distressed bridges :

Category-I: Those requiring rehabilitation to be done immediately, say within a year’s time.

Category-II: Those requiring to be kept under observation and to be taken up for rehabilitation on a programmed basis.

### **505. Imposition of speed restriction**

All distressed bridges may not require speed restriction. It is not possible to lay down definite guidelines for imposing speed restrictions on distressed bridges . Each case has to be judged and decided on its merits by the inspecting officer, keeping in view the nature and severity of distress. However, for general guidance, speed restrictions upto maximum of 15 kmph is suggested for distressed bridges on Group I and 25 kmph to 50 kmph for distressed bridges in Group-II, The Groups being defined as under:

#### **Group I**

Where the signs of distress are:

1. Settlement of foundations,
2. Tilted piers and abutments,
3. Deep scour around piers/ abutments,
4. Shaken/ displaced/ cracked bed blocks,
5. Cracks or any other distress in bearings,
6. Wide cracks in abutments/piers,
7. Diagonal cracks in arches,
8. Transverse cracks in arches,
9. Distortion of arch,
10. Displacement of brick/stone from arch ring,

11. Crushing of masonry,
12. Progressive loss in camber of Prestressed concrete/ steel girders,
13. Wide cracks in Reinforced Cement Concrete/ Prestressed concrete members.
14. Cracks/ heavy corrosion in load bearing members of steel girders.
15. Weak/ corroded/ cracked piles particularly cast iron screw piles.
16. Snapping of rivets.

### **GROUP II**

Where the signs of distress are:

1. Cracks in return walls/ wing walls ,
2. Slight tilting/ bulging of abutments,
3. Leaning / bulging of masonry in return walls/wing walls,
4. Perceivable deterioration of stone/ brick masonry.
5. Wide longitudinal cracks in arches, abutments and piers,
6. Cracks/ lean/ bulge in parapet walls of an arch,
7. Bulging or separation of spandrel from arch barrel,
8. Spalling of concrete in beams and slabs,
9. Loose rivets above 20% at any joint.
10. Observations of any excessive vibration in part of the bridge structure.

#### **506. List of Distressed Bridges (LDB)**

Each Divisional office should maintain the details of the distressed bridges as per the following proforma.

The list should be reviewed at the end of every year and necessary additions/alterations made. Once the rehabilitation of a bridge is completed, It should be deleted from the list. Any addition to the list should be made after personal approval by the Divisional/ Sr. Divisional Engineer.

PROFORMA

DIVISION :

Section	Km	Bridge No.	Details of Bridge including year of construction	Particulars of distress (sketches to be enclosed if necessary - Ref. Para 505)	Probable cause of distress	Any speed restrictions imposed
1	2	3	4	5	6	7

Remedial measure proposed	Works Programme Item No. in which rehabilitation has been approved.	Approximate cost	Date of completion of rehabilitation & removal from LDB.	Remarks
8	9	10	11	12

**507. Distressed Bridge Diagram**

The Railways should maintain a diagram of distressed bridges containing relevant information, as per Annexure 5/1.

**508. Priority for rehabilitation of distressed bridges**

1. The Divisional / Senior Divisional Engineer, while including a bridge in the distressed bridge list, should also indicate the priority classification depending on nature and severity of distress, as detailed below :

- i) Category I should include those bridges where the distress is such that the rehabilitation work is required to be taken up immediately.
- ii) Category II should include all those bridges which do not fall in Category I. They may be taken up for rehabilitation on a programmed basis.

2. Some Bridges may have to be kept under observation after minor attention like grouting with provision of tell tales. During the period of observation, if it is found that the defects reappear, the bridge may be included in category I or II, as the case may be.

**509. Special inspection of distressed bridges shall be carried out as under**

Category	Inspected by	Periodicity
I.	Inspector (concerned) Asst. Engineer / Asst. Bridge Engineer Divisional Engineer / Sr. Divisional Engineer	Once in a month Once in two months  Once in three months
II.	Inspector (Concerned) Asstt. Engineer / Asstt. Bridge Engineer Divisional Engineer / Sr. Divisional Engineer	Once in three months Once in six months  Once a year

Concerned S.A.G. Officers may inspect these bridges as considered necessary or if referred to by the Division.

**510. Site Data**

After collecting necessary site details, plans for rehabilitation including temporary measures shall be prepared in the Divisional Office and got approved by Head quarters Office.

The engineer-in-charge of the work shall be responsible for the safety of all temporary works during the rehabilitation of any bridge in one or more stages with or without diversion.

**511. Execution of rehabilitation works**

Typical methods generally adopted for rebuilding / rehabilitating / strengthening of bridges are briefly described below except for regirdering , which is dealt with in detail in Chapter VI. Any other method to suit site conditions may also be adopted.

**512. Strengthening of foundations**

1. Replacement of cast iron screw piles:

A new set of substructure on groups of bored piles in between the old ones may be constructed. The old girders may be shifted on to the new substructure, abandoning the old one. (Annexure 5/2). When the head room is restricted, for making bored piles, well foundations can be constructed. Alternatively the new sub-structure and foundations can be constructed with the help of diversion.

## 2. Settlement of foundation in piers / abutments.

Whenever settlement is noticed in piers and abutments, levels of the bed block should be recorded periodically with reference to a fixed datum. The rail level should be maintained by making up with packing plates or steel stools, as necessary.

## 3. Excessive scour around piers/abutments:

a) This is a common occurrence in flowing rivers. Dumping of boulders and grouting the void space between boulders is normally resorted to. In some cases sheet piling or micropiling can be done concentric to the piers and the intermediate space filled with concrete / boulders. It should be ensured that the water way is not restricted.

b) Provision of adequate flooring with drop/curtain walls of sufficient depth may be provided in the case of scour in shallow foundations.

## 513. Strengthening / rebuilding of substructures

a) Bed blocks get shaken up causing cracks in masonry below bed blocks. Fine and medium sized cracks which are not yet deep may be grouted and sealed using epoxy resin through pressure injection method. For details regarding methods of pressure injection with epoxy resin reference may be made to para 209. The work should be carried out as per the specifications of the reputed product manufacturer. If the cracks are deep, cement grouting may be resorted to.

(b) Where the existing structure is fairly sound and does not show any sign of distress but is of inadequate section or has extensive surface weathering, jacketing with cement concrete with minimum thickness of 150mm, suitably dowelled into the old masonry/concrete may be done. The jacketing, to be effective, must be taken right upto the foundation and integrated at foundation level with the foundations. The dowel bars consisting of 20mm diameter MS deformed bar (HYSD bars) hooked at the exposed end or MS tie bar flats (45 x 10mm size) with the ends split, may be fixed into old masonry/concrete. These dowels should be taken down to a depth of not less than 200mm inside the masonry/concrete. The spacing of dowels should not be more than 450mm horizontally and vertically. Dowels should be provided in staggered manner. (Annexure-5/3a)



Before jacketting is taken up, existing cracks should be thoroughly grouted. It should also be ensured that the resulting reduction of waterway due to jacketting is within permissible limit. The face of the existing masonry or the concrete should be thoroughly cleaned free of all dirt. In case of concrete, the smooth surface should first be made rough. Before laying the new concrete, neat cement grout should be applied uniformly over the face of the old masonry/concrete. The new concrete layer should be of 1:2:4 mix although the maximum size of the aggregate may go upto 40mm. A mat of steel reinforcement with a minimum of 10mm bars spaced at 200mm horizontally and vertically may be provided as distribution reinforcement.

The following precautions should be taken while carrying out the jacketting works :

- i) Foundation shall be exposed for only limited width at a time so as to avoid endangering the safety of the structure.
- ii) Pumping of water from foundation should be avoided as far as possible, as it may endanger the safety of the structure.
- iii) Holes for dowels should be drilled and not made by pavement breakers.
- iv) The work of jacketting should be done under suitable speed restriction. Depending upon location, extent of exposure, type of soil etc., speed restriction may be as under:

Jacketting below bed level	15 km/h to 30 km/h depending on the extent of exposure, type of soil etc.
Jacketting from bed level to top of sub-structure	30 km/h to 50 km/h depending on condition of masonry.

The above speed restrictions may be relaxed after the completion of work as per the following guidelines, if jacketting is carried out using ordinary Portland cement conforming to IS: 269 :

- i) 50 km/h after 7 days of last concreting;
- ii) 75 km/h after 14 days of last concreting; and
- iii) Normal sectional speed after 28 days of last concreting.

To reduce the duration of speed restriction, rapid hardening cement to IS: 8041 may be used.

c) For bulging / leaning of abutments, after checking the adequacy of the section, action is taken to strengthen the abutment by jacketing the front face (Annexure 5 /3b). In case the earth in the rear of the abutment can be opened, strengthening in the rear may also be adopted. Strengthening should be carried out from foundation level.

d) The pressure on the abutment can be relieved by suitably designed approach slabs or by provision of adequate granular backfill and proper drainage.

#### **514. Shaken/ displaced/ cracked bed blocks**

1. Where the bed blocks are shaken or displaced and where masonry below has developed cracks, bed blocks may be encased in RCC and the affected portion to the masonry in piers below jacketed (Annexure 5/4a).

2. Individual bed blocks which are cracked can be replaced with through RCC bed blocks. If it is possible to impose temporary speed restriction, the work can be done in-situ, with reinforcement bars and steel stools (Annexure 5/4b). Alternatively RCC bed blocks can be precast and fixed to the masonry using epoxy resin mortar.

3. Use of epoxy resin mortar for bonding precast RCC bed blocks to masonry substructures has been found to be very advantageous as the compound develops full strength within few hours. The epoxy mortar normally consists of resin, hardener and filler. The curing reaction is initiated as soon as the resin and hardener are mixed. The surface on which epoxy mortar is to be applied must be even, dry, free from dust and loose particles. It is important to follow the manufacturer's specifications for mix proportions, application procedures, temperature and pot life (time during which mortar remains workable). For best results use of polythene vessels, hand gloves and safety glasses is recommended while working with epoxy compounds.

#### **515. Distressed arch bridges**

1) In case of cracks in arches, pressure grouting with cement mortar at a pressure 4 to 6 kg/cm<sup>2</sup> is generally quite effective.

2) If pressure grouting is not effective, one of the following alternative methods may be adopted:

a) Construction of a suitably designed box culvert under the arch and filling the intermediate space between the arch and the box with lean cement concrete (Annexure 5/5a).

This method may be adopted when the HFL is not high.

b) Construction of a box culvert abutting one of the abutment dismantling the other abutment, when the HFL is high or the waterway is inadequate (Annexure-5/5b).

c) Closed ring jacketting, where a slight reduction in waterway is permissible (Annexure 5/5c). Specially designed folded plate design can be successfully adopted in the above case (Annexure 5/5f).

d) Jacketting below intrados: For strengthening of distressed arches, jacketting below intrados is preferable, if the resultant reduction in waterway is permissible. In such cases, new arches should be designed as under:

i) to take the entire load by itself where the existing arch has transverse crack(s).

ii) to take the entire load by composite action with the existing arch ring, where the existing crack(s) are all longitudinal or there are no signs of distress in the existing arch and if effective bond could be ensured between the new and old arch ring.

e) Jacketting above extrados: In some special cases, external (extrados) jacketting of the arch is resorted to, after relieving the arch by temporary girders. In such cases, the new arch ring should be designed to take the entire loads i.e. dead and live loads etc.

f) Where the HFL is high, it may be advantageous to convert the arch bridge into a slab top by suitable raising and strengthening the masonry of the piers/abutments and using pre-cast reinforced cement concrete/prestressed concrete slabs over them. Alternatively arch relieving girders may be used. The arches can be retained where there is adequate cushion above them. In other cases, the arch may be dismantled, either during a line block or under temporary relieving arrangement but before placing of the slab/girder. (Annexure 5/5d and e).

3) In the case of strengthening (i.e. by jacketing) of abutments and piers of arch bridges, the design should always be on the basis of composite action of the new material acting along with the existing one. It should, however, be ensured that a proper bond is established between the existing masonry and new material by suitable means such as dowels and post grouting through grout holes to be left while casting the jacket.

4) In all cases of cracked masonry, whether in arches or in abutments and piers, all the cracks should be plugged by pressure grouting before the additional material (jacket) is provided.

5) In all cases of jacketing, precautions mentioned in para 513 (b) should be followed. In cases of jacketing below intrados, the space in between the new arch ring and the existing arch ring should be pressure grouted, for which hole should be provided in new arch ring.

6) Jacketing works should be done under suitable speed restriction. Depending upon location, extent of exposure, type of soil etc., speed restriction may be as under:

i)	Jacketing below bed level.	15 km/h to 30 km/h depending on the extent of exposure, type of soil etc.
ii)	Jacketing from bed level to springing level.	30 km/h to 50 km/h depending on condition of masonry.
iii)	Jacketing of arch ring when designed for the full design load.	30 km/h to 50 km/h depending on the condition of arch ring and cushion.
iv)	Jacketing of arch ring when designed by taking composite action with existing arch.	15 km/h.

The above speed restrictions may be relaxed after the completion of work as per the following guidelines, if jacketing is carried out using ordinary Portland cement conforming to IS:269:

- i) 50 km/h after 7 days of last concreting;
- ii) 75 km/h after 14 days of last concreting; and

- iii) Normal sectional speed after 28 days of last concreting.

To reduce the duration of speed restriction, rapid hardening cement to IS : 8041 may be used.

### 516. Replacement of non standard girders

1. When HFL is not high :

Girders may be replaced adopting any of the following methods :

- a) Using precast Reinforced Cement Concrete / Prestressed concrete slabs with or without replacing bed blocks ;
- b) Construction of a pipe culvert with one or more rows of pipes on a concrete bedding duly filling the portion above.
- c) Constructing a Reinforced Cement Concrete box inside each span duly filling the portion above the box.

2. When the HFL is high , one of the following methods may be adopted.

- i) When the track can be regraded the girders can be replaced by RCC slabs suitably regrading the approaches.

- ii) When the track cannot be regraded there are two options that can be adopted.

- a) Where sufficient clearance is not available below the bottom of the girder a deep precast bed block integral with slab of less than standard thickness (called "Drop") may be used (Annexure 5/6a).

- b) Where sufficient clearance is available below the bottom of the girder specially designed RCC slab with tapered ends (fish belly type) may be used. (Annexure 5/6b).

### 517. Replacement of pipe culverts

1. Damaged pipe culverts with ARMCO pipes may be replaced by

- i) Pipes of standard designs under temporary relieving arrangement.
- ii) Pushing of pipes of standard designs at a new location by the side, where suitable cushion is available.

- iii) A reinforced cement concrete box either cast insitu under temporary relieving arrangement or cast outside in sections and slewed into final position or by the box pushing method as may be most appropriate (Annexure 5/7).

2. Suitable speed restriction should be imposed during execution of the work.

### **518. Distress in parapets**

Bulging / leaning of parapets is a common feature in any existing arch bridge. If possible the track may be lowered to reduce the side thrust on the parapet wall. The parapets may be held in vertical position by the use of rails placed parallel to track abutting the parapet wall from outside and held in position by transverse rods with check nuts (Annexure 5/8). In such a case, clean ballast and adequate drainage must be ensured.

### **519. Replacement of small opening**

Small openings i.e. rail cluster, non standard girders, timber tops, stone slabs, etc. may be replaced by suitably designed ballastless slabs.

### **520. Distress in superstructure**

#### 1. Distress in slabs :

Where reinforced cement concrete slabs are cracked and cannot be repaired by grouting they should be replaced by slabs.

#### 2. Distress in girders :

a) If corrosion is heavy, regirdering should be proposed.

b) If there are many loose rivets, turned bolts should be provided and speed restriction imposed as necessary. The turn bolts should be replaced by rivets before relaxing the speed restriction.

c) In the case of distress in prestressed concrete and reinforced cement concrete girders, the cause should be thoroughly investigated. External prestressing, epoxy grouting depending on the nature of distress may be adopted. For details, reference may be made to Manual of Inspection and Maintenance of Concrete Bridges, 1990:" issued by RDSO and other specialist literature on the subject.

### **521. Replacement of Meter Gauge Bridges**

Whenever MG bridges are rebuilt the substructure and super structure shall be built to BG standards.



## CHAPTER - VI

# CONSTRUCTION OF SUBSTRUCTURE AND SUPERSTRUCTURE INCLUDING ERECTION OF GIRDERS

## PART A - CONSTRUCTION OF SUBSTRUCTURE

### 601. General

The function of piers and abutments is to transmit the live load and the dead load of the superstructure to the foundations. The details of the loading to be considered in the design of substructure are contained in the IRS Bridge Substructure Code and Bridge Rules and include, inter alia, impact effect of the live load and the longitudinal forces exerted by it, transverse loading caused by wind action on the substructure and the live load and due to the pressure exerted by back fill etc.

### 602. Importance of aesthetics in Construction

1. Apart from functional requirements, aesthetics merits serious consideration as the piers and abutments are exposed to view. In combination with the substructure, the entire bridge should provide a pleasing view and harmony with the surroundings. Thus a design which is appropriate for viaduct may be out of place in a built up area.

2. Reinforced and prestressed concrete permit adoption of piers and abutments in various forms such as A,Y, etc.

3. Though the main dimensions and choice of spans are largely determined by functional and economic considerations, proper proportioning of the various elements of a bridge (i.e. height, width and length of piers, length of spans etc.) is also important. Variations within reasonable limits should be allowed for in design to enable proper proportioning of the bridge.

4. The final shape of a structure should also highlight the special qualities of the materials used for construction. For example, stone masonry generally goes well with an arch bridge, while the use of prestressed concrete girders with a flat decking and tall or thin piers. A bridge should not intrude into the environment and look heavy.

5. While constructing road over bridges or flyovers in heavily built up areas, the aim should be to avoid too many piers in the middle so that a road user can have a clear unobstructed view. In viaducts, it is advisable to have slender and tall piers.

### **603. Material of construction**

1. For stone masonry, the proportion of cement mortar used should be minimum 1: 4.

2. When mass cement concrete is used the mix shall be minimum M.20 grade. It shall be preferably design mix, using 40 mm aggregate.

3. Reinforced cement concrete, used in the form of thin piers or as a framed structure, can be adopted for viaducts, fly overs and road over bridges. Cellular piers are suitable if the heights are considerable. For reinforced cement concrete structure, the mix concrete shall be minimum M-25 grade.

4. Prestressed cement concrete can be used for all piers of viaducts. The mix to be adopted should be according to the design requirements.

### **604. Piers, abutments, wing walls and approach slabs**

1. Piers, abutments, and wing walls :

a) The size of piers and abutments depends on the construction materials used.

b) Masonry piers are provided with a batter varying from 1 in 24 to 1 in 12. Their width at the top is determined keeping the minimum space required for seating of the bearings of girders as also to provide sufficient distance on the outside of the bearings to resist diagonal shearing.

c) For masonry abutments, a front batter of 1 in 16 to 1 in 10 is used: a flatter slope or steppings are provided in the rear as per design requirements.

d) When piers are reinforced cement concrete, typical sections used are shown in Annexure 6/1.



## 2. Wing Walls

a) The abutments can either be of the conventional type with the front face exposed or of the buried type when waterway requirement is not the main consideration.

b) In the former case, wing walls are necessary to retain the slopes of the approach banks. Wing walls can be of the splayed, straight, square or 'box' type (Annexure 6/2). Butt joints should be provided between wing walls and abutment, wing walls and return walls and for the various tracks, when the bridge is for more than one track to cater for differential settlement in case of poor soils.

c) Wing and return walls also require provisions of weep holes as in abutments.

## 3. Approach Slabs :

In order to reduce impact effect and to obtain improved running, properly designed approach slabs may be provided on both the approaches of non-ballasted deck bridges having spans of 12.2 m or more. One end of the approach slab may be supported on the abutment and other end on the formation. Length of the approach slab shall be minimum 4 m.

### 605. Construction aspects - General

1. When the ground is dry, construction of piers and abutments will not require any special arrangement. For their construction in water either coffer dams or temporary sheet piles may be used to divert the water as indicated in Para 404.

2. Construction of tall reinforced concrete piers can be expeditiously done with the slip form construction.

3. In abutments, weep holes should be provided at vertical intervals of 1 m and horizontal intervals of 1 m in a staggered manner. Behind the abutment and wing walls boulder filling and back fill material should be provided for the full height. The boulder filling should not be less than 600 mm thickness. The back fill material should consist of granular material of GW, GP, SW groups as per IS 1498 and should be free of clay and cement (Annexure 6 / 3).

### **606. Important points in regard to construction of substructure and superstructure**

1. As regards construction in brick and stone masonry, the relevant specification prescribed by the Chief Engineer shall be followed.

2. When concrete is used in construction, the important points to be observed are given in the subsequent paras.

3 i). Concreting shall conform to the requirements specified in IRS Concrete Bridge Code and IS.456.

ii) Proportioning of the concrete mix shall preferably be done by weigh batching.

However, for concrete upto M-20 grade, mixing on equivalent volume basis may be permitted with necessary correction for bulkage. For concrete richer than M-20 proportioning shall be done by weigh batching only.

4. All works in PSC shall be done with weigh batching only.

5. Design of concrete mix shall be in accordance with any of the methods given in the recommended guidelines for concrete mix design, published by the Indian Standards Institution.

6. Ordinary Portland cement conforming to IS 269 shall be used for plain, reinforced and prestressed concrete work. Portland blast furnace cement conforming to IS 455 may also be used for plain and R.C.C. work but not for PSC work. Portland pozzolana cement (IS 1489) shall not be used for PSC and RCC works. It can be used only for foundation concrete and concrete works in Bridge substructure where reinforcement is not provided for structural strength. When Portland pozzolana cement is used it is to be ensured that proper damp curing of concrete is done at least for 14 days and supporting form work is not removed till concrete has attained at least 75% of design strength. High strength ordinary Portland cement conforming to IS 8112 (Grade 43) and IS 12269 (Grade 53) may also be used where required from consideration of mix design.

7. Reinforcement steel shall conform to one of the following specifications :

i. Grade I mild steel & medium tensile steel bars conforming to IS:432 (part-I).

ii. Cold twisted bars conforming to IS : 1786.

iii. Rolled steel made from structural steel conforming to IS: 2062 Grade A and Grade B.

8. The prestressing steel shall be any one of the following:

i) Plain hard drawn steel wire conforming to IS : 1785 (Part I)

ii) High tensile steel bar conforming to IS : 2090 and

iii) Uncoated stress relieved strand conforming to IS : 6006.

9. i) Reinforcement steel shall be free of loose mill scales, loose rust and coats of oil, mud or other material ,while being used.

ii) Cover and spacing of steel shall be uniform and as specified in the drawings.

iii) All ends of binding wires shall be carefully turned inside so that they do not project out of concrete to induce rusting .

iv) Reinforcement steel shall be adequately secured so that it maintains its position during casting and vibration of concrete.

10. Aggregates : Aggregates conforming to IS : 383 shall only be used. They shall be clean. Marine aggregates shall not be used in concrete unless they are thoroughly washed in potable water and sulphur and chlorine content are low. The tests on aggregates shall be done in accordance with IS : 2386 (Part-I) to IS : 2386 (Part VIII)

11. Water used for mixing and curing concrete shall be clean and free from injurious amounts of oil, acids, alkalis, salts, sugar, organic materials or other substances which may be deleterious to concrete or steel. Potable water is generally considered fit for use in concrete. Further details can be seen in IRS Concrete Bridge Code.

12. Form work : Form work requirement shall be as per IRS Concrete Bridge Code including stripping time. In the case of PSC works, support shall not be removed till sufficient prestress has been imparted to the member.

13. Special attention shall be given to curing of concrete in order to ensure maximum durability and minimise cracking. The method of curing shall be as per IRS Concrete Bridge Code.

14. The appropriate value of minimum cement for different exposure conditions and maximum cement content for RCC and PSC works as well as the water cement ratio shall be as per the provisions given in the IRS Concrete Bridge Code. The equipment, material and the proportions of the mix to be used shall be submitted to and approved by the engineer before the work is started.

15. i) While transporting concrete from the mixer to the form work, no segregation shall occur nor should there be any loss of ingredients. Necessary precaution may be taken to ensure this.

ii) The concrete shall be deposited as nearly as practicable in its final position without rehandling. It shall be compacted before setting commences . It shall not be subsequently disturbed. The method shall be such as to avoid segregation. There shall be no displacement of steel or form work while placing concrete.

16. Compaction of concrete: All concrete shall be compacted by vibration. Generally internal vibration shall be used on all sections that are sufficiently large to admit them. The use of mechanical vibrators complying with IS:2505, IS:2506, IS:2514 and IS:4656 for compacting concrete is recommended.

The following techniques shall be followed for vibration:

- i) Vibrators shall be distributed so that the concrete becomes uniformly dense and plastic mass.
- ii) Vibrators shall be used for compaction only and not for moving concrete horizontally along the form.
- iii) For horizontal and vertical operations of vibrators, the spacing of points of vibration shall be such that the zones of influence overlap.

- iv) For concrete deposited in layers, the vibrators shall be inserted vertically and allowed to sink due to its own weight to the bottom of the layer and be slowly withdrawn. For succeeding layer, the vibrator shall penetrate the surface of the previous layer. For further details, IRS Concrete Bridge Code may be referred to.

17. Bearing areas for members shall be finished to true plane so as to give uniform bearing on the entire area. Bearing plane shall be horizontal even for the bridges on grades.

18. In major works, a field laboratory should be set up at the work site which should be equipped with necessary equipments to carry out the various tests on coarse and fine aggregates, cement, water and concrete.

## **PART B - CONSTRUCTION OF SUPERSTRUCTURE**

### **607. Slab Bridges**

Slabs shall preferably be precast in a depot and installed at site; where this is not possible they may be cast in situ. From considerations of economy, PSC slabs may be used for spans larger than 3.05 m.

1. Stagnation of water or retention of water in the body of the ballast over deck bridges leads to severe damage to the decking through percolation of water and consequent corrosion of reinforcement. It is therefore, essential that on deck bridges, water is not allowed to stagnate or retained in the ballast. It is therefore, essential that the ballast is clean and the drainage arrangement of the deck is also free from any obstruction. To ensure this, deep screening of ballast as necessary should be carried out. The drainage arrangement of the deck must be cleaned annually before monsoon.

### **608. Arch Bridges**

1. Work on a single span : The construction is done by providing stagings or temporary support underneath and putting up the arch above. Before taking up the construction of the arch, back filling of abutments must be ensured. After the material of structure completely sets and is able to take the load, the temporary structure is removed.

2. Work on multiple spans:

a) Work can be done simultaneously on a number of spans using more than one set of forms.

b) In this method, due care will have to be taken to see that the horizontal thrust on the pier/abutment is not such that they give way. This can be guarded against by commencing the work on the adjacent span and bridging some load to bear on the pier before the support and the framework used on the previously cast span is removed. A proper sequence of construction of multiple span arch bridge shown in Annexure 6/4 (a).

c) Supporting arrangement for arches: Over dry beds of streams, stagings can be constructed from the bed itself. Due care will have to be taken in supporting the staging columns on bed by giving a suitable timber support to spread the load and to check the stagings at various stages to see that it does not settle under the load when the casting of superstructure is in progress.

d) If the work has to be carried out in flowing water of the river, the staging will have to be supported over shallow thin piles driven in the sand bed for sufficient depth (say 3 to 4m into the soil).

e) In case the height of the pier is considerable as in high viaducts and staging is to be put up from bed, it may be difficult and expensive and alternative methods of supporting the staging from an intermediate level have to be provided. For this purpose, intermediate ribs are provided on piers to support the temporary floor system over which the false work can be put up or props erected from bed.

3. The arch ring or barrel should be cast in segments, the minimum number being two so that the effects of shrinkage can be countered by casting shrinkage keys between them separately. These keys are cast after the major shrinkage in the segments take place. Care should be taken in the sequence of casting segments/units so as to allow for shrinkage and at the same time develop the strength at appropriate location. A suggested sequence is shown in Annexure 6/4 (b)

4. An alternative method of erection evolved after development of pre-casting techniques is by stretching a cable across the span and erecting precast units from either end and staying them with wires till the last units "crown" is laid and it sets. Cables will be released and removed after the arch sets and is able to act monolithically.

### **609. RCC/PSC bridges (Beams with slab)**

1. In case of slab and beam bridges, the easiest method would be to use cribs and supports from below and cast them in situ.

2. The alternative method is to launch and erect a temporary girder supported on the ground or an intermediate projections from the pier. Precast girder can be launched over this. This method can be extended for even larger spans.

### **610. Erection of PSC girders**

1. Erection by use of launching girders:

Fully cast prestressed concrete girders are not launched independently as the cantilevering stress developed is considerable and the design is difficult. In such cases, the method adopted is to first launch a steel or aluminium supporting frame or girder so that it spans over the gap. This is designed to take only one girder at a time. Once the launching of this temporary girder is over, the first main girder is moved over this temporary girder or frame, supported at intervals or pulled across. When the full length of the main girder has come over the launching girder, it is jacked up and temporarily held in position. The launching girder is then side slowed to take the position of the next girder over the span. The main girder launched earlier is then lowered into position with the help of jacks.

The launching girder can be then be moved over the next span. A schematic diagram is shown in Annexure 6/5 (a).

2. Erection of concrete girders with cranes/derrick : If the bed is dry, the girders can be cast on the bed and erected by mobile cranes one on either end or with the help of a suitable derrick in the centre or one derrick each on either end. If the height of the pier is not much and girders are too heavy to be launched by the available crane or derrick,

the girder can be jacked up from either end on temporary rails (which will also be simultaneously built up ) to pier top level and then side slewed in position. The deck slab can be cast subsequently.

In the case of prestressed concrete girders transverse prestressing will also be involved. For this purpose, holes should be left in correct position to form ducting. The diaphragm with necessary ducting should be cast after all the girders are launched correctly and adjusted in position.

Part prestressing is done before individual girders are lifted or launched and remaining cables are tensioned, some before and balance after or all after the deck is cast according to the design. Extreme care has to be exercised in following the sequence that has been given by the designers as any deviation can cause a crack or unwanted lateral deflection in the individual girder.

### 3. Erection by Cantilevering Method :

For very large spans, cantilevering method may be adopted. In this method, the erection starts from the abutment end and the erection of the members ahead is done by using a crane which travels by using the support on the previously erected part structure. Annexure 6 / 5 (b) and 6 / 6 (a)

### 4. Incremental launching method :

The method is basically a cantilever erection method for PSC bridges. By adopting this method, it is possible to effect economy in construction and ensure the quality due to adoption of factory type production and also ensure quick erection. This method is particularly suitable for launching continuous girders due to site requirements.

Incremental launching is a highly mechanised bridge girder erection method. Basically, it consists of manufacturing a prestressed concrete bridge girder segment by segment in a prefabrication area behind one of the abutments. Each new segment is concreted directly against the preceding one and after it has hardened and stressed, the structure is jacked forward by the length of one segment. A steel launching nose is attached in front, to facilitate launching. Gradually the bridge unit is pushed out over the intermediate piers (Annexure 6/6 (b)).



In this method the span and depth configuration is to be suitably chosen and the cross section has to be of box or a double T section. The piers should resist forces during launching in excess of those due in the permanent structure. Design has to take into consideration in advance the use of this method as the prestressing section requirements have to suitably allow for the same. The depth of the box girder in relation to the span should be able to cater for the reversal of stress and for shear in the webs without undue congestion of reinforcement and prestressing tendons.

The temporary support if used for launching need to stay in place until the bridge launching process has been completed and the final prestressing force applied.

#### **611. Important points to be borne in mind in the construction of PSC girders**

1. i) The handling and erection stress.
  - ii) Accessibility of every part of the structure for close inspection.
  - iii) The design of the end block and bearings should permit periodical inspection and servicing of the bearings.
2. Provision shall be made to cater for an additional prestressing forces of 15% of the design prestressing force, for easy installation of prestressing steel at a later date.
3. Admixtures/plasticizers of approved type only should be used.
4. Minimum grade of concrete for PSC work shall be M/35.
5. In all methods of tensioning, the stress induced in the tendons shall be determined by measurement of elongation and also independently by direct measurement of force using a pressure gauge or other means. The two values shall be comparable to each other and the theoretical values within a tolerance of 5%. Calculations for elongations and gauge readings must include appropriate allowances for friction, strand wire slippage and other factors as applicable. Breakage of wires in any one prestressed concrete member shall not exceed 2.5% during tensioning. Wire breakage after anchorage, irrespective of percentage, shall not be condoned without special investigations.

6. Prior to stressing of strands, bottom forms should be kept clean and accuracy of alignment ensured. Form surfaces to be in contact with concrete must be treated with effective release agent. Special care must be exercised to prevent contamination of strands from release agents, grease or other coatings.

7. Cables shall not be left unstressed in ducts for long duration and hence threading of cables in ducts shall be done just prior to stressing.

The initial stress due to prestressing in the cable shall not exceed 80% of UTS of the cable.

8. Post tensioning systems shall be installed in accordance with the manufacturer's directions and proven procedures. Manufactures's recommendations regarding end block details and special arrangements in anchorage zones applicable to their particular system should be observed.

9. Details and positions of ducts : Ferrous metal is recommended for duct material. Aluminium should not be used. Metal ducts must be such that destructive galvanic action on duct and tendon will not occur.

10. As the alignment and position of ducts within the member is critical, short kinks and wobbles shall be avoided. The trajectory of ducts shall not depart from the curve of straight lines shown in the drawing by more than 1 in 240. The cable position shall not deviate by more than 5 mm from the designed trajectory vertically. The area and alignment of ducts shall be such that tendons are free to move within them and there shall be sufficient area left out to permit free passage of grout.

11. Any slack in the prestressing tendon shall first be taken up by applying a small tension. For arriving at the extent of correction and the actual elongation, the procedure given in IS : 1343 shall be followed. The rate of application of load shall be in accordance with manufacturer's recommended procedure for post tensioning.

Slip must be measured at each end and the extension for the total length.

12. Anchorage : Anchorage devices for all post tensioning systems must be aligned with the direction of the axis of tendons at the point of attachment. Concrete surface, against which the anchorage devices bear must be normal to this line of direction. Accurate measurement of anchorage losses due to slippage or other causes shall be made and compared with the assumed losses shown in the post tensioning schedule and when necessary adjustments or corrections shall be made in the operation.

13. The stressed cables shall be grouted immediately after the prestressing operation for the girder is completed. To avoid possibility of part of the sheathing getting clogged by the over laying concrete, it shall be ensured that the cables move freely inside the sheath during and also after concreting. All precautions shall be taken to ensure that the sheathings do not get contaminated with deleterious chemicals, salts, etc. during the manufacture, storage and installation of the same and they are watertight.

14. Protection to prestressing steel : All prestressing steel shall be free of deleterious materials such as grease, oil, wax, dirt, paint, loose rust, or other similar contaminants that would reduce bond between steel and concrete. Prestressing steel shall not be contaminated with form release agents used on forms or beds. High strength steel is to stored under cover to prevent `corrosion. Prestressing steel with deeply etched or pitted surface will not be permitted for use in PSC work. However, a light surface rust strongly adhering to the steel is acceptable. Strand surface shall always be inspected prior to placement of concrete and contaminated ones shall be cleaned with an effective solvent.

15. Safety : Large tensioning forces which are necessary to all prestressing operations make such construction very hazardous. It should be ensured that good safety practices are established and that each employee complies with the same.

16. Tensioning of the prestressing steel shall not be commenced until all the necessary tests of the concrete cubes manufactured of the same concrete and cured under the same conditions have been carried out and the results found satisfactory.

**612. Quality control in prestressed concrete works**

1. Quality control : Ensuring the required standard of quality for prestressed members is a must. The most important factors to be ensured in this connection are :

- a) Testing and inspection of the various materials selected for use.
- b) Clear and complete detailed working drawings.
- c) Accurate stressing procedures.
- d) Proper control of dimensions and tolerances.
- e) Proper location of anchors.
- f) Proper proportioning and adequate mixing of concrete
- g) Proper handling, placing and consolidation of concrete
- h) Proper curing
- i) Proper handling, storing, transporting and erection of members.
- j) Thorough documentation

2. Cracking of concrete :

a) Some hair line cracks which may form during casting or curing, if superficial, have no detrimental effect on the structural capacity of member.

However to prevent any possible corrosion through hair cracks and deterioration of concrete suitable surface treatment shall be given to the exposed surface. The following precautions shall be taken to avoid cracking.

- i) Ensure proper curing
- ii) Release side forms as soon as practicable.
- iii) Use hoop steel around tendons near ends of beams.
- iv) Handle only from designated pick up points.
- v) Take adequate care during storage, transportation and erection.

3. Camber :

Camber is the upward deflection which occurs in prestressed concrete flexure members due to eccentricity of prestressing forces. It does not include dimensional inaccuracies due to errors in manufacture, improper bearings or other deficiencies of construction.

The anticipated camber due to prestressing shall be computed and shown in the detailed working drawings. Actual camber shall be measured and compared with the computed values.

4. Dimensional tolerances may be permitted as provided in IRS Concrete Bridge Code and any other relevant literature.

## **PART C - FABRICATION AND ERECTION OF STEEL GIRDERS**

### **613. Preparation for fabrication**

The fabrication shall be as per detailed approved drawings and shall conform to IRS B/1 specifications. The fabrication shop should make out further detailed drawings for the templating and preparation of jigs. For this purpose the girder inter section lines are marked over a specially prepared floor, preferably laid with steel plate surface. The layout of members and joints are set out on this and the holes correctly marked after which templates for various individual members are made out. The templates are generally made with sufficiently thick galvanised iron sheets.

If the work is of large and repetitive nature, jigs should be prepared (with reference to the templates) by the fabricators. These jigs are used for marking, cutting and drilling holes. The hole position on the jigs will be correctly drilled and provided with proper bushes. While drilling holes through a set of plates, a number of plates which can be taken by the drill will be assembled together and then through drilling done so that drilling is uniform and spacings are correct.

### **614. Trial Shop Erection**

The first span must be completely erected in the shop (in bolted position) for ensuring the accuracy of the templates, interchangeability of members, fairness of holes at joints and checking camber achieved. The dismantled components are inspected, painted and shipping marks stencilled before despatch to site.

### **615. Preparation of surface**

The surface of steel work should be carefully prepared by removing mill scales, rust, grease etc. using wire brushes, sand or grit blasting as required.

The surfaces and locations which will be in permanent contact after assembly by riveting should be given a heavy coat of red lead paint to IS : 102.

### **616. Field Erection**

1. General : Plate girders and open web girders are fabricated in convenient lengths to suit transportation and availability of plate lengths. In general the length is restricted to about 12m so as to facilitate transport in single lengths.

2. Erection of plate girders : There is no camber provided in the plate girder and they are erected on a level ground over the platform made up of compacted earth or concrete base. Over this, sleeper or timber pickings at suitable intervals are laid for laying the main members for assembly. After they are laid, levelled and aligned, splicing plates are fixed. The bracings are connected and the joints first provided with bolts. Joint holes are partially filled with drifts for bringing them into proper alignment. 40% of the holes are covered with drifts, after which the bolts are removed one by one and the rivetting done.

3. Erection of triangulated girders :

In the case of triangulated girders, a uniform level platform has to be prepared first on a firm ground. The platform should be such that the load transmitted at panel point can be properly transmitted without any settlement occurring. Over this platform at panel points, timber packings are placed over which camber jacks are erected. These jacks are all run up almost to full height and their tops are first levelled. The bottom boom is then erected on these jacks, aligned and connections made. Floor members are then erected. The joints are made by filling not less than 50 percent of the holes. The camber jacks are then lowered by necessary amounts, keeping the central jack in the original position, so that the resultant bottom profile of girder takes the shape conforming to the theoretical camber. After this, using derricks or crane, the vertical members are erected and then the diagonals. The top boom members are erected, starting from the centre. While erecting the top boom members, it should be noted that a considerable amount of drifting will have to be done.

4. Upto a maximum of 40 percent of the holes of each member of the joint can be filled with drifts and balance with bolts. The holes are generally kept 1.5mm larger than the rivet shanks so that the black bolts can be easily inserted for holding the members without any damage being caused to the bolts. After all the joints are thus properly connected, bolts should be replaced one by one with rivets and then the drifts replaced by rivets. Care should be exercised while lifting and slinging the members during erection so as to cause no permanent set in them. The rivets should be heated to the specified heat for the full length of the shank before being transported to the location of joints and inserted in the holes. Mobile heating furnaces are set up close to the joints where rivets are used. The initial heat of the rivet, particularly the long ones which are to be conveyed over some distance, should be a little more than the required heat so that the required specified heat is available at the time it is being inserted into the hole. After the insertion into the hole, the rivets are firmly backed at the head with a dolly and the other end of the rivet is driven down by using the rivetting hammer so that the shank expands and fills the entire rivet hole and proper snap head is left on hammering end also. Where it is not possible to back up with a proper dolly, double gunny can be done. The driven rivets after they are cooled should be cent per cent checked for their firmness.

5. Adoption of riveted fabrication for plate/composite girders should not be done without prior approval of Board.

### **617. Welded Girders**

All fillet and butt welds for the fabrication of welded I - Section, are required to be made by submerged arc welding process, either fully automatic or semi automatic type. The entire length of fillet welds is checked by NDT methods and all the butt welds in flanges and web are required to be radiographed and cleared. In the case of composite girders, the top flange plate with channel shear connectors, welded in staggered arrangement, should be made first, before the I - section is made. Suitable jigs and fixtures are needed for fabricating the members by welding, to reduce the extent of warping and distortion.

Site welding is generally prohibited. However, it can be permitted by the Chief Bridge Engineer where unavoidable and is confined to connections having low stresses, secondary members, bracings etc. The suitability of parent metal to take welding, should, however, be tested first.

### **618. Painting of New Girders**

The Schedule of painting as detailed in IRS B-1 specification shall be adopted.

### **619. Choice of a suitable method of girder erection**

1. Several methods are available for girder erection. The following factors generally influence the suitability of a particular erection method:

- a) Particulars of Bridge and spans.
  - i) Length, width, height, & weight of girder.
  - ii) Number and type of spans.
  - iii) Height and width of piers and abutments
  - iv) Skew or square span.
- b) Site conditions.
  - i) Type of gap, wet, dry or partly dry.
  - ii) Height of gap.
  - iii) Depth of water, velocity and liability of river to spates or floods.
  - iv) Condition of approaches- high or low banks or cuttings.
- c) Access to site.
  - i) Road, rail or water access.
- d) Availability of bridging equipment and bridging materials.

2. Some of the commonly used erection and launching methods are described briefly in paras 621 to 629.

### **620. Preliminary arrangements before girder erection**

1. Collection of site particulars:

Site conditions should be carefully studied by visiting the site and noting all the relevant facts before preparing erection schemes. Cross sections of the rivers should be taken and HFL, LWL, the bed level



and bank level should be plotted. Before embarking on preparation of the scheme, a through knowledge of the hydrographs of the river is essential. From the past recorded hydrographs of the river, a curve must be drawn showing the maximum levels during any year on any date; thus the Engineer will know by what time he must complete certain jobs and which of the jobs can be tackled later. When crossing rivers liable to spate, a study of weather conditions should be made so that precautions may be taken to prevent or minimise the damage in the event of sudden rise of water level in the river. Weather warning telegram from Indian Meteorological Department may also be arranged so that the precaution may be taken in case of an expected cyclone which are very frequent in summer months. Further, an anemometer may be installed at the site of work for long triangulated spans.

2. The following arrangements should be made before actual gartering work is started:

- a) Plan the sequence of erection work.
- b) Move the girder materials to the site by rail or road.
- c) Make yard arrangements on one bank of the river or in a nearby station.
- d) Arrange the plant and equipment necessary to carry out the work alongwith spares.
- e) Test all the equipment to be used in the erection work.
- f) First Aid and communication arrangement at site.
- g) Arrange for consumable stores.
- h) Arrange for necessary traffic blocks.
- i) Arrange for a proper organisation with Supervisors, Skilled and Unskilled Staff.
- j) Provide facilities for the large labour force that will be employed at site.

### **621. Erection by use of cranes**

a) Plate girders of spans upto 30.5 m, built up complete with minimum decking arrangement, can be renewed/placed in position with the help of two cranes. Tentative sequence of regirdering operations is given below:

- i) To reduce the time of traffic block and to facilitate quick working, all rivets of the cross bracings of the span to be replaced and trough, if existing, should be cut in advance and replaced with bolts. Similarly half of the fish bolts should be removed from the rail joints and suitable speed restriction imposed.
- ii) The new span, assembled over the approach, is brought over the span to be changed using dip lorries.
- iii) Two cranes of the suitable capacity are positioned at either ends of the new span and properly supported over the approach/ adjacent span. The new girder is lifted up by both the cranes and the end brackets (temporarily attached on to both ends of girder with bolts) are lightly supported on timber supports over ends of adjacent spans. The dip lorries should be removed.
- iv) The track of the old span and cross bracings of girders are dismantled and removed.
- v) The old girders are slewed out over the skid rails slowly on either side, care being taken to guard against the toppling of the girder. The bed plates should be positioned on the bed block for the new girder.
- vi) Temporary brackets bolted at the ends of new girder are removed and the span lowered onto the bed plates. The new span is completely assembled, track laid and connected with the track on the either end.
- vii) The dip lorries are brought on the new span, old girders lifted one by one with the help of cranes and placed properly on the dip lorries.
- viii) The cranes are released and moved on to one approach, at the same time, moving the dip lorries loaded with load girders, in the same direction.
- ix) Old girders are lifted from dip lorries, with the help of cranes and stacked by the side of the track keeping them clear of infringement. The dip lorries are also removed from the track and the block section is cleared.

b) A crane with long jib can directly place spans upto 12.2 m. over the piers straight away.

### **622. Erection with Derricks**

This method is quiet simple but cumbersome and slow. However, it is quiet useful in the cases where the height of the substructure is less and number of spans are few. The job is carried out by erecting a derrick of sufficient strength and height (out of round pipe or steel lattice structure on wooden post encased in angle frame). Sufficient number of wire rope guys are tightened from the crown plate to anchorages (natural or improvised by the way of dead men) consisting of rail pieces or sleepers buried at sufficient depth in inclined pits tied with wire ropes or chains the other ends of which have been brought out above the ground level and the pits filled up and framed firmly. To these ends of wire ropes or chains are tied the ends of the guy ropes adequately with the help of proper knots and wire rope clamps.

The girders are then lifted, one at a time, after properly positioning and slinging with the help of a suitable winch and wire rope pulleys or chain pulley block or wire rope pulled by Manila rope pulley blocks. An additional wire rope will be provided just opposite to the line of action of the load so that extra load can be shared by it. The winch is located and anchored at a suitable place. Maximum precautions have to be taken to ensure rigidity of deadman or anchorages, lifting tackles, knots and fixtures, etc. If the plate girder span happens to be a semithrough one, the cross girders and rail bearers are erected with the help of same derrick after erecting the main girders. However, the main girders would have to be kept slightly wider than the exact centres to accommodate the cross girders. (Annexure 6/7).

### **623. End launching methods**

This method is normally adopted on new constructions. In this method, the girder is assembled on the approach bank and it is longitudinally traversed over the opening it has to span and lowered in position. For this purpose, a small temporary intermediate staging may be provided if required in the gap between piers for taking the girder across the gap or the existing piers and abutments are utilised.

Different techniques are adopted in different situations. Some of them are described below.

1. Launching with rail cluster method:

This method can be adopted when the number of spans to be launched are few in number and where the depth of the bed level below H.F.L. is quite high. This method is not normally used when large number of spans are involved.

a) For launching of 12.2 m spans, 2 rails of 90 lbs section are pulled across the openings on either side. After pulling the rails, wooden blocks in the form of distance pieces are inserted at intervals to prevent the tilting of the rails. The bar clamps are also fitted to the rails to prevent the rails spreading out. If the ballast walls at both ends are constructed, then the rail cluster is supported on the sleeper cribs on the abutments and piers. Suitable skids are attached to the underside of the span with the help of clamps and the rails are duly greased throughout the length to avoid excessive friction. The span is then pulled with the help of a winch on the opposite side or a pulling tackle. As soon as the span arrives at the proper position, it is jacked and the rail clusters and skid etc. removed and the span lowered on the bed plates with felt packings. H.D. bolts are inserted and grouted after aligning the span. The skidding method is not normally used where the ballast walls are high as this will involve enormous jacking. This method is used when the girders are to be launched at or near bed block level. (Annexure 6/8 a)

b) Where 18.3 m. plate girders are involved and water depth and velocity of flow is not much, the work may be carried out by erecting one or two intermediate trestles in line with the piers and abutments. The top of the trestles are adjusted to the top of bed blocks of piers and abutments. Suitably designed rail clusters are laid and the spans are skidded as explained earlier. (Annexure 6/8/b).

2. Launching by dip lorry method:-

This is a safer, more convenient and quicker method for launching of multiple spans upto 18.3m.

a) In this method, a cluster of three rails, one on each side are pulled across the opening and temporary track with wooden sleeper is laid. Distance pieces, clamps etc. are properly fitted as suggested in the skidding process above. The fully riveted 12.2m span is then brought onto the approach and one set of dip lorry on either end is inserted under it. The span is then rolled over the temporary track laid on the rail clusters (Annexure 6/8(c)). As soon as the span comes in proper position, it is supported on jacks and the dip lorry and the rail clusters are removed in phases. Finally the span is lowered on to the bed block with the jacks. In case the ballast walls are built earlier, the clusters are laid on suitable wooden cribs. In this case, the girders would have to be lowered for a considerable height.

b) This method can also be adopted for plate girders of more than 12.2m span and where it is not possible to erect intermediate trestles due to excessive height of the bed from the rail level. However instead of rail clusters, RSJs 600 x 210 mm in duplicate duly fitted with diaphragms are laid in the openings on either end by cantilever rolling method, spanning the openings. These are braced with channel diaphragms out of channels 250 x 80 x 1320mm. long at suitable intervals. Temporary track is then laid on these RSJ beams with the help of wooden sleepers to coincide with the approach track. Fully rivetted plate girder span mounted on sets of dip lorries is then rolled over this temporary track. As soon as the span comes in position, it is supported on jacks, dip lorries removed, track dismantled and the beams are shifted apart after removing diaphragms and the span lowered on the bed blocks. (Annexure 6/9 a)

### 3. Cantilever launching of spans by linking (coupling) and rolling:

An alternative method avoiding provision of staging under the span is to assemble the spans, arrange them, one behind the other, link them up by temporary links and launch them together. In such a case, the front portion of the girder acts as a cantilever till the nose tip reaches the support at the other end. As such, it has to be designed to take the cantilever stress during launching. A further improvement on this is to provide a launching nose of lighter construction and of adequate length. The spans (12.2m or 18.3 m) to be launched on the

bridge are assembled and rivetted up in one line and linked up with the help of suitable splicing. A tie for the first and second span is fitted to avoid unwanted deflection of the leading span. A suitable launching nose is attached in front to reduce the cantilevering weight of the leading span. Rolling platforms are provided on each pier and abutment under each girder of the spans. The spans are then pulled with the help of a winch making use of ordinary rounds as rollers. As soon as the spans occupy the correct position, they are jacked up and lowered on to the bed blocks after removing the tie members and the splices. (Annexure 6/9/b)

#### 4. Launching of girders with the help of a BFR:

At locations where access to the new bridge is available by rail, the launching of girders upto 18.3 m with this method is ideal. In this method, the erection tackle consists essentially of a pair of 600 x 210mm joists. The entire beam balances about a central pivot which consists of 600 x 210mm joists. The launching beam has a tackle at its balancing end, with a 3 sheaved pulley fixed on the launching beam and 2 sheaved pulley at the point where the load is taken. There is no counter weight as the advantage is taken of tare weight of the BFR itself. For the BFR to function as a counter weight, bolts are provided between the winch end of the launching beam and the BFR. With this arrangement, a completely assembled, rivetted and sleepered 12.2 m span can be lifted. (Annexure 6/10 a).

#### 5. Erection with the help of launching pad:

The BFR method described above can be suitably replaced by a launching pad since the availability of the BFR is rather difficult. The functioning of this launching pad is identical to that of the BFR and consists of combination of grillage beams mounted on 4 half sets of dip lorries, forming a kentledge. A loading trolley in the form of 'A' frame with 4 wheels (poney wheels of a steam engine) is provided in the center as shown in Annexure 6/10 b. A suitable tie is also provided as in the case of BFR. Kentledge of suitable quantity is provided on the grillage beams for additional safety. The launching pad is loaded with suitable wedges and other safety appliances. The girder is then

lowered with the help of the winch on the bed blocks to rest on cross rails which are kept provisionally on the bed blocks. The sling is then removed and the launching pad pushed back to lift second girder. In the meantime already launched girder is slewed sideways to its correct position with the help of yale pull. The second girder is then lifted and brought in the opening and lowered with the help of winch. The sling is then removed and the launching pad pushed back. This girder is similarly slewed side ways to its correct position. The bracings are then fitted, the cross rails are removed and the span lowered on the bed plates with felt packings. (Annexure 6/10/b).

#### **624. Side slewing method**

This method of construction or replacement of the superstructure is to erect girders, whether steel (trussed or plate), or precast concrete girders, over temporary supports by the side of the piers, opposite to the span and when ready, slewing the same into the position. For the ease of the movement of the girder, full or part of the deck, if any, is added after the basic girder structure with adequate bracings is slewed in. This method can be gainfully adopted in new construction by erection or casting of girders, simultaneously with the construction of the piers to save considerable time. In case of replacement of girders, similar staging will have to be erected on the other side also for the receiving the old girders and dismantling them into parts before being taken away to stores. In both cases some rolling or sliding arrangements are to be provided between the stagings and piers underneath the girder for the purpose of slewing in and slewing out of the girders. This method can be adopted when the depth of water is not more than 4 to 5m and velocity of current does not exceeds 1m/sec.

#### **625. Launching of triangulated girders on trestles**

The spans of 30.5m and above can be launched by making use of trestles. The trestles may consist of starred angles forming a square section. The profile of the pier should be such that a platform could easily be formed. A pair of trestles are fixed in the bed and a platform made between the pier and abutment. This platform consists of cluster



of 90 lbs or 52 kg rails. In the cross-wise direction , sleepers can be provided. The new girders should then be assembled from this platform. Gantry girders built up using mostly released steel, should be kept at 3.66 m centers. Steel cribs are made on the abutments and first pier. The gantry girders should initially be brought on the one end approach. Making use of pair of gallow trollies located on the erection platform , the gantries are moved in place. With this gantries, a load can be picked up and moved along the axis of the girder as well as at right angles. Thus the components of the main girders can be brought to any point on the platform. After the first main span is assembled, riveted and the track fixed on it, the gantries could be moved forward by supporting the forward end of the gantries on the gallow trollies located on the platform of opening No. 2 and the end of the gantries on a dip lorry running on a new track of span No.1 (Annexure 6/11a). This process is repeated for all spans.

#### **626. Launching of girders by using service span**

A service span can be adopted for launching of girders. The service span may be Warren truss with the verticals and cross. On the top of the service span, two numbers 5 tonnes winches are fixed at a distance. The arrangements for lifting the girders with winches consists of taking the load through a system of pulley blocks. This consists of a 2 sheaved pulley on the top and a 3 sheaved pulley at the bottom. The service span has a gantry fitted with rails over which 2 dip lorries run. (Annexure 6/11 b.)

A girder yard is provided at the approach of the bridge where the new main girders are assembled , prestressed and rivetted. One girder at a time is brought by a special 'A' frame trolley which supports the girder at the first vertical from each end. The level of the trolley is so adjusted that when the girder end is brought into the service span, the bearing end of the girder could be supported on a dip lorry provided on the gantry.

#### **627. End launching of open web girders with the help of launching nose**

This method can be adopted for launching of open web girders when the number of spans are more and the false work can not be erected in the bed.



A launching nose fabricated with light sections is connected to the main girder through a suitably designed temporary connection. The launching nose can be made of unit construction members and is assembled on rolling arrangements. The girders are temporarily connected one after the other to act as a counter weight. The whole assembly is pulled from the far bank by winches and pulleys and wire ropes. Similar restraining winches are connected at the rear of girder assembly to control the movement of the girders. As the launching progresses and touching the first pier, the deflection can be neutralised by jacking up the nose and providing adequate packing. The launching is continued till the main girders reach their respective supports. The launching nose can then be dismantled and the girders disconnected from each other. The girders are then lowered on to the bearings, already placed on the piers. (Annexure 6/12a).

### **628. Erection by cantilevering method**

The latest method of launching and erection of large span open web through girders is the cantilevering method, which is being extensively used at present. In this method, an anchor span is first erected on the approach bank adjacent to the abutment to act as kentledge. The erection of girder starts from the abutment and the erection of members ahead is done by using a derrick crane which travels on the top boom of the previously erected part structure. The first and foremost is to design and fabricate a derrick crane with a jib of sufficient length, radius and capacity. The derrick crane is fitted with suitable double flanged wheels, one set on either side, to work on the track fitted on the top booms.

A winch is fitted to the rotating platform in the front to revolve the crane for various operations. The rotating is done with the help of wheels, which are working on RSJs, in the circular beam. With the help of winch, the platform rotates either clock or anticlockwise direction as desired. The jib can be raised or lowered with the stay rope and the load is lifted by load line wire rope. (Annexure 6/12 b). Suitable arrangement can also be made to operate the crane electrically.

**629. Enveloping method**

This method is suitable for replacing of girders of long spans over large rivers, where it is difficult to erect any temporary staging on the bed or the piers are very tall. The method is very cumbersome and time consuming, and as such is normally adopted only when all other methods of regirding are not feasible. In this method, the new girder wide enough so as to completely envelop the existing girder is rolled in with the help of a set of trollies or rollers fitted on the top boom of the existing girder. After new girder reaches in correct position, the floor system of the old girder is replaced by the floor system of new girder and the load transferred to the new girder. The old girder is then taken out. In case, the new girders are not designed to be so wide, a temporary enveloping girder is made and the above process is repeated. A standard new girder can then be launched inside the temporary girder and the flooring system replaced with that of standard girder. The temporary enveloping girder is then moved on to the next span.



## CHAPTER -VII

### RIVERS AND FLOODS

#### 701. Behaviour of rivers

1. The Divisional Engineer and Assistant Engineer should acquaint themselves with the past history of every important/vulnerable bridge, river training/protection works and the behaviour of the rivers in their jurisdiction, in order to ensure safety of railway structures during floods.

2. The permanent way Inspector/works Inspector should acquaint himself with the behaviour of rivers and the bridges in his section with their past history and organise timely precautionary measures on sections/bridges liable to be flooded or breached.

#### 702. Past History of bridges

The Divisional Engineer and Assistant Engineer should have details of bridges and river training works which have past history. The information can be conveniently contained in a register, based upon an examination of bridge inspection registers and flood damage reports of the past 10 to 15 years.

The examination may include:

- 1) Wash aways;
- 2) Abnormal high flood levels;
- 3) Heavy afflux;
- 4) Deep scour near piers and abutments;
- 5) Settlement or tilting or shifting of piers and abutments;
- 6) Overtopping or breaching of approach banks;
- 7) Diversion of live channels from one bridge/ span to another;
- 8) Damage to guide bunds, protective spurs and flood banks or marginal bunds; and
- 9) Aggradation and degradation of rivers.

In this respect, no distinction should be made between important, major and minor bridges.

The register should form a part of the documents handed over

during change of incumbency. It should be updated annually as necessary.

### **703. Danger level at Bridges**

1) The danger level is that level which when reached, safety of the bridge is likely to be adversely affected.

2) All traffic shall remain suspended till such time a responsible official as specified in para 706 inspects the bridge, track and approaches thoroughly and declares it safe for the passage of trains.

3) The danger level shall be fixed for each bridge by the Divisional Engineer with great caution and due regard to the conditions obtaining at site. In deciding danger level, various factors such as nature of soil, depth of foundations, existence of drop and curtain walls, flooring, depth of maximum permissible scour, the highest recorded flood level, the level of the bottom of girders, the springing level of arch, top of the guide bunds, free board to be allowed, velocity of water observed at bridge site, afflux noticed and past history of the bridge are to be taken into account. In fixing the danger level, a margin of safety should be allowed taking into consideration the characteristics of the river or stream such as, whether it is subjected to sudden flood or gradually rising floods and whether it carries floatsam. Fixing of danger level at a higher level than necessary may result in unnecessary restrictions to traffic and may lead to non seriousness with regard to implications of action required in case of water level approaching or exceeding danger level.

4. Danger level shall be the level which is lower of the following:

- a) the level which provides adequate vertical clearances;
- b) the level which provides minimum free board to approach banks and guide bunds, as stipulated in clause 4.9 of Bridge Substructure Code,
- c) the level of water which is likely to cause an unduly large afflux, say more than 0.5 m, which may cause large scour endangering the bridge; and
- d) the water level which if exceeded may cause excessive scour endangering the bridge.

5. In cases, where there is no past history of damage or serious threat to the bridge, free boards are adequate for approach banks and

protection works, no excessive afflux say more than 0.5 m is observed/ anticipated and no excessive scour endangering the bridge has occurred/been anticipated, the broad guidelines for fixing Danger Level are given below:

a) Girder and Slab Bridges:

	<b>Waterway</b>	<b>Clearance below bottom of girders/slabs</b>
i)	< 6.10m	150 to 300 mm depending on the span and site conditions.
ii)	> 6.10 < 12.2 m	450 mm
iii)	> 12.20 < 30.5 m	600 mm
iv)	> 30.50 < 61.0 m	750 mm
v)	> 61.00m	1200mm

b) Arch Bridges:

- i) For small arch bridges of spans less than 4.0m, the danger level shall normally be at the springing level;
- ii) For larger spans and for multiple span arches, the danger level shall be at 2/3rd rise below the crown of the arch;
- iii) Where higher HFLs have been recorded in the past, without any dangerous afflux or scour, or damage to approach embankments, danger level may be raised suitably at the discretion of Chief Bridge Engineer.

c) Box Culverts:

Danger level at the bottom of slab.

d) pipe Culverts:

Danger level at the top of inside of pipe.

e) Balancing Culverts and bridges:

Danger level at 50mm below top of pier/ abutments in case of culverts with girders and slabs or the crown intrados of the arch.

6. The values suggested in sub para (5) above are for general guidance and should be used where specific guidelines have not been issued by the zonal railways based on the past experience and local

conditions. Railways which have already issued guidelines may review the existing instructions and supplement the same as considered necessary.

In case where danger to bridge has occurred or the bridge has been seriously threatened, even though the water level was less than the danger level, the revision of danger level should be considered.

7. In case where floods higher than danger level have occurred several times in the past without causing any damage to the structure, the desirability of revising the danger level may be examined.

8. Fixing of the Danger level for any new bridge or any revision of the existing Danger level should be done with the approval of the sectional Divisional Engineer/Senior Divisional Engineer Incharge, who should record the reasons for revising the Danger level.

9. All danger levels should be recorded in the bridge inspection register.

10. Marking danger level:

The danger level should be marked on the abutments or on the first and last pier of the bridge. In the case of long multiple span bridges, the danger level mark should be repeated suitably on intermediate piers. These marks should be fixed on the upstream side of the bridge, conspicuously visible to the inspecting officials, patrolmen and watchmen. The danger level should be marked with a bright red band 5 cm wide centrally over a white band 10 cm wide for a length of 60 cms.

#### **704. Watchmen at bridges**

1. Based on the past history of the bridge and behaviour of the river the Divisional Engineer will decide as to the bridges where watchmen are to be posted during the monsoon period and the period of their posting. Provisions of para 1014 of the Indian Railway Permanent Way Manual shall also apply.

2. Only intelligent, reliable and experienced men, who can read numbers, should be selected as watchmen. As far as possible, they should be from the permanent gangs.

**705. Duties and equipment of bridge watchmen**

1. They should be well conversant with the rules regarding the use of hand signals, detonators and protection in the case of emergency.

2. They shall be provided with the following equipments.

- a) Two Red Flags.
- b) One Green Flag.
- c) Two Hand Signal Lamps.
- d) 10 Detonators.
- e) Flare Signals ( where prescribed).
- f) Whistle Thunderer.
- g) Match Box.
- h) A keying and spiking Hammer.
- l) A Fish Bolt Spanner.
- j) A Gauge cum Level.
- k) A Staff to Exhibit the Flag / Lamp .
- l) A Powerful Torch.
- m) Probing Rods if required.

3. They should walk over the bridge and where possible, under the bridge also, carefully inspecting every portion of the bridge for any sign of failure.

4. They should apprehend danger when any one or more of the following occur:

- a) the flood reaches or exceeds the danger level;
- b) danger to the bridge, its approaches or protection work, even before the danger level is reached such as disturbance to alignment and or longitudinal level of track on the bridge due to shifting or settlement of piers/ abutments;
- c) water on one side of embankment at a much higher level than on the other side, resulting in seepage or piping through embankments;
- d) the crack on the approaches showing signs of settlement ; and
- e) large scale obstruction to the water way of bridge.

5. If danger is apprehended, they should arrange to protect the track and stop the traffic as laid down in para 1011 of the Indian Railway Permanent Way Manual. They should then report the same to the Gang Mate, by the quickest available means.

6. When no danger is apprehended, they should stand on the left hand side of the train and blow the whistle when the engine and brake van pass.

7. When the water level is rising and likely to approach the danger level, they should arrange to send a report to the Gangmate /Permanent Way Inspector immediately.

8. Where gauges are fixed at these bridges, they should record the gauge readings, whenever directed to do so.

9. They should watch for floating trees and other floatsam entangled against piers, spurs and guide bunds and arrange to disengage them with the help of Permanent Way Gangs as necessary.

**706. Action to be taken by the Permanent Way Inspector at site**

1. On receipt of the message apprehending danger, the Inspector will immediately reach the site and ensure protection of track, if not already done.

2. After examining and ensuring that the bridge, its approaches and protection works are in safe condition, if necessary, by taking sounding and probings, the Inspector may allow the trains at such speed, as he may decide, depending on the conditions at site .

3. The Inspector shall advise the Assistant Engineer giving the following particulars copying the message to the Divisional Engineer:

- a) Flood level and its position with reference to danger level, rising or falling;
- b) Difference or level between upstream and downstream, action/ effect of flood on the bridge or protection works;
- c) Any special action required.

**707. Special Inspection during monsoon**

During floods and/or during spells of heavy rain the Assistant Engineer, Permanent Way Inspector/Inspector of Works should inspect by trolley, foot-plate of the engine or other means, the bridges and allied works, as frequently as necessary. Where a strong rush of water and heavy afflux occur, they should look for the presence of eddies and backwaters which are signs of danger. When these are observed,



sounding with the help of echo sounders or probing with the help of log line with a heavy lead weight, rail piece or probing rod must be taken and if scour is detected, boulders or pitching material should be runout and dumped as necessary. As a precautionary measure, traffic may be suspended if long lengths of track with a large number of bridges experience a flood situation and scour can not be measured, particularly during night time.

**708. Action to be taken in the case of weather warning**

On receipt of weather warning messages from the Meteorological Department or weather forecast made by All India Radio, Doordarshan forecasting heavy rainfall, Permanent Way Inspector will take action as per para 728 of the Indian Railway Permanent Way Manual.

**709. Pitching stone, boulder and other monsoon reserves**

1. Locations and quantity of reserve stock of pitching stone, boulder and other monsoon reserves should be fixed by the Chief Engineer / Chief Bridge Engineer.

2. Arrangements should be made to stock them before the onset of monsoon at locations specified in stacks or in loaded wagons.

3. Reserve stock should not be used except in emergency; where it is used, it should be recouped.

4. The “Reserve” for use in bridges should be stacked at suitable locations above the HFL close to the bridge and the protection works.

5. Before the onset of monsoon on a date to be specified a certificate should be sent by the Inspector in Charge in the following form:

<b>CERTIFICATE</b>	
<p>“ I certify that all monsoon reserve stocks as specified, have been recouped with the exception of the following for which action has been taken as indicated below: _____</p>	
Date :	Signature :
	Designation :

6. The annual return of pitching stone, boulder and monsoon reserve should be submitted by each Divisional Engineer to the Chief Bridge Engineer by specified date after the monsoon. It should be accompanied by a statement of training works added or abandoned during the year with recommendation for reduction or increase to the Reserve”.

7. Permanent remedial measures should be taken as soon as possible in every case and recurring expenditure avoided or minimised.

8. Attention to paras 724 and 725 of Indian Railway Permanent Way Manual is drawn regarding the other monsoon reserves.

### **710. Flood records**

1. A list of bridges across large alluvial rivers and such other rivers as identified by Chief Bridge Engineer should be prepared to maintain the flood records as noted below:

- a) Soundings around piers and abutments during and after high floods;
- b) Gauge readings of flood level during monsoon;
- c) Observations of afflux and velocity during monsoon;
- d) Cross sections of river during and after floods:
- e) Survey of the river course after monsoon;
- f) Cross section of guide banks/protection works and their aprons;  
and
- g) Annual survey of scour holes.

The details of flood records that are to be maintained should be specified for each of the bridges.

### **711. Flood records during monsoon**

1. Sounding During Floods:

a) Soundings at specified bridges should be taken in mid span and around piers and structures, when flood is at or about the danger level. In the case of large alluvial rivers, soundings may be taken when the flood is 2/3 of the maximum flood rise above the normal low water level which may be marked on the piers/abutments. The periodicity of taking soundings should be specified taking all factors into account with atleast one sounding to be taken daily.

b) Special care should be exercised when taking soundings, specially in rapid water, to ensue that they are trust-worthy. Lead or rail-piece of proper weight and log line or echo sounders of reliable quality should be used. The weight should first be lowered upto the bed as far as it can go then raised by a small extent and lowered again and the process repeated three or four times until the inclination of the log line to the vertical is as small as could be obtained. The level of the river bed below the point of suspension is assessed from the length and inclination of the log line and the probability and extent of scour gauged from comparison with the figures on the inscription plaque fixed on piers and abutments which indicate the nature and depth of foundations.

c) Safe scour depth below rail level should be fixed by the Chief Bridge Engineer for all the bridges having well/pile foundations by making reference to completion drawings and inaccordance with para 4.6 of the Code of Practice for Design of Sub-structures and Foundation of Bridges. The safe scour depth should be indicated on the top of pier.

d) Should the sounding at any pier exceed the safe scour depth, the Inspector-In-Charge will stop traffic and commence dumping of boulders advising all concerned. The dumping of boulders should be continued till the soundings indicate that maximum scour depth is less safe scour depth. Dumping must not be started until the scour has actually gone below the safe scour depth.

## 2. Gauging, Velocity and Afflux Measurements During Monsoon:

a) Water level should be recorded daily at the specified bridges, during the monsoon period and a register should be maintained as per proforma given in Annexure 7/1. In addition to gauge and afflux readings accurate record of maximum flood levels and the rate of rise and fall of flood levels must be recorded in the register.

b) Divisional and Assistant Engineers should ensure that gauges are erected and maintained at all specified bridges both on the upstream and downstream side.

c) Levels painted on gauges should be accurate and all gauges must refer to the same datum. Where gauges are painted on piers, these should be used only for the purpose of reporting high flood levels at bridges and not for determining the afflux as it is liable to give incorrect readings.

d) Afflux gauges should be fixed at a distance of about 30 metre upstream and downstream of the bridge opening, preferably at near still water so that these are not affected by swiftly moving currents.

e) Velocity of flow should be recorded using floats or current meter at all the specified bridges. In non erodable beds, velocity measurements should be made avoiding the regions of turbulent flow (adjacent to piers) and in case of erodable beds, the measurements should be made near as well as away from the pier. When current meter is used necessary stagings or platforms should be provided on the pier.

f) For gauging and velocity measurements, reference may be made to RDSOs Gauging Manual.

### 3. Cross section of rivers during floods:

For such bridges as specified, cross section diagrams of the river bed near about the high flood level at specified locations on the upstream and downstream side should be prepared to a fixed scale in the Divisional Engineer's office from particulars submitted by the Assistant Engineer and copies sent to the Headquarters office by the prescribed date each year. The diagrams should show the reduced levels of the summer water level, the highest known flood level and the year, the underside of girders or springing of arch and the rail level. Five years records may be plotted on each diagram in different colours for comparison. After one set is completed another set for the next five years should be commenced with the same order of colours. A typical cross section diagram is at Annexure 7/2

## 712. Flood records after the monsoon

### 1. Cross Section Diagram After Floods:

Soon after the monsoon, as practicable, sections across the bed of such rivers as specified by the Chief Bridge Engineer should be taken on the up and down stream sides, clear of piers and abutments by sounding if necessary and particulars submitted to the Divisional Engineer. These should be taken on the same alignment year after year for proper comparison. For these bridges, cross section diagrams of bed of the river on the up and down stream sides should be prepared in the Divisional Engineer's office to a fixed scale and copies sent to the

Headquarters office by the prescribed date each year.

Each diagram should show, in addition, reduced levels of the particulars mentioned in para 711.3 and may indicate the record over five years in different colours. After one set is completed, another set of records should be commenced with the same order of colours. The cross section should be prepared in the same manner as shown in Annexure 7/2

2. Annual survey of scour holes at bridges:

It is necessary to survey scour holes both on the upstream and downstream after monsoon to find out the size and depth of the scour holes and the distance of the same from the foundation so that remedial measures can be planned in time and the works executed before the onset of the next flood season, as necessary.

A list of all bridges where scour holes exist should be prepared and copy sent to Chief Engineer every year along with the flood report.

3. Survey of the course of the river:

a) At each specified bridge, survey of the course of the river to a fixed scale should be made soon after the monsoon extending to at least 3 km upstream and 1 km downstream of the bridge to afford general idea of the efficiency of training works. The distance may be suitably modified keeping in view the past history at the discretion of the Chief Bridge Engineer. A tracing of the survey will be prepared in the Divisional Engineer's Office and copies sent to the Headquarters each year. For comparison, five years record may be plotted on each survey plan in different colours. After a set is completed, the next set should be commenced with the same order or colours. A typical survey plan of the course of the river is enclosed as Annexure 7/3.

b) Where a river course runs parallel to the track with a tendency to encroach towards the Railway embankment, the course of the river should be surveyed to get a general idea of the rate of erosion. A danger line should be drawn in the survey plan to indicate as to when remedial action such as holding the river edge away from the danger line or retiring the Railway line has to be taken.

4. Cross section of guide, subsidiary and retired bund:

At the end of the monsoon, cross sections should be taken at

every 30 metres along each stone protected bund or groyne and at every 15 metres apart round each stone armoured mole head by probing, if necessary and particulars submitted to the Divisional Engineer. Cross sections should be prepared in the Divisional Engineer's office to a fixed scale and copies sent to the Headquarters office. These cross sections will indicate the position in the slopes and apron, the progress of the apron pitching towards its ultimate launching position and will bring to light any defects that may require attention in the dry season. For comparison, five year's records may be plotted in different colours on the same drawing. After one set is completed, the next set should be commenced with the same order of colours. A typical cross section record maintained is enclosed as Annexure 7/4.

### **713. Attention to damages**

The Divisional / Assistant Engineer should carry out inspection of Bridges and their training works after the rainy season and take action to undertake repairs and make good the damages before next rainy season. Proposals for new works should be framed and sent to Chief Engineer for approval and these works completed before the onset of floods.

### **714. Rivers and flood register**

1. Continuous records of the behaviour of large alluvial and other specified rivers and the condition of training and protection works of the bridges across them, if any, should be maintained by the Assistant Engineer in a "Rivers and floods" register. This register may be in a manuscript form with sufficient number of pages allotted for each bridge to cover ten to fifteen years and should contain:

a) Brief history of the bridge and protection works at and away from the bridge site with plans and sections.

b) Condition of foundation and protection works with particulars of action taken on repairs required.

c) Particulars of flood damage and remedial measure adopted with reference to Bridge Inspection register. Blue prints of the cross section diagrams of the bed of the river, survey plans of the course of the river and cross sections of bunds vide para 711 and 712 should be attached to the register for reference. Past register should be carefully preserved.

2. The Assistant Engineer shall submit the register to the Divisional

Engineer by a prescribed date, indicating the point on which the orders of the Divisional Engineer are required.

The Divisional Engineer shall carefully scrutinise the register, examine such works as called for his inspection, record his orders regarding the points referred to him and initial against every bridge or kilometreage in token of his scrutiny. Points on which the Territorial Head of the Department's decision is required shall be clearly indicated.

The register should then be sent to the Assistant Engineer for noting the Divisional Engineer's Orders with instructions to return it within 15 days. The Assistant Engineer should extract the orders issued by Divisional Engineer and arrange expeditious compliance.

The register should then be forwarded by a prescribed date to the Headquarters Territorial Head of the Department who will scrutinise the entries, issue orders regarding matter referred to him endorsing the register to that effect, and return it to the Divisional Engineer. Subsequent action taken on HOD's notes should be entered in the register by the Assistant Engineer.

### **715. Flood reports**

During the flood season, written reports of damages must be sent promptly by the Divisional Engineer to the Chief Engineer within three days of the occurrence. These should be submitted in the proforma shown in Annexure 7/5

In addition to the information given in the proforma, consolidated descriptive report of the flood damages should be sent to the Chief Engineer indicating action taken or proposed to be taken to repair damage.

### **716. Rainfall Data**

1. A list of rain gauge stations must be maintained in the Divisional Engineer's Office showing the designation of person who is responsible for recording the rainfall every day at 08.00 AM. On any day when the rainfall recorded is 75 mm or more the fact should be intimated to the Assistant Engineer/Divisional Engineer and Chief Bridge Engineer by the person responsible for taking the gauge reading. When there is very heavy rainfall, hourly readings should be taken to assess the

intensity of rainfall. Self recording rain gauges may be advantageously used to get accurate and reliable data.

2 . Along with the flood reports (para 715), a statement of monthly rainfall should be submitted for all the rain gauge stations on the Division in the proforma shown in Annexure 7/6

### **717. Provision of anemometer on bridges**

On selected bridges, where high winds are experienced and there is a danger of vehicle capsizing, anemometers should be installed at one of the railway station close to the bridge and suitable working rules should be framed prescribing for each location the maximum permissible wind velocity. The limiting wind velocity should be specified by the Chief Engineer which should not exceed 72 Kmph. It should be enjoined that the Station Master should control/stop the traffic on the section concerned when the wind velocity exceeds the limits. He should also inform the Station Master on the other side and the section controller of the need to control the traffic. In selecting bridges, the previous experience and the occurrence of the accidents should be the guiding factor.

□□□



## CHAPTER-VIII

### RIVER TRAINING AND PROTECTION WORKS

#### 801. Training / Protection of various types of rivers

The object of river training/protection works is to prevent the river from damaging railway formation, bridges and other structures. The training/protection works will have to be decided depending on the reach in which the river is situated namely:

- a) Upper reaches (Mountainous)
- b) Submontane reaches (Foot hills)
- c) Quasi-alluvial reaches (Trough)
- d) Alluvial reaches, and
- e) Tidal reaches

#### 802. Upper Reaches (Mountainous Rivers)

##### 1. Characteristics:

These streams have narrow and deep cross section with very steep bed slopes. The gorge is often deep and narrow with formation of rapids. The discharge is extremely variable and their beds are interspersed with large size bed material consisting of rock, boulders, shingle and gravel. The rise of flood in them is very sudden and flashy. The water is heavily sediment laden, with high concentration of suspended load.

##### 2. Suggested protective measures:

The following protective measures are suggested/ recommended for adoption.

a) Suitable protective fenders of concrete, rolled steel or rails may be provided upstream of the bridge to reduce the impact on piers and abutments due to rolling boulders down steep slopes.

b) Measures for controlling soil erosion and landslips, improving stability of side slopes and arresting bed load in boulder bedded hilly terrains should be undertaken.

c) The formation of gullies by the water coming down the hills can be prevented by afforestation, construction of gully/ check dams, contour

bunding, debris basins, chambers or wells. These should be cleaned as frequently as necessary.

d) Stability of side slopes can be improved by provision of adequate drains, breast and toe walls etc.

e) Properly designed chutes with paved apron at the entrance with adequate free board may be used in Railway cutting for leading the water of mountainous streams down the hill slopes. Alternatively, suitably designed catch water drains on water-shed side may be constructed.

### **803. Submontane Reaches (Foot Hills)**

#### 1. Characteristics:

The rivers in these regions have a flatter bed slopes generally form 1 in 50 to 1 in 500. The velocity and its sediment transporting capacity gets reduced encouraging deposition of excess sediment load.

Medium size boulders, gravel and coarse sand are generally found in the beds. The floods are of flashy nature. These streams are highly erosive and the erosion proceeds through grinding of bed load material during transport, formation of deep holes through whirlpools and plunging action along with cliffs forming the banks, in the higher reaches. These actions go on widening the bed and deepening the channel. The flow in the channel, except during highest stages, is insufficient to transport the detritus which gets deposited blocking the original channel; another channel may then be formed and in course of time the river bed may become a net work of such channels with islands in between. Such streams are called "Braided" stream (Annexure 8/1). All these channels normally overflow during high floods and the river acquires very wide and shallow cross section. The rivers in this reach are prone to progressively raise their beds by sediment deposition. Such rivers are known as "Aggrading" type.

In these case, the over bank spills increase year after year, until occurrence of abnormal floods in a year, when sudden change of course may take place.

#### 2. Suggested protective measures:

It is not desirable to locate bridge in such reaches. However, if a bridge is to be provided, training measures in the form of marginal

bunds, extending right upto the high ground in the hills are required to shift the point of aggradation downstream. To reduce the erosive action on the marginal bund

- a) Suitable slope protection with boulders or concrete slabs,
- b) adequate toe protection in the form of two rows of in-situ concrete blocks or boulders in wire crates and
- c) boulders in wire crates forming flexible type apron may be provided.

#### **804. Quasi-Alluvial Reaches (Trough)**

##### 1. Characteristics:

In this reach, the bed slope varies from 1 in 500 to 1 in 2,500. The bed consists of small size gravel and medium sand. The channel has generally a well defined course.

##### 2. Suggested protective Measures:

Bridging such rivers normally involves constriction in width and provision of guide bunds. Assistance of specialised agency, undertaking hydraulic model studies may be availed of, as considered necessary.

#### **805. Alluvial Reaches**

##### 1. Characteristics:

In this reach, the river bed slope varies from 1 in 2,500 to 1 in 25,000. The river flows on an almost flat bed built by its alluvium. The alluvial river meanders as a whole within its "Khadir" (a strip of low land within which a river meanders and its flood rises). (Annexure 8/2).

The main difference between the alluvial and quasi-alluvial rivers is that the former meanders as a whole within its "Khadir" while the latter has well defined banks and it is only during periods of low water that the channels meander. Rivers in alluvial reaches are normally stable with no perceptible lowering or raising of the river bed in the course of the years.

##### 2. Suggested protective Measures:

The training of alluvial rivers is generally on the same lines with guide bund system as described for quasi-alluvial rivers. The meanders do not remain fixed but usually travel down stream. Every effort should be made to keep the river to its original course near the bridge . In

some cases it is observed that the main current of the river starts flowing along the railway bank on the upstream side due to the meander travel downstream. The building of spurs along the railway embankment is not a good remedy, as it perpetuates the main channel along the Railway alignment. In such cases every effort should be made to divert the river to its original course. In some cases the construction of a second control point consisting of a spur about 0.4 times the meander length has been found to be satisfactory. The exact length and location of such works however, should be determined through model studies in a hydraulic laboratory.

**806.** At the confluence of the river with the sea, the tidal effects predominate. Constriction of the water way is to be avoided in these reaches and tidal regime is to be kept in view, while designing bridges.

#### **807. South Indian Rivers**

The river system in south India is geologically older and stable. Tendency for shifting of the river bed course and aggradation/degradation is insignificant. Problems of river training and protection normally do not arise except in the deltaic region/tidal reaches.

#### **808. River Training Works**

The following types of river training works are generally adopted on the Indian Railways:

1. Guide Bunds;
2. Spurs (Groynes);
3. Marginal Bunds;
4. Closure Bunds; and
5. Assisted cut offs.

#### **809. Guide Bunds**

1. Necessity:

Guide bunds are meant to confine and guide the river flow through the structure without causing damage to it and its approaches. They also prevent the out flanking of the structure.

2. Shape and Design Features:

a) The guide bund can either be divergent upstream or parallel. In

the case of divergent guide bund, there is possibility of formation of a shoal at the center. Parallel guide bunds minimise obliquity and separation of flow along the flanks. According to geometrical shape, the guide bunds may be straight or elliptical. In the case of certain type of alluvial rivers with sandy bed and meandering pattern, elliptical shape appears preferable to minimise obliquity and separation of flow.

Various types of guide bunds are shown in Annexure 8/3.

b) Normally the upstream shank of the guide bund is between 1.0 to 1.5 times the length of the bridge, while the downstream shank is between 0.2 to 0.4 times the length of the bridge.

c) The tail bund on the downstream side is provided to afford an easy exit to the water and to prevent formation of vertical whirlpools or rollers which give rise to scour. These tail bunds are also curved at their ends and should be properly armoured.

d) The guide bund is provided with a mole head on its upstream side. The mole head bears the brunt of the attack and should be provided with adequate protection in the form of slope pitching and properly designed launching apron. The shank i.e. the portion behind the curved mole head of the guide bund should also be similarly protected on the river side. The slope in the rear of the guide bund need not necessarily be provided with pitching and may be protected by planting grass or shrubs as found suitable.

e) No spurs projecting from the guide bunds should, in any case, be provided.

f) For design and construction of guide bunds/launching aprons reference may be made to IS: 10751-1983 and IRC: 89-1985.

### 3. Apron Protection :

Apron is provided beyond the toe of the slope of the guide bund, so that when bed is scoured, the scoured face will be protected by launching of the apron stone or wire crate containing stone. A typical lay out of a guide bund is shown in Annexure 8/4.

### 4. Maintenance :

a) Substantial reserve of pitching stone should be maintained on the guide bund for use during emergency. This should be stacked at the top of the guide bund.

b) The track on the guide bund, where provided, should be maintained in a satisfactory condition and should be capable of taking boulder trains at any time. The Permanent Way Inspector and the Assistant Engineer should inspect the track soon after the monsoon every year and carry out necessary repairs well before the next monsoon.

c) Every effort should be made to ascertain whether the apron is launching to the intended position and this should be done by probing after the flood season is over. Plotting of the levels will indicate the efficacy of the launching.

d) Disturbance of pitching stone on the slope indicates dangerous condition and additional stones should be placed in position immediately as necessary.

5. Failures and remedial measures:

The conditions under which an apron of the guide bund can fail and remedial measures to be adopted are stated below:

a) If the launching takes place beyond the capacity of the stone in the apron and results in leaving the bank material exposed to the current and wave action, more stone will have to be added to the apron.

b) If stones are carried away by high velocity current from the launching apron and the toe of the bund, the apron should be strengthened against severe attack by laying large sized stones at the outer edge of the apron.

c) If slips and blow-outs in the bund occur due to a steep sub soil water gradient resulting from a rapidly falling flood in the river, the bank should be widened to reduce the hydraulic gradient. This equally applies to marginal bunds.

d) Wherever disturbance is noticed in rear of guide bund due to wave lash or other causes, the slope pitching should be adopted as a remedial measure.

e) An apron can launch satisfactorily only if the material scours easily and evenly and the angle of repose of the underlying material is not steeper than that of the stone.

In all these cases action should be taken to dump the boulders on the toe of the bank and make up irregular surface.

**810. Spurs (Groynes)**

1. A spur/groyne is a structure constructed transverse to the river flow and is projected from the bank into the river.

2. Type of spurs /groynes:

i) They may be either "Permeable " or "Impermeable". Permeable spurs are constructed by driving wooden bullies or bamboos, filled in with brush wood, with sarkanda mattresses or other suitable material. These are helpful in causing quick siltation due to damping of velocity. They are useful when concentration of suspended sediment load is heavy; they allow water to pass through. Impermeable spurs are made of solid core, constructed of stones or earth and stones with exposed faces protected by pitching. These spurs can withstand severe attack better than permeable spurs.

ii) Spurs may be classified as (a) repelling (deflecting) (b) attracting and (c) neutral (sedimenting ). Repelling (deflecting) spurs are those which incline upstream at an angle of 60 degree to 70 degree to the river course and deflect the current towards the opposite bank. They cause silting in still water on the upstream pocket. Attracting spurs incline downstream and make the deep channel flow continuously along their noses. They cause scour just on the downstream side of the head due to turbulence. The river flow is attracted towards the spur. Normal (holding or sedimenting) spurs are those which are built at right angles to the bank to keep the stream in a particular position and promote silting between the spurs. They have practically no effect on the diversion of the current and are mostly used for training of rivers for navigational purposes.

iii) Spurs are also classified as full height spurs and part height spurs. Where top level is higher than HFL, it is called a full height spur.

iv) Spurs are also constructed extending into the stream with a "T" head or hockey stick shaped head, properly armoured to hold the river at a distance. A series of such spurs/groynes correctly positioned can hold the river at a position away from the point intended to be protected. The edge of the "T" head should be curved somewhat in the manner of a guide bund to avoid swirls. Sketches of the various types of spurs may be seen in Annexure 8/5.

### 3. Location and salient features of a spur/groyne:

i) The space between spurs or groynes generally bears a definite ratio to their length. The common practice is to keep the spacing at about 2 to 2.5 times the length so as to effectively protect the bank.

ii) If designed as a full height spur, care should be taken to see that spurs are built sufficiently high so that they are not overtopped and out flanked by the current during high floods. Free board of 1 metre is provided.

iii) The side slope of spurs are generally 2:1.

iv) The spurs should be anchored on to high ground.

v) The head of the spur is most vulnerable point for scour and should be well protected on slopes by pitching and at toe by an apron designed for scour depth of 2.5 to 2.75 times  $D$  lacey at the mole head.

vi) Spurs should never be constructed at a point where severe attack is taking place but at some distance upstream.

vii) Spurs/groynes should be used only in-situation where they are absolutely necessary.

viii) The design of spurs may be finalised preferably through hydraulic model studies.

### 4. Maintenance of spurs/ Groynes:

In all cases, satisfactory arrangement should be made for the maintenance of spurs/groynes by providing access to them during all seasons of the year and keeping boulders as reserve.

The maintenance procedures specified for guide bunds apply equally to spurs/groynes also.

## 811. Marginal Bunds

Marginal bunds are provided to contain the spread of the river when the river in flood spills over its banks upstream of the bridge site over wide area and likely to spill in the neighbouring water courses or cause other damages. The marginal bund should normally be built well away from the active area of the river. The slope should be well protected by turfing. Where a marginal bund has to be built in the active area of the river, it should be protected with pitching and apron. The earth for



the construction of marginal bund should preferably be obtained from the river side. The upper end of the marginal bund should be anchored into high ground well above HFL. Marginal bunds should be inspected every year along with the annual bridge inspection and necessary repairs should be carried out before the onset of monsoon. Cattle crossing and rodent holes across the marginal bund should be specially watched and deficiencies made good.

### **812. Closure Bunds**

Sometimes it may be necessary to entirely block one or more channels of the river in order to prevent the discharge of such channels developing into a main river channel after the construction of the bridge. This is done by providing a closure bund. The bund is designed as an earthen dam. The same is generally constructed at some distance from the railway line. special care should be exercised to guard it against its failure. It should be inspected every year after the monsoon and necessary repairs carried out.

### **813. Assisted Cut- Offs**

Sometimes when very heavy meandering develops near bridges and there is a danger of its encroaching too heavily into the still water area or otherwise dangerously approaching the railway embankment, it becomes necessary to dig a cut-off channel which will ultimately develop and help in the diversion of water through it. To effect economy, a pilot channel cut is usually made when there is low flow in the river and full development of the channel takes place during the flood. This cut off channel should preferably have (i) atleast three times the river's straight regime slope and (ii) the upstream end should take off from where the bed load of main channel has less than the average amount of coarse material i. e. from the active part of the channel where the velocity is more. The entrance to the pilot cut should be bell shaped to facilitate entry of water. The chord loop ratio should normally be greater than 1 to 5 if a successful channel is to develop. Cut off should be planned with care taking all relevant factors into account (Annexure 8/2).

### **814. Protection of Approach Banks**

1. Approach banks of bridges may be subjected to severe attack under the following conditions:

i) When the HFL at the bridge is very high and there is spill beyond the normal flow channel.

ii) When the stream meets a main river just downstream of the bridge.

iii) In the case of bridges with insufficient water way.

iv) The wave action on the approach bank of bridges situated in a lake/large tank bed may have a detrimental effect.

In all the above cases the pitching of the approach bank upto HFL with sufficient free board is an effective solution. Provision of toe wall and narrow apron in some cases will also be useful.

2. If deep borrow pits are dug near the toe of approach banks, the water flows through these pits and forms a gradually deepening water course which may eventually threaten the safety of the approach bank. In this case it will be useful to put rubble "T" spurs across the flow to reduce the velocity and expedite silting of the course.

3. Whenever the water level on either side of an approach bank is different, there may be seepage of water and to ease the hydraulic gradient, widening of banks, provision of sub banks and toe filters etc may be resorted to.

4. At locations with standing water against the embankment, special watch should be kept when the water level recedes rapidly and when slips are likely to occur.

### **815. Design of river training works through model studies**

In case of large alluvial river where training/ protection works involve a heavy financial outlay, model studies should be resorted to, to arrive at the most economical and effective solution.

□□□

**CHAPTER IX**  
**FABRICATION, ERECTION, INSPECTION**  
**AND MAINTENANCE**  
**OF OTHER STEEL STRUCTURES**

**901. Inspection by Bridge Inspector**

1. When specifically ordered by the chief Engineer/ Chief Bridge Engineer the Bridge Inspector should inspect the steel works in the Loco shed and workshop structures and any other light steel structures at such frequency as decided by the Chief Bridge Engineer.

2. Inspection Register: The Bridge Inspector shall record the results in the Structural Steel Inspection Register to be maintained in manuscript form (Annexure 9/1) and submit the same by the prescribed date to the Assistant Engineer (Bridges) /Divisional Engineer (Bridges) who should scrutinise the entries, issue such orders as deemed necessary and return the register. Prompt action should be taken to carry out repairs required.

3. Inspection by Assistant Engineer (Bridges) / Divisional Engineer (Bridges).

a) The Assistant Engineer (Bridges) / Divisional Engineer (Bridges) will inspect the steel structures mentioned in Para 901.1 once in five years and shall record results of his inspection in the Structural Steel Inspection Register maintained by the Bridge Inspector and ensure expeditious compliance of notes recorded.

b) The Bridge Inspector shall accompany during the inspection.

c) Structures warranting special attention should be inspected more frequently.

d) Entries in column " Condition of structure at the time of inspection" should be in the nature of statements. A defect, once mentioned should not be omitted in future years unless it has been eliminated through repair in which case a note to that effect should be made.

#### 4. Details of inspection:

During inspection of the steel works in various structures, the following points should be examined:

- i) the condition of foundation base of stanchions ,
- ii) the condition and tightness of foundation bolts,
- iii) the condition of steel work in stanchions, wind girders, roof trusses/girders, purlins, eaves girders and wind bracings, etc.
- iv) the condition of bolts, rivets or welds connecting the gantry girder to the roof leg of the columns and the condition of rivets in gantry girder,
- v) the level and alignment of the gantry girders and gantry track,
- vi) the condition of the fasteners connecting the gantry rail to gantry girder,
- vii) the condition of welds in welded connection,
- viii) the condition of roof gutters and their fittings
- ix) the condition of Northlight glasses, roof sheets and their fittings,
- x) the condition of steel work in steel chimneys, and
- xi) the condition of paint.

#### **902. Joint inspection of structures in workshops**

The condition of gantry track, gantry girder and alignment of gantry track for overhead and jib cranes moving on rails should be jointly inspected by the Bridge Inspector and the Foreman/Crane Inspector as the case may be.

□□□

## CHAPTER - X

# INSPECTION AND MAINTENANCE OF TUNNELS AND DEEP CUTTINGS

## PART A - TUNNELS

### 1001 . Inspection by Engineering Inspectors

The Permanent way Inspector shall inspect every tunnel on his section once a year during the prescribed month after the monsoon season but where specified by the Chief Engineer, the structural part shall be inspected by the Works Inspector.

### 1002 . Items to be covered in the Inspection

The inspection shall cover :-

- a) Tunnel approaches and cuttings
- b) Portals at either end
- c) Tunnel walls, lining and roofing (lined and unlined)
- d) Drainage
- e) Refuges
- f) Ventilation shafts / Adits
- g) The section in relation to moving dimensions
- h) The track; and
- i) Lighting equipment and special tools with the maintenance gang.

### 1003. Record of Inspection

1. The Inspector / Inspectors shall record the results of their inspection in a manuscript register which shall contain particulars of date of inspection, condition of tunnel and approaches at the time of inspection and repairs carried out during the year. Two or three sheets may be allotted for each tunnel with the tunnel number, its length and kilometreage. The register should be in the form shown in Annexure 10/1.

2. The Inspector / Inspectors should promptly attend to the repair required.

3. The Inspector shall submit to the Assistant Engineer by the prescribed date a list of important defects with a certificate in duplicate to the effect.

“ I certify that I have personally carried out tunnel inspection of my section in accordance with standing orders for the year ending..... and append herewith a list of important defects.”

4. The Assistant Engineer shall issue such orders as deemed necessary to the Inspector and counter sign and forward one copy of the certificate of inspection to the Divisional Engineer with remarks if any.

5. The Inspector shall accompany the Assistant Engineer on the latter's Annual inspection of tunnels.

#### **1004. Inspection by Assistant Engineer**

1. The Assistant Engineer shall inspect every tunnel on the sub division once a year before the monsoon during the prescribed months and record the results in ink in the tunnel inspection register, Form Annexure 10/1.

2. The tunnels, the condition of which warrant special attention should be inspected more frequently.

3. The instructions and index as Annexure 10 /1 should be prefixed to each tunnel inspection register. Two or three sheets should be allotted for each tunnel so that a register may contain record of inspection over 10 to 15 years. The register should be printed using the standard proforma.

4. The inspection shall be detailed and cover all aspects, entries being made under each of the heads given in the register.

5. The Assistant Engineer should make an extract of all remarks concerning repairs required, send these to the Inspector / Inspectors with explicit instructions and ensure expeditious compliance.

6. On completion of his annual tunnel inspection , the Assistant Engineer shall certify at the end of the register as follows:

“ I certify that I have inspected all the tunnels shown in register during the year ending..... and have issued detailed orders in writing to the Inspectors concerned except the following on which the Divisional / Sr. Divisional Engineer's orders are solicited“. These registers should be in the Divisional / Sr.Divisional Engineer's office by specified date.

**1005. By Divisional / Sr. Divisional Engineers**

1. The Divisional/Sr. Divisional Engineers shall carefully scrutinise the Assistant Engineer tunnel inspection register and inspect such tunnels as called for his inspection. He shall record his orders regarding the points which require a decision by him and initial against every entry of tunnel in the registers in token of scrutiny. He should endorse on each register, below the Assistant Engineer certificate, as follows:

“ I have personally scrutinised this register and have issued orders regarding all essential points requiring a decision by me. The following points are submitted to the Territorial Head of the Department at Head Quarters for orders. “

2. The Divisional / Sr. Divisional Engineer should extract the items of inspection register requiring attention and send it to the Assistant Engineer who should intimate the same to the Inspector concerned for expeditious compliance.

3. The register should be forwarded to the Territorial Head of the Department at Headquarters who will examine each register, issue orders regarding matters referred to him, endorsing the registers to the effect and return them to the Divisional / Sr . Divisional Engineer. Subsequent action taken on the notes should be entered in the registers by the Assistant Engineer.

**1006. Mobile Staging for Inspection**

Requisite stagings mounted on the mobile units, such as open wagon, dip-lorry or rail motor, shall be used to carry out thorough inspection of the sides and roof of the tunnels. These should be kept at suitable points for urgent use as required.

**1007A. Details of tunnel inspection**

The details of inspection to be carried out are as follows

**1. Tunnel Approaches and Cutting :**

Normally the tunnel approaches will be in deep cuttings. The inspection of these cuttings should be carried out as detailed in paras 1010 to 1012 later in this Chapter.

## 2. Portals at either end :

During inspection it should be checked as to whether there are any signs of slips in the slopes above the portals; whether the masonry is in any way cracked, shaken or bulging and signs of movement are apparent. "Catch-water drains above the portals should drain away and not be allowed to percolate into the tunnel or behind the portal masonry.

Trees leaning or hanging on the slopes above the portals should be cut and cleared. Loose boulders, if any should be removed.

## 3. Section of tunnel in relation to moving dimensions :

It should be checked as to whether the dimensions of the tunnel section on straights and curves conform to the diagrams given in the Schedule of Dimensions.

Stagings mounted on mobile units will be helpful to check the profile.

## 4. Tunnel walls and roofing :

a) Lined section: During inspection it should be ascertained whether the lining is in a satisfactory condition. Seepage through joints in the masonry should be looked for.

Doubtful masonry should be tapped to detect 'drummy' places.

Cracks in the masonry should be marked by red paint, dated tell-tales placed at their extremities and serially numbered to detect extension.

Pointing of the masonry should be examined for its condition.

b) Unlined Sections: The unlined portions should be examined to find out whether they are sound.

Doubtful places, such as loose projections should be tapped and identified.

## 5. Drainage :

The drainage arrangements inside the tunnel and upto the outfall should be inspected. It should be ensured that the side drains are adequate and function satisfactorily. The drains should be periodically cleaned.



#### 6. Tunnel refuges :

It should be checked up as to whether these are well maintained and free of vegetation and other growth.

#### 7. Ventilation shafts / Adits :

It should be ascertained whether these are adequate and maintained free of vegetation and other growth . For tunnels more than 200m long, level of pollution and temperature condition should be enquired from the gang and Keyman working in that location of tunnel keeping in view passenger comfort and working conditions for working inside the tunnel.

#### 8. Lighting equipment and special tools :

The lighting equipment and special tools where supplied should be in a state of good repair.

Sufficient spare tools should be stocked.

#### 9. The Track :

The track should be examined for good line and level including the approaches.

Rails, sleepers and fastenings should be particularly examined for corrosion, inside the tunnels.

Level pillars and reference marks indicating the correct level and alignment shall be checked periodically. Renewals should be carried out as and when required on high priority.

### **1007B. Ventilation of Tunnels**

#### **i) General:**

Ventilation of tunnel is one of the important aspect related to passenger and crew comfort during passage of train inside the tunnel. It is also important for workmen working inside the tunnel from their health point of view. Movement of trains inside tunnel, transforms its environmental features. Some of the pollutant gases emitted from locomotives, may be potential hazards to the health, physiological and psychological comfort of human being. For safe operation, it is necessary that these hazardous features especially gases emitted from

locomotives, should not cause discomfort to crew, passenger and workman inside the tunnel. Concentration of pollutant gases (i.e. NO, NO<sub>2</sub>, CO, CO<sub>2</sub>, SO<sub>2</sub> and hydrocarbons etc.) and rise in temperature of air inside tunnel depends upon effectiveness of ventilation in tunnel. Thus, it is necessary that tunnels are provided with adequate ventilation, so that concentration of hazardous gases and rise in temperature of air inside tunnel remain within permissible limits.

ii) **EFFECT OF MOVEMENT OF TRAIN INSIDE TUNNEL:**

The passage of a train in a tunnel transform environmental features and create the following environmental hazards:

a) **Air Quality Deterioration:**

Emission from diesel locomotive contains potentially hazardous gases such as oxides of nitrogen (NO, NO<sub>2</sub>), oxides of carbon (CO, CO<sub>2</sub>) Sulpherdioxide and hydrocarbons. These gases are emitted from top of locomotive and get mixed up with the air available inside tunnel and pollutes it. Part of polluted air descends, to the lower part of the tunnel. High concentration of carbon monoxide gases causes headache and discomfort and may be fatal if stay is prolonged. Nitrogen Oxides (NO, NO<sub>2</sub>) have toxic effects. Sulpherdioxide is bronchial and nasal irritant. In short, pollutant gases emitted by locomotive may prove to be hazardous, if their concentration exceeds permissible value.

b) **Thermal Environment Hazards**

As a locomotive traverses through a tunnel, heat from exhaust gases and other part of locomotive, is emitted. The air inside the tunnel gets heated up due to heat emitted from exhaust gasses/locomotive surface. For safe operation of the trains in the tunnel, the thermal environment is to be controlled within a safe range for efficient functioning of locomotive and comfort of passsengers, crew and workman.

c) **Pressure Transient Hazards**

When a train passes through a tunnel, aerodynamic effects come into play. Due to this, the drag and propulsion power increases and the

pressure environment around the train gets changed. The change of pressure environment around the moving vehicle may cause severe discomfort to passengers.

iii) **PERMISSIBLE VALUES OF POLLUTANTS:**

Limits are required to be set for the various pollutants inside tunnel to ensure safety and health of passengers, crew and workmen. The permissible values for the concentration of pollutants in tunnels depend upon the time of exposure. These values shall be different for workers who are supposed to work for 8 hours inside tunnel and for passengers and crew who are supposed to pass the tunnel within few minutes, depending upon the length of the tunnel and speed of the train.

Threshold level for various pollutants are given in **Table-10.01**. As workers are required to remain in tunnel for 8 hours, values for 8 hours exposure need to be considered for the design of ventilation system. Maximum temperature of air inside tunnel needs to be limited to 50°C considering passengers and workmen comfort.

**TABLE 10.01**

THRESHOLD LEVELS FOR POLLUTANTS INSIDE TUNNELS

Pollutant Gas	8 hours exposure values	15 minutes exposure values*
CO	50 ppm	400 ppm
NO	25 ppm	35 ppm
NO <sub>2</sub>	5 ppm	5 ppm
CO <sub>2</sub>	5000 ppm	18000 ppm
SO <sub>2</sub>	5 ppm	5 ppm

\* These values are from the consideration of passengers comfort and shall depend upon the length of the tunnel and speed of the train.

**iv) TYPES OF VENTILATION SYSTEMS:**

The ventilation in a tunnel can be achieved by:-

**(a) Natural Ventilation :**

When a train traverses inside tunnel at a relatively high speed and ratio of train frontal area to tunnel cross section is of the order of 0.5 to 0.6, it induces considerable air flow inside tunnel. This type of ventilation is called as natural ventilation. The amount of induced air flow will depend upon orientation of tunnel and atmospheric pressure difference between inside and outside the tunnel. Quantum of induced air flow will be more in tunnels laid parallel to prevailing wind and having exposed approaches as compared to tunnels sheltered from prevailing wind. Thus this aspect needs to be considered at the time of deciding orientation of tunnel. However limitation imposed by terrain and track geometry parameters may not make it feasible in every case. If length of tunnel is small, the induced air flow may be sufficient to keep the pollutants concentration and rise in temperature inside tunnel, within permissible limits. In such case there may not be any necessity for provision of artificial ventilation.

**(b) Artificial Ventilation:**

In long tunnels induced air flow due to train movement is not sufficient to keep concentration of pollutant gases under permissible limit inside tunnel. In such cases artificial ventilation may have to be provided by means of provision of ventilation shafts with or without provision of electric fans, with suction and delivery arrangement. Where provision of shaft is not feasible, longitudinal ventilation with the help of an axial blower fan at the portal supplemented by auxiliary fan of smaller capacity, spaced at suitable intervals along the length of tunnel may be considered.

**v) DESIGN OF VENTILATION SYSTEM OF TUNNELS**

v(i) The essential requirement of a ventilation system of tunnel are as under:

(a) It should ensure, sufficient airflow relative to moving train, to keep the concentration of pollutant gases inside tunnel within permissible limits.

(b) It should ensure sufficient air flow to prevent locomotives from over-heating and to keep thermal effects within desirable limits.

(c) It should ensure that pressure transient are within acceptable limits.

V(ii) The amount of air flow and type of ventilation arrangements required depend upon the level of concentration of pollutants and maximum temperature likely to be attained inside tunnel due to movement of trains. Level of concentration of pollutants and maximum temperature likely to be attained inside tunnel depends upon the following factors:

i) Type of locos. (ii) Gradient inside tunnel (iii) Length of train (iv) Speed of the train (v) Time interval between two trains (vi) Ambient temperature (vii) Length of tunnel (viii) Cross section of tunnel (ix) Direction of prevailing winds etc.

V(iii) As large no. of factors are involved, it may be difficult to estimate pollutants concentration & maximum temperature likely to be attained analytically. Thus mathematical modeling and simulation studies are necessary for design of ventilation system. As factors governing designs of ventilation system vary considerably from site to site, therefore design for ventilation of each tunnel has to be developed separately.

V(iv) Normally on single line sections, tunnels having length upto 2 kms, may not require provision of artificial ventilation but it should be ensured that levels of concentration of pollutants during passage of trains are not likely to exceed threshold levels. Tunnels having length more than 2 kms may require provisions of artificial ventilation, by means of shaft with or without provision of fans, depending upon results of simulation studies.”

**1008. Leakage in tunnels and methods of correction**

## 1. General :

1.1 Water leakage occurs in most of the old tunnels. It is one of the most aggravating and difficult problems detrimental to tunnel linings and contributing to muddy track.

1.2 Water leakage usually occurs near the portals or where the depth of cover is less. Underground streams or springs may contribute to leakage anywhere in the tunnel. Water following an impervious strata of material may also seep out.

1.3 Leaks generally occur at construction joints; cracks that have developed in the lining, honey combed sections of concrete and joints of brick or stone lining. Seepage in brick lined tunnels may be examined carefully as they may cover extensive area.

1.4 Weep holes often fail to function because of their small diameter or their being blocked by mineral deposits or talus piling up at the back of the wall . This holds up the water behind the lining which is relieved by the development of seepage and leads to leakage through the tunnel lining. Old shafts used in construction may be source of seepage of water.

## 2. Correction of leakage in tunnels :

2.1 For masonry lined tunnels it is best to bring the water through proper drains into the ditch rather than try to seal the water at the back of the tunnel lining. Attempts should be made to open existing weep holes and drains. However, where this is not feasible, new weep holes and drains should be made.

Holes should be drilled through the tunnel lining at the wet areas to tap the water.

2.2 The holes should be drilled as near the drain level as possible, depending on the height of the seepage points and spaced at suitable intervals.

2.3 Construction joints or cracks where seepage is light may be sealed by chipping the crack in the form of a "V" and caulking with lead wool and by guniting.

2.4 Where seepage in joints or cracks is too great to seal or a definite leak occurs, water should be carried in recessed drain to the side drain level. A series of holes should be drilled in the recessed drain channel through the tunnel lining to offer an easy path for escape of water. The face of the drain may be of brick or shotcrete.

2.5 Very often, leaks around the portals are due to poor drainage over the portal. This may be due to clogged portal drains and/ or weathered material forming a catch basin over the portal. Generally it is best to open portal drains and clear the drainage ditches above the portal.

### **1009. Works connected with the maintenance of tunnels**

All works in tunnels should be carried out under the protection of engineering signals. The Inspector concerned shall be responsible for the safety of trains and of the men and equipment.

Mobile testing units shall be used under block protection.

## **PART B - DEEP CUTTINGS**

### **1010 : General**

Deep cuttings exist on the approach of tunnels and in ghat sections. At deep cuttings, traffic may be interrupted by slips or boulders dropping from the hill sides.

### **1011. Inspection Register of Vulnerable Cuttings**

Each Divisional Engineer/Sr. Divisional Engineer should identify the vulnerable cuttings in the various sections. A register for these cutting should be maintained in the proforma given in Annexure 10 /2. Separate page will be maintained for each cutting.

#### **2. Inspection of Deep Cuttings :**

2.1 Immediately after the monsoon, the PWI should inspect each cutting and record his observation in the register which should be sent to the AEN for his examination well before the next monsoon to enable for planning of remedial measures that he may like to take in the intervening period.

2.2 Each vulnerable cutting should be inspected before the onset of rains as in the case of bridges and tunnels by the AEN concerned and

he should record his remarks in the register which should then be sent to the PWI for taking appropriate action . Action taken by the PWI should be recorded in the register and the same returned to the AEN for his perusal before the onset of the monsoon. Date by which these registers should be returned to the AEN for his perusal to enable that adequate action has been taken should also be specified by the Divisional Engineer depending upon the time when the monsoon starts in a particular section.

2.3 During monsoon, frequent inspection of vulnerable cuttings may be carried out as required keeping in view the past history and the vulnerability of the cutting.

### **1012 Points to be noted during inspection of cuttings**

1. During the inspection of cuttings, the inspecting official should look for signs of upheaval in the regular slope surface of cuttings which would indicate that there are water pocket underneath the cutting slopes.

2. The official should examine weather catch water drains have been provided to intercept water from running down the hill side and getting into the cutting. He should see that the catch water drains are clear of all obstructions and ensure that there are no depressions in the longitudinal level of these drains which could collect storm water and may cause slips. He should check that the catch water drains have a good longitudinal slope towards the outfall.

3. He should examine carefully for any loose boulders on top of cutting and side slopes which are likely to fall and are in precarious position.

4. He should examine

- i) the condition of rubble pitching on the slopes, if any,
- ii) the condition of retaining walls and the weep holes,
- iii) the condition of side drains and see that they are not choked up.

5. He should see whether any tree is precariously perched on the top of cutting and slopes.



**1013. Action to be taken in the case of boulder drops**

1. In case of boulder drops, the boulder may be removed by jacking. If the boulder cannot be moved by jacks or levers, blasting will be necessary.

2. Inspectors who will handle blasting equipments should be conversant with the methods of blasting and should be familiar with all safety precautions to be observed for the custody and use of explosives.

3. The following equipment should be kept at the Head quarters of each Inspector in whose section such vulnerable cutting exist:

- i) Jacks in good working condition ,
- ii) Jumping steel bars 1"dia and 5' long,
- iii) Charging rods and
- iv) Suitable stock of explosives, fuses and detonators at specified places.

**1014. Action to be taken after inspection of cutting**

1. Action should be taken to remove boulders in a planned manner as referred to in para above.

2. Action should be taken to clear and repair catch water drains and side drains as necessary.

3. Trees perched at top and side slopes of cuttings should be removed.

4. Provision of retaining walls as necessary to be made.

**1015. Guarding of Vulnerable Cuttings**

Stationary watchmen should be posted round the clock at nominated vulnerable cuttings during the monsoon period in accordance with para 1014 of Indian Railway Permanent way Manual 1986.

□□□

## CHAPTER - XI

### INSPECTION OF BRIDGES

#### 1101. By Permanent Way And Works Inspectors

##### 1. Details of inspection :

Different Railways follow different practices in regard to the responsibility of annual inspection and maintenance of bridges. The inspection of the items in para (a) below should be carried out by Inspector of Works or P. Way Inspector as per the practice or as approved by the Chief Engineer of the Railway.

##### a) By Way/Works Inspectors :

Once a year during the prescribed months prior to the monsoon season, the Inspector shall inspect every bridge including road under/over bridges in his section. The inspection shall cover the following :

- i) Foundations and substructures,
- ii) Protective works
- iii) Superstructures of all RCC, PSC slab and masonry bridges,
- iv) Detailed inspection of steel works of girders less than 12.2 m clear span once in five years, about 20% being done each year,
- v) General condition of superstructure of all other types of bridges and their bearings,
- vi) Obstruction of waterways.

##### b) Specifically by Permanent Way Inspectors :

Once a year during the prescribed months prior to monsoon, the Permanent Way Inspector shall inspect the following :

- i) the track and approaches of all the bridges,
- ii) run off frames if any and foot path on bridges.

##### 2. Record of Bridge Inspection :

a) The Inspectors shall record results of their inspection in a register in manuscript form which shall contain particulars of the date of inspection, the condition of the bridge at the time of inspection and the repairs carried out during the year. Sufficient sheets may be allotted for each bridge so that at least ten years records can be contained in one register (Refer Annexure 11/11)

**b) Certificate of Inspection :**

The Inspector shall submit to the Assistant Engineer by the prescribed date a certificate in duplicate to the effect "I certify that I have carried out pre-monsoon bridge inspection of my section in accordance with standing orders for the year....and append herewith a list of important defects, for which your instructions are requested.'

The Assistant Engineer shall issue such orders as deemed necessary to the Inspector, countersign and forward one copy of the certificate of inspection to the Divisional Engineer with remarks, if any, within a month. The Inspector should carry out repairs as early as possible.

**1102. By Bridge Inspectors****1. Details of inspections :**

The Bridge Inspector shall inspect in detail :

- a) The steel work and bearings of all girders 12.2 m clear span and above including that of road under/over bridges once in five years, about 20% of the inspection being carried out every year.
- b) Welded girders once in three years, the initial inspection being carried out one year after installation.
- c) Superstructure of all prestressed concrete bridges, composite girder bridges once in five years, the initial inspection being carried out one year after installation.
- d) Girders which are overstressed and kept under observation at least once a year.
- e) Floor system of early steel girders once in a year. Other members once in five years.

**2. Registers to be maintained by the Bridge Inspectors :**

The following registers should be maintained by the Bridge Inspector:

- i) Inspection register for steel work in bridges (Annexure 11/1 and 11/2)

- ii) Rivet Testing Register (Annexure 11/13)
- iii) Weld Test Register,
- iv) PSC Bridge / Composite Girder Bridge Inspection Register,
- v) Annual Inspection Register for overstressed girder.

3. Certificate of inspection :

Notes of inspection should be recorded in the register maintained. The registers should be submitted to the nominated Engineer in charge of bridges by a specified date. Certificate should be appended in the register to the effect "I certify that I have inspected the bridges scheduled for inspection during that year in accordance with the standing orders for the year ending December .... and append herewith a list of items for which instructions are requested."

All defects which can be rectified by the Bridge Inspector should be attended to. Repairs beyond the scope of the available facilities of the Bridge Inspector must be reported by him to the nominated officer with a copy to the Divisional Engineer.

### **1103. Inspection By Assistant Engineers**

1. Details of inspection :

a) The Assistant Engineer shall inspect every bridge including road over / under bridges once a year after the monsoon. The inspection should commence soon after the cessation of the monsoon and completed by a date to be specified by the Chief Engineer.

b) Bridges, whose condition warrants special attention should be inspected more frequently.

c) The Assistant Engineer along with his counter part of the PWD or Irrigation Department of the State Government shall jointly inspect canal and irrigation crossings, wherever necessary.

d) The inspection shall in detail cover all aspects as detailed in Para 1107. In regard to steel work, the general condition of the girders and bearings should be examined paying special attention to places liable to corrosion and stress concentration (in welded girders) and the condition of paint.

e) Scaffoldings or cradles as may be required for the purpose of detailed inspection should be arranged.

## 2. Bridge Inspection Register :

The Assistant Engineer should record the results of his inspection in ink in the Bridge Inspection Register, separate registers being maintained for major and minor bridges. For each one of the important bridges and river training works there to be specified by the Chief Engineer, a separate Bridge Inspection Register should be maintained.

3. (a) Important bridges are those having a linear waterway of 300 metres or a total waterway of 1000 Sqm or more and those classified as important by the Chief Engineer / Chief Bridge Engineer, depending on considerations such as depth of waterway, extent of river training works and maintenance problems.

b) A major bridge is one which has a total water way of 18 linear metres or more or which has a clear opening of 12 linear metres or more in any one span.

c) Bridges which do not fall in these classifications are termed as minor bridges.

## 4. Proforma of Bridge Inspection Register.

### a) Important and major bridges :

These bridge registers will contain :

- i) instructions to the inspecting official (Annexure 11/3),
- ii) index of bridges (Annexure 11/4),
- iii) general key plan (Annexure 11/5)
- iv) classification of structures (Annexure 11/6)
- v) inscription plaques on bridges showing nature and depth of foundation (Annexure 11/7)
- vi) proforma for recording details of each bridge (major and important) (Annexure 11/8)
- vii) proforma for entering condition of each major and important bridge at the time of inspection (Annex 11/9)

### b) Minor bridges :

- i) these bridge registers will contain items a (i) to (v) above,
- ii) proforma for recording the details of each bridge (Annexure 11/10)

iii) proforma for entering the condition of each minor bridge at the time of inspection (Annexure 11/11)

**Notes :**

\* Details shown in sub-para (a) item (i) to (v) and (b) item (i) should be printed in the top leaves of the register.

\* Sufficient sheets should be allotted for each bridge so that the register may contain the record of inspection over 10 to 15 years.

\* All Old bridge registers must be preserved as a permanent record for reference.

5. Instructions for making entries in the register.

a) Under each heading entry should state clearly whether the previous year's notes have been attended to.

b) Entries in the column "Condition of the bridge at the time of inspection" should be in the nature of statements. A defect once mentioned should not be omitted in future years unless it has been eliminated by rebuilding or strengthening or repairs, in which case a note should be made to that effect. In addition, details as described in para 1103 relating to Numerical Rating System, should be recorded in the relevant columns in the register.

c) In the column "Action taken" the remarks should be in the form that orders have been issued, e.g.

i) Permanent Way Inspector instructed to renew sleepers,

ii) Bridge Inspector instructed to carry out painting.

d) No bridge which is cracked or in which the masonry is shaken, crushed, bulging, deteriorating or showing signs of movement or in which the steel work is affected should be described as "sound".

e) A bridge is to be noted as "requiring special repairs" when the whole or any part of it has to be rebuilt or undergo heavy repairs.

6. Numerical Rating System (NRS) :

a) The "Numerical Rating System" for bridge inspection assigns a "Unique Rating Number" (URN) to represent the physical condition of a bridge. Lower the URN more serious is the deteriorated condition of a bridge. The system thus helps in identifying progressive deterioration in the condition of a bridge. URN can be stored in a computer for quick retrieval and fixing priorities for repairs or rehabilitation.

b) The URN of a bridge is arrived at based on the condition of components and a "Condition Rating Number" (CRN) assigned to each of them. The various components of a bridge in sequence, are :

- i) foundations and flooring, if any,
- ii) masonry / concrete in substructure,
- iii) training and protective works, if any,
- iv) bed blocks,
- v) bearings and expansion arrangements,
- vi) superstructure - Girders / Arch / Pipe / Slab etc.
- vii) track structure.

c) The CRN is allotted to each of the above components based on their condition at the time of inspection, using the following scale:

<b>Condition RatingNo. (CRN)</b>	<b>Condition of bridge component</b>
1	A condition which warrants rebuilding / rehabilitation immediately
2	A condition which requires rebuilding / rehabilitation on a programmed basis
3	A condition which requires major / special repairs
4	A condition which requires routine maintenance
5	A sound condition
6	Not applicable
0	Not inspected

d) When any component in a bridge is more than one in number CRN is assigned to each of them and the lowest value used. For example, if a bridge has five piers and two abutments, and these are given the CRN of 5,4,3,2,5,5,4 then the CRN for the substructure component of the bridge would be minimum of the above, i.e. 2.

e) If in any bridge, one or more components do not exist, the CRN for such components shall be shown as 6.

f) From the CRNs for different components of a bridge, an overall Rating Number (ORN) for the bridge as a whole is then given. The ORN is the lowest of the seven CRNs of a bridge, except 0.

g) For a major bridge, the URN would comprise of eight digits, the first digit indicating the ORN and the following seven digits the CRNs of each of its above seven components in sequence.

For example URN 20362544 of a major bridge would indicate the following :

Digit No.	Value	Indication
1	2	Whole bridge or one or more of its components require (s) rebuilding / rehabilitation on a programmed basis
2	0	Foundation and flooring were not inspected
3	3	Substructure requires major / special repairs
4	6	Not applicable, i.e. the bridge does not have any training or protective works
5	2	Bed blocks are cracked and shaking
6	5	Bearings and expansion arrangements are in sound condition
7	4	Superstructure requires routine maintenance
8	4	Track structure requires routine maintenance.

h) URN of a minor bridge shall be represented by its ORN only, i.e. by a single digit to indicate its overall condition using the guidelines contained in Sub-para (c).

j) The physical condition of a road over bridge is to be represented as for a rail bridge.

k) The CRN of different components of a bridge as evaluated above shall be entered in the "Box" to be provided in the register at appropriate places.

7. Follow up of Inspection Notes by Assistant Engineer.



a) The Assistant Engineer should make an extract of the orders under "Action taken column" and send the same to the Permanent Way Inspector / Inspector of Works / Bridge Inspector concerned for compliance with a copy to the Divisional Engineer. Arrangements should be made to carry out the repairs as soon as defects are noticed without waiting for the completion of inspection of other bridges.

b) If it is not possible to make complete inspection of any bridge owing to the presence of standing water, the fact should be so stated. The inspection of foundations should be made no sooner water dries up or conditions make it possible to do so and results recorded as supplementary entries in the register.

c) All the bridge components which have Condition Rating Number (CRN) as zero should be inspected by the Assistant Engineer at the earliest.

#### 8. Certificate by the Assistant Engineer

a) On completion of his annual bridge inspection, the Assistant Engineer shall certify at the end of the register as follows :

"I have personally inspected all the bridges shown in this register during the year ending December.... and have issued detailed orders in writing to the Inspectors concerned, except the following.

Bridge No..... are referred to for further orders. Bridge No..... have one or more CRN as 0 during more than one consecutive inspections".

All registers should be sent to the Divisional Engineer by a specified date. They may be sent in a regular flow as and when bridge inspection on a section is over without waiting for the completion of inspection of all the bridges.

**Note** : Divisional Engineers include such Sr. Divisional Engineers who have same duties as that of Divisional Engineer in a Division.

### **1104. By Divisional Engineers And Territorial HODs**

#### 1. Details of inspection :

a) The Divisional Engineer shall carefully scrutinise the Assistant Engineer's Bridge Inspection Register and inspect all important bridges and such bridges as called for his inspection. He shall record his orders regarding the points which require as decision by him and initial against every bridge in token of scrutiny.

b) He will complete his inspections and scrutiny by a specified date.

2. Certificate by Divisional Engineer.

He should endorse on each register, below the Assistant Engineer's certificate as follows:

"I have personally scrutinised this register and inspected all important bridge and bridges referred to me and have issued orders regarding all essential points requiring a decision by me. The following points are submitted to the Territorial Head of the Department for orders.

Bridge No (s) \_\_\_\_\_ require rehabilitation.

Bridge No (s) \_\_\_\_\_ have ORN 1 or 2

Bridge No (s) \_\_\_\_\_ have one or more CRN as 0  
for more than one consecutive

inspection."

3. The Divisional Engineer shall inspect all those bridges for which the ORN is 1,2 or 3 and revise/confirm the rating given by the AEN. Bridges which have, after review, an ORN of 1 shall be placed in the distressed category.

4. Action by Divisional Engineer:

He should then send the register to the Assistant Engineer for noting his orders with instructions to return them within ten days. The Assistant Engineer should then extract the orders issued by the Divisional Engineer, intimate the same to the Inspectors concerned and ensure expeditious compliance.

5. Scrutiny by Territorial HOD and action thereon :

The registers should then be forwarded by the Divisional Engineer to the Territorial HOD by a specified date, who will examine each register, issue orders regarding matters referred to him duly endorsing the registers to the effect and return them to the Divisional Engineer latest by a specified date. Subsequent action taken on the Territorial HOD's orders should be entered in the register by the Assistant Engineers.

**1105. By Assistant Engineer / Divisional Engineer (Bridge).**

1. The officer nominated for the purpose of maintenance and inspection of steel work of bridges shall scrutinise the registers sent by Bridge Inspector and endorse the registers below the Bridge Inspector's certificate and forward it through the concerned Divisional Engineer by a specified date to the Dy. Chief Engineer/ (Bridges) nominated by Chief Bridge Engineer.

2. He will inspect:

- a) Bridges which have been referred to him,
- b) Bridges which call for the inspection after scrutiny of the Bridge Inspector's registers, and
- c) All the overstressed girders where camber loss is noted.

3. He will test check 10% of the inspection work carried out by the Bridge Inspector.

4. Certificate of Inspection:

After scrutiny of the registers and inspection of bridges the nominated officer will append a certificate on each register to the effect:

"I certify that I have personally scrutinised this register and issued instructions on essential points requiring a decision by me.

I have carried out test checks as required during the year and the following points are referred to the Dy. Chief Engineer/ (Bridges) for orders".

**1106. By Dy. Chief Engineer / (Bridges)**

1. Scrutiny of the register :

The nominated Dy. Chief Engineer (Bridges) shall examine the entries in the Bridge Inspector's register and record his orders on the points referred to him by the Divisional Engineer (Bridges) / Assistant Engineer (Bridges).

The registers should be returned by a prescribed date with necessary endorsements to the Bridge Inspectors through the nominated officer for taking prompt action thereon.

**2. Details of Inspection :**

He shall inspect the steel work of such bridges,

a) as called for his inspection after scrutiny of the registers.

b) as directed by the Chief Bridge Engineer and enter his notes and ensure prompt action thereon.

He will list out the defects considered sufficiently important and bring them to the notice of the Chief Bridge Engineer through the Territorial HOD.

**DETAILS OF BRIDGE INSPECTIONS****1107. The Detailed Inspection Of A Bridge Includes Examination of****1. Flooring and foundations :**

a) To ascertain whether:

i) scour has taken place particularly around the piers and near abutments and also along curtain walls and down stream of drop walls,

ii) there is any settlement or undermining of the foundations.

b) The conditions of the flooring, drop walls, curtain walls, apron and pitching should be examined.

c) At specified bridges soundings should be taken during floods vide instructions contained in para 711.1 and annual survey of scour holes vide para 712.2

**2. Masonry in substructure:**

a) To ascertain whether:

i) the masonry is in any way cracked, shaken or crushed, particularly under the bed blocks in the ballast walls, abutments and piers,

ii) there is any bulging, shearing, tilting (out of plumb) and apparent signs of movement in abutments, wing and return walls,

iii) there is any deterioration due to weathering or any damage to the stone or brick or leaching of the mortar in the joints.

b) Seepage of water through the joints in the masonry should be looked for. Brick masonry and other soft stone should be tapped with a light hammer for detecting "drummy" places.

c) Cracks in the masonry must be marked by red paint for their entire lengths and dated tell-tales placed at their extremities and numbered. This will enable cracks to be readily located and any extension detected. Where extensive cracks are noticed, sketch of the cracks should be kept in the Bridge Inspection Register with the details like length, depth, width, location, etc.

d) Under-water substructure inspection:

The substructure of the bridges which are normally under water should be inspected by adopting suitable methods which may include engaging of divers and special equipment.

e) In the case of arch bridges, the following points may be examined during inspection :

- i) longitudinal cracks (cracks parallel to the direction of traffic) in arch barrel, due to settlement below,
- ii) horizontal crack and bulging of spandrel wall.
- iii) sliding forward of spandrel wall,
- iv) transverse or diagonal cracks in arch intrados which may or may not be accompanied by crushing of bricks, or stone masonry,
- v) Cracks in the vicinity of the crown of the arch,
- vi) leaching out of mortar,
- vii) weathering of masonry,
- viii) loosening of key stone and voussoirs of arch,
- ix) adequacy of cushion,
- x) adequacy of weep holes and drainage,
- xi) presence of cracks in parapet wall/leaning of parapet wall.

3. Protective works and water ways:

a) To ascertain whether :

- i) the protective works such as pitching, toe wall, flooring, drop/curtain walls, guide bunds, launching aprons, spurs/groynes, approach banks, marginal bunds, are in sound condition and adequate,
- ii) the waterway is adequate and clear of obstruction,
- iii) the pitching reserves as per schedule are available and are adequate.

b) The marginal embankments maintained by the State Governments should be inspected and deficiencies noticed advised to concerned authority.

c) It should be examined whether there has been any disturbing influence noticed like excessive velocity, parallel flow, heavy afflux, tank bursts in catchments and increase in spill from adjacent catchment.

#### 4. Girder alignment and seatings:

a) To ascertain whether:

- i) the position of girders in respect of line and level relative to the piers and abutments is correct,
- ii) the bearings are fully and evenly seated on the bed blocks and the holding down bolts are in position and anchored in the bed blocks,
- iii) the bed blocks are cracked, crushed, shifted or shaken, particularly under the bearings,
- iv) the rollers and the sliding plates provided at the expansion ends to permit expansion and contraction are well greased, free of dust and working freely,
- v) the date of lubrication of girder bearings is conspicuously painted,
- vi) the metal bearings are cracked or corroded,
- vii) bed timbers where provided, are crushed or decayed,
- viii) the elastomeric bearings are cracked or are showing signs of excessive deformation beyond the normal visible corrugations,
- ix) the bearings provided with oil bath are covered free of dust and proper oil level is maintained.

b) Where possible, girders should be observed under train load for any abnormal movement or evidence of settlement. If a girder lifts off its bearings and "hammers" this must be specially reported.

#### 5. Structural condition of girders:

- a) To ascertain whether the structural condition is satisfactory.
- b) In triangulated spans, the following points should be observed:

- i) loss of camber in the main girders assessed from comparative readings,
  - ii) distortion of members,
  - iii) high incidence of loose rivets.
- c) The following girder members should be examined for distortion:
- i) bottom chord members especially the unbraced sections near the ends of the span,
  - ii) top chord members with insufficient restraint by bracings,
  - iii) diagonal web members and tension members made up of flats,
  - iv) top flanges of plate girders.
- d) (i) To ascertain tightness of rivets by a sample test, the rivets are to be tested as per the procedure outlined in Annexure 11/12. Rust streaks close to rivets usually denote looseness,
- ii) In the case of plate girders, loose and distorted rivets should be looked for at the connections of the main angles to the web plates below the sleepers and also at the ends of the girder.
  - iii) In triangulated spans field rivets should be examined at end connections of stringers to cross girders, cross girders connections to main girder, end connections of cross and lateral bracings, and chord joints and web member connections.
- e) To ascertain whether inspection gangways have been provided on triangulated girder spans, where necessary.
- f) In the case of welded girders, the girders shall be inspected over the entire length. Some of the weld details and critical locations, which should be given special attention during the inspection are:
- i) butt welds in tension flange or tension member,
  - ii) welds at ends of transverse and longitudinal stiffeners and welds of attachments to web and tension flange or tension member,
  - iii) ends of welded cover plates,
  - iv) intersecting weld,
  - v) locations having sudden change in cross section or configuration leading to stress concentrations,
  - vi) re-entrant corners and copes

- vii) weld repairs and tack welds
  - viii) visible notches such as flame cut edges and mechanical indentations,
  - ix) splice joints,
  - x) bracing and cross frame connections with stiffeners,
  - xi) connections transmitting heavy torsional or in plane moments to members, i.e. stringer to cross girder and cross girder to main girder connections,
  - xii) ends of welds and weld craters,
  - xiii) unusual type connections,
  - xiv) bearings and their connections,
  - xv) members damaged or bent during transit, erection or in service,
  - xvi) structural details which are known to have exhibited fatigue problems on other bridges,
  - xvii) locations having corrosion, pitting, etc. and loss of section.
- g) In case of composite girders the junction between concrete slab and steel girder shall be inspected for:
- i) shear connector and girder connections,
  - ii) any vertical separation between girder and slab and also the critical locations mentioned in sub-para 5(f) as applicable to the composite girder.
- h) In the case of overstressed girders, the joints where the stresses in rivets in shear and bearing as per stress sheets are higher than the permissible working stresses should be examined.
6. The condition of steel work :
- a) Action may be taken to ascertain whether the condition of paint is satisfactory and that no corrosion is taking place.
  - b) The following part of steel work which are prone to corrosion should be specially examined.
    - i) where water is likely to collect or parts where alternate wetting and drying can take place,
    - ii) where longitudinal timbers are carried in channel stringers and in the troughing of ballasted deck,



- iii) steel work of girders and the under side of over bridges which are liable to corrosion by the action of fumes from engines and whether they are protected by smoke guards,
- iv) seatings of wooden floors or treads of foot over bridges,
- v) steel column footings of over bridges where buried in ground,
- vi) around bearings of girders where debris can collect,
- vii) inaccessible parts of structures like the inside of box girders with insufficient clearance between the flanges and behind bends of joggled stiffeners.

c) It is difficult to detect cracks in steel work as they are likely to be covered by a film of paint or corrosion and a careful inspection is necessary for their timely detection.

Locations which must receive attention are :

- i) roots of flanges and angles where defects in rolling can initiate cracks,
- ii) joints where heavy shear is transmitted,
- iii) badly corroded members,
- iv) bent plates, if shaped at an inadequate and low temperature and subjected to heavy and repeated dynamic loads.

d) Steel work in wrought iron or manufactured before 1905 (i.e. early steel) requires greater attention in regard to the existence of cracks.

e) Once cracks are detected, their likely cause should be investigated. If the investigations indicate certain deficiencies, girders of the same design and vintage must be closely examined at corresponding locations.

7. Track on the bridge approaches :

The following points should be kept in mind while inspecting the track on the bridge proper :

- a) General condition of track :
  - i) it should be ascertained whether it is central to the rail bearers and the main girders are in good line and level,

- ii) departure from line is caused by incorrect seating of girders, shifting of girders laterally or longitudinally, incorrect seating of sleepers on girders and rails on sleepers, varying gauge or creep.
- iii) departure from level is caused by errors in level of bed blocks or careless sleepers. The adequacy of clearances of running rails over ballast walls or ballast girders at the abutments and the condition of timbers and fastening on the run off and skew spans should be checked.

b) Sleepers : The condition of sleepers and fastenings should be checked. The spacing of sleepers should not exceed the limits laid down in para 273 (1) and 273 (3) of IRPWM-1986. Squareness of sleepers shall be ensured. Sleepers requiring renewals should be marked with paint, and renewals carried out. End bolts should be provided on sleepers which have developed end splits.

c) Hook bolts : Hook bolts should be checked for their firm grip. Position of arrows on top of the bolts should be at right angles to the rails pointing towards the rail. Hook bolts should be oiled periodically to prevent rusting.

d) Creep and joint gaps should be checked and rails pulled back wherever necessary. Rail fastenings should be tight. Defective rails should be replaced. Where switch expansion joints are provided on the girder bridge, it should be ensured that free movement of the switch is not hindered.

e) Guard rails :

- i) adequacy of guard rail arrangements should be checked,
- ii) correct distance between the running rails and the guard rail and the clearance of guard rails over the ballast walls should be checked,
- iii) correct flaring and burial at the ends of the guard rails should be examined.
- iv) wooden block, where provided, should be examined for their soundness,

v) it should be checked whether angle iron/tie bar runners and foot walk are provided and fixed properly.

f) The gauge and level of track should be checked.

g) Track on approaches :

The following points need attention, while inspecting the approaches of the bridge :

i) track geometry on the approaches should be maintained to the best possible standards,

ii) rail joints should be avoided within three metres of a bridge abutment,

iii) the condition of the ballast wall should be checked,

iv) full sections of ballast should be maintained for atleast 50 metres on the approaches. This portion of the track should be well anchored.

h) Rail joints : It should be checked whether any rail joint is existing on girder bridges of 6.1 m span and less and on arch bridges having insufficient cushion. In the case of bridges consisting of two or more spans, the rail joints shall be placed as far as practicable over the piers.

8. Trolley and safety refuges :

Trolley refuges should be checked to ascertain :

a) Whether these are structurally in good condition.

b) Whether they have been provided :

i) on bridges with main span of less than 100 metres, at every 100 metres,

ii) on bridges with main spans of 100 metres and more, a refuge over each pier.

9. Foot paths :

a) To ascertain whether the foot paths are properly supported.

b) To check up whether all girder bridges situated within station limits are provided with foot paths for the convenience of the railway staff.

c) Whether long unballasted girder bridges located between stations are provided with foot paths for the convenience of Engineering staff.

10. Painting, marking HFL and Danger level, providing foundation particulars and bridge name boards : It should be ascertained whether:

a) The date of last painting has been conspicuously painted on the girder and recorded in the Bridge Inspection Register.

b) The Highest Flood Level and the year in which the flood had occurred has been marked and recorded in the Bridge Inspection Register.

c) The danger level has been fixed and marked on the pier/abutment as envisaged in Para 703 and recorded in the Bridge Inspection Register.

d) The direction of the flow has been distinctly marked on the abutment or pier.

e) The plaque showing particulars of foundation have been fixed over every abutment and pier in accordance with instructions in Annexure 11/7.

f) Name boards have been fixed at either approach of important bridge.

g) The Full Supply Level (FSL) has been marked distinctly at all canal crossings in the same way as the HFL for other bridges.

h) The Bridge Number Tablets have been provided on the parapet walls of bridges as per Annexure 2/1

j) The flood gauges have been provided at important bridges for recording flood levels and afflux.

Any increase in HFL during the previous monsoon should be reported to the Divisional Engineer.

11. Flood records at important bridges.

a) It should be ensured that the following flood records are maintained as detailed in para 710 and as specified for each bridge.

i) soundings around piers and abutments during and after high floods'

ii) gauge readings of flood level during monsoon,

iii) observations of afflux and velocity during monsoon'

iv) cross sections of river during and after floods,

v) survey of the river course after monsoon,

vi) cross section of guide banks/protection works and aprons,

vii) annual survey of scour holes.

b) It should be checked whether River and Flood Registers are being maintained for large alluvial and other specified rivers and kept upto date.

12. Precautions against damage by fire :

It should be ensured :

a) That the precautions against damage by fire are adequate.

b) That the sand bins on long girders are kept filled.

13. Equipment of watchman :

To check up:

a) Whether the watchman posted at bridge site is having the necessary equipment as envisaged in Para 705 and whether they are in satisfactory condition.

b) Whether the watchman's knowledge of rules is satisfactory.

14. Road over/under bridges:

a) Road over bridges :

They should be inspected :

i) to ascertain whether the structures are on sound condition,

ii) to check the vertical clearance available is as per schedule of dimensions,

iii) to check the thickness of road way to ensure that the dead load on the bridge does not exceed the maximum permissible,

iv) to ascertain as to whether in electrified areas, safety or protective screens of approved designs (side claddings) are provided for the ROB/FOBs,

v) to examine the condition and adequacy of smoke guards,

vi) to examine the condition of the deck slab for spalling or deterioration of concrete,

vii) to check the condition of any waterproofing or any preservative treatment given to concrete deck,

viii) to check whether at the expansion joints provided, adequate gap is available for the joint to function and for looseness and vertical displacement of one part of the deck relative to the adjoining part,

ix) whether speed breakers have been provided on either side of weak Road Over Bridge and where speed restriction is imposed for vehicular traffic.

b) Road under bridges:

i) to check up whether height gauges are provided,

ii) to check up whether the bottom of girders have been covered by suitable and approved means to prevent droppings, falling from passing trains on road users.

15. Concrete bridges :

a) The condition of bed blocks and bearings, wherever provided should be checked, items of inspection being the same as for steel girders.

b) The camber of prestressed concrete girder should be checked once a year by any reliable method and the same recorded. One method which can be adopted for spans upto 30 metres, is indicated in Annexure 11/14. Alternatively the camber can be recorded by using a levelling instrument or theodolite. The points where the camber is measured should be clearly marked on the underside of the girders so that the readings taken on different years are comparable. While recording camber, temperature should also be recorded and successive readings should be recorded at about the same temperature. Progressive loss of camber is an important indication of deterioration in the condition of bridge.

c) i) The surface of concrete should be checked by a magnifying glass for any cracks.

ii) The location, width and length of crack, type of crack (longitudinal/transverse/horizontal/vertical/diagonal) whether it is active or dormant and its behaviour under live load should be carefully noted and documented. Sketches, preferably photographs should be included. The observation of earlier inspection should be compared for the purpose of determining whether the crack is developing or otherwise. Efforts should be made to determine the probable cause of the cracks.

iii) While inspecting one should look for diagonal cracks in the web of main girders near the support, flexural (vertical) cracks especially in the area of tension steel, cracks near the bearings and longitudinal cracks at supports of slabs or beam near junction of main girder with deck slab and at the diaphragms.

d) While checking the PSC girders for cracks particular attention should be paid to the bearing area, end blocks, anchorage zone, support of main girders, web near girder ends, diaphragms, junction (interface) of diaphragms with web and at junction of main girder with deck slab.

e) It should be checked whether sufficient depth of ballast cushion exists under the track sleepers. The deck slab should be examined after clearing the ballast for any signs of cracking/disintegration and to see whether there is dampness and whether drainage arrangement is functioning.

It should also be checked as to whether water proof layer, if provided is intact.

f) It should be examined whether rust streaks / stain marks are visible parallel to reinforcement; spalling and presence of rust streaks are indicators of corrosion.

g) It should be checked whether there is spalling, caused by separation of the concrete from the reinforcement. In such cases it should be ascertained as to whether the steel is corroded by exposing the reinforcement. The location, depth and area/size of spalling should be noted.

h) It should be examined whether there is scaling, i.e. the gradual and continuing loss of surface mortar and aggregate over an area. Location, area involved and character of scaling should be recorded.

j) It should be checked whether there are signs of disintegration of concrete due to poor workmanship, weathering action, attack by chemicals, etc.

k) Seepage, leakage and efflorescence should be looked for.

**16. Health Monitoring of Very Important Bridges:**

Health monitoring of very important bridge should be done periodically by an independent agency. Health monitoring will include corrosion monitoring, deterioration of material, system damage, retrofitting, etc. The periodicity of health monitoring is recommended as given below.

	Aggressive environment (Extreme, Very severe & Severe)	Other than Aggressive environment (Mild and Moderate)
First Survey	5 <sup>th</sup> year	5 <sup>th</sup> year
Subsequent suveys interval	At 5 years interval	At 10 years interval

**1108. Special Inspection During Monsoon**

1. During floods and/or during spells of heavy rain the Assistant Engineer, Permanent Way Inspector /Inspector of Works should inspect by trolley, foot-plate of the engine or other means the bridges and allied works as frequently as necessary.

2. Where a strong rush of water and heavy afflux occur, they should look for the presence of eddies and back waters which are signs of danger. When these are observed, soundings with the help of echo sounders or probing with the help of log line with a heavy lead weight, rail piece or probing rod must be taken and if scour is detected, boulders or pitching material should be run out and dumped as necessary. As a precautionary measure, traffic may be suspended if long lengths of track with a large number of bridges experience a flood situation and scour cannot be measured, particularly during night time.

**1109. Equipment Required For Inspection of Bridges**

The equipment as suggested in Annexure 11/15 may be arranged by the Railways to enable the various officials carry out the inspection of bridges effectively. In the Annexure suggestions have also been made as to the equipment needed at the various levels. The Chief Engineers may add or delete any item from the list based on the site conditions and experience.





**CHAPTER - XII****PLANT AND MACHINERY OF THE  
ENGINEERING DEPARTMENT****1201. Control of plant and Machinery**

1. All plant and machinery belonging to the Engineering Department should be placed under the charge of a nominated official who will be responsible for their accountal, upkeep and optimum utilisation.

2. For this purpose, plant and machinery may be divided into groups and the controlling officials nominated as under :

	<b>Group</b>	<b>Controlling officials</b>
a)	Engineering plant Reserve	Deputy chief Engineer/Works Manager of the Engineering Workshop.
b)	Plant and machinery other than Engineering plant Reserve used for normal maintenance purpose.	Nominated officer of the Division.
c)	Plant and machinery obtained against sanctioned works of the construction organization	Officer nominated by the Chief Administrative Officer (Construction) /Chief Engineer
d)	Plant and machinery obtained against sanctioned works of open line.	Officer nominated by the Chief Engineer.

Note : Provision of this chapter will not apply to plant and machinery used for mechanical laying and maintenance of track.

**3. Machinery and plant register.**

A machinery and plant register should be maintained by the custodian of the equipment. The machinery and plant register should be maintained in the following proforma:

PLANT AND MACHINERY OF THE ENGINEERING DEPARTMENT

Sl. No.	Description of the Plant	Maker's name	Maker's No, Specification, type, capacity etc.	Year of Purchase	Purchase cost	Machine/ Plant No. allotted	Remarks.
1	2	3	4	5	6	7	8

### 1202. Engineering plant Reserve

1. Purpose: The Engineering plant Reserve is created to “avoid losses from forced sales of serviceable and useful plant left over from special works, which is likely to be required for future special works.” The maximum financial limit for the Engineering plant Reserve is fixed for each railway by the Railway Board.

2. a) The Engineering reserve will include items of plant and machinery of the following description.

i) Light plant.

Blocks pulley, spur geared.

Blocks pulley for rope and wire.

Blowers, Concrete mixers

Compressors of all types, Drills pneumatic and electric

Welding sets, Grinders pneumatic and electric

Hammers-pneumatic-rock drilling and riveting.

Holders on pneumatic, Lorries, Motor

Machines- screw cutting, Motor engines

Pavement breakers-pneumatic, pile hammers (Mc. Kiernan-Terry)

Plant Oxy-acetylene.

ii) Heavy plant

Air receivers

Blocks pulley differential

Boilers of all types

Crab

Cranes steam or diesel upto 5 tonne

Dredgers

Gantries for girder erection

Jacks, screw and hydraulic type,

Jolly boats

Lathes of all description

Machines drilling, grinding, planing, sawing and shaping  
plant boring

pumps and pumping plant of all description

pile driving sets, stone crusher,

sling chains certified, shackles tested and certified, winches and  
Hoists,

iii) Special plant

a) Cranes steam or diesel above 5 tonne, service girders (spans)  
and steel work such as CC crib, trestles etc. for emergencies.

b) Engineering plant reserve should also include

i) Small tools and stores likely to be required in an emergency.

ii) Materials required for maintenance and overhauling of plant  
and tools.

c) The Chief Engineer may include certain items not shown in the  
above lists if found necessary.

3. Instructions regarding custody, receipts, issue and accountal  
of Engineering plant reserve are contained in Chapter XIX of the Indian  
Railway Code for the Stores Department.

### **1203. Plant and Machinery for maintenance**

A scale of plant and machinery for maintenance will be fixed  
for each Engineering Supervisor by the Chief Engineer. On issue to  
the appropriate head of account, their cost is charged off finally. It will  
therefore be necessary for the supervisors to maintain plant & machinery  
register as per para 1201 and submit it after the close of each financial  
year to the Divisional office for check.

**1204. Plant and machinery procured for works against specific sanction/projects**

1. In the case of plant and machinery procured for sanctioned works including track renewals, a yearly balance return should be submitted by the Executive to the Chief Engineer. A record should also be kept in the same form by each Assistant Engineer or supervisor of all plant and machinery in his custody.

2. Proper Accounts of plant and machinery issued for use by the subordinates of the sub-division or temporarily lent to contractors, as well as of those articles lent to local bodies and other under competent authority should be kept in a manuscript register showing:

- i) the person to whom lent
- ii) description of items lent
- iii) date of issue, and
- iv) date of return.

These accounts should be reviewed periodically with a view to ensure that items are returned without unnecessary delay and in good condition. This applies also to plant and machinery sent out for repairs. On completion of works, a review should be made of the available plant and machinery and action taken as indicated in para 1205.

**1205. Transfer of plant and machinery on completion of work**

1. Transfer to other works: If a plant released from a work is in good condition and fit for further use without any overhaul or repairs, it may be transferred directly from one work to another on which it may be required, instead of being returned to the reserve.

2. Transfer of plant to reserve: All useful plant for which there is no immediate demand on the open line or construction should be transferred to the Engineering plant Reserve with the approval of Chief Engineer.

**1206. Plant numbers**

Each plant and machinery in the Engineering reserve, division and construction should be allotted a separate number which should be conspicuously painted on the plant itself.

The plant may be classified according to its category and the numbering done as follows:-

<u>PD-MGS -EPR</u>	<u>PG-MGS-EPR</u>
PN.6	W.3
<u>CE/CN/HWH/EPM</u>	<u>HWH/DN/EPM</u>
M2	S.12

PD-MGS means plant Depot, Mughalsarai

EPR - Engineering plant Reserve

EPM - Engineering plant & Machinery

PN.6 means pneumatic plant No. 6

W means Workshop machinery

M means Miscellaneous Machinery

S means special Plant.

### **1207. Register for Engineering plant reserve**

a) The Depot store keeper or official in charge of plant depot should maintain a combined numerical and priced ledger in the prescribed Form 6, separately for each category of plant.

b) A complete annual return of Engineering plant reserve controlled by the depot showing the balances at the end of March each year should be prepared from the plant register by the incharge, checked by the depot foreman and submitted to the Works Manager/ Dy. Chief Engineer/Engineering Workshop.

c) On the basis of this return, an up-to-date list of the plant available in the Engineering plant reserve will be circulated among the divisions.

### **1208. Valuation of plant**

The value of serviceable plant and machinery rendered surplus on a particular project or railway and transferred to another project or railway or to the Engineering plant reserve should be fixed by the Engineer concerned in consultation with the Accounts Officer concerned after allowing the following charges for depreciation:

i)	Light plant	16% per annum
ii)	Heavy plant	10% “
iii)	Special plant	6% “

Charges for repair and overhaul of plant shall be debited to the work or works on which the plant is used.

Special plant or obtained for some special work which is not likely to be required in the near future but may be required in future for some other special work should be valued as per para 1603 S which is extracted below for ready reference:

“General criterion for valuation - The valuation of material returned from works, particularly of specialised material is difficult problem. Engineers and other parties returning stores and plant are prone to claim ( and provide in their estimates for ) as large a credit as possible for them . But the value of such materials to the railway depends largely on the extent to which they can be made use of. Railway Administrative officers should examine in consultation, if necessary with the Controller of stores or whoever may be thought likely take the material over, the sums provided in estimates as credits for returned material and see that the theoretical values of the material based on further life is ignored and the estimate is based instead of on the possibilities of the material being used again within a reasonable period after return. If there is no likelihood of the material or plant being required again within a reasonable period of return, the credit allowed in the estimate for required value should be kept within the figures likely to be realised for it as obsolete material or as scrap.

Depot and handling charges should be separately assessed. Charges for depreciation on each moving machinery and track machines not included in any of the categories mentioned above will be decided by the Chief Engineer.

### **1209 . Maintenance, storage and repairs to plant**

a) All plant should be maintained in an efficient manner so that these are ready for use. Overhauling and testing of plant at such intervals as considered necessary should be carried out by the official in charge and sufficient spares stocked against specific budgetary provisions.

Particular care should be exercised in the storage and conservation of ropes, chains and lifting tackles. All chains leaving depots should bear a registration number indicating their safe working load. All lifting tackle ropes and chains should be examined by the Inspector in charge every three months.

b) Proper covered accommodation with flooring should be provided for the storage of all plant, preferably close to a siding to facilitate loading and unloading.

c) The allocation of cost of inspection and repairs to plant to bring it to a fully serviceable condition should be determined in accordance with para 1918 S.

#### **1210. Requisitions by Divisional Engineer on plant Depot**

a) The Divisional Engineer should place requisitions on the Depot Foreman for plant required stating clearly the site to which it is to be dispatched, whether special staff is required to work it and the probable period of its use.

b) For operating plant and machinery of special type, at the site of work, staff duly certified by the Depot Foreman should exclusively be employed. When operators are recruited by users of the plant, they should be sent to the plant Depot for examination and certification by the Depot Foreman.

c) While working at site, requisitions for spare parts for plant, irrespective of cost, in the event of such parts needing replacement may be forwarded directly by the Inspector in charge to the Depot Foreman for compliance.

In the event of failures, the officials at site may send pneumatic or small hand tools direct to the plant Depot for exchange along with Issue Notes for the items being returned and requisitions for the items required.

d) In the event of an emergency such as an accident or breach, the Depot Foreman of the Engineering Reserve plant Depot shall supply plant and staff as required or message from the official at site.

**1211. Use of Engineering reserve plant at site of work**

a) Instruction to users - plant issued by a Engineering Reserve plant Depot against a requisition should be accompanied by detailed instructions for maintenance and operation including particulars of consumable stores required and the grade of oil to be used for lubrication.

It shall be the responsibility of the users to arrange for the consumable stores to the required specifications.

b) Minor repairs may be carried out locally where adequate facilities are available in the open market. In the event of a major break down, telegraphic advice should be sent to the Plant Depot and after examination, the plant Depot staff may carry out necessary repairs at site or suggest return of the plant to the workshop for repairs.

c) Inspection by Foreman- The Depot Foreman may inspect any plant operating away from the Plant Depot and bring irregularities in working to the notice of the Engineers concerned. The Depot Foreman may depute any of his staff not below the rank of Chargeman to make an inspection on his behalf. Copies of such inspection reports should be forwarded to the works Manager /Deputy Chief Engineer/ Workshops controlling the machines and the Divisional Engineer using the machine.

**1212. Debits for plant and staff supplied on departmental requisition**

Debit for hire charges on plant and staff against departmental requisitions should include the following:

- a) Plant and Stores-
  - i. Cost of inspection, repairs and replacement of parts required to bring the plant to a fully serviceable condition.
  - ii. Difference between the value of the plant as it stood when the plant was supplied and the value arrived at the time of its return on the basis of para 1208.
  - iii. Freight, transport and handling charges.
  - iv. Actual cost of stores inclusive of freight and handling charges.
- b) Wages of staff :
  - i. Wages inclusive of all allowances
  - ii. T.A. / D.A for staff



Monthly schedules of debits and credits supported by Issue Notes and Advice Notes should be prepared for each Division or Department separately by the Depot Foreman and sent to the Accounts Department within the first week of the following month, a copy being endorsed to the Engineering Accounts Section.

### **1213. Maintenance of Log book for plant**

1. Issue of log books by plant Depot - Such plant as concrete mixers, portable oil engines, steam or diesel road rollers etc. should be issued by the plant Depot with a log book which should accompany the plant whenever it is transferred.

In addition to the log book, a history sheet of each plant shall be maintained in the Depot Foreman's office. Essentials such as major overhaul or complete replacement of a part, should be extracted from the log books and entered in the history sheet of each plant sheets on return of the plant to the depot.

#### 2. Entries in the Log book.

The initial entries in the books will, in the case of all new plant, be made in the office of the Depot Foreman.

- a) On the first page, a description of plant in general terms.
- b) On the second page, a detailed description of the plant including all accessories.
- c) On the third page, a list of spare parts normally available.
- d) On the fourth page, a list of instructions for maintenance, the date or year in which the plant was first brought into use and the desirable period, in hours, between overhauls.
- e) On the fifth page, the normal consumption in litres or kg. per hour of
  - i) fuel oil and
  - ii) lubricating oil

The normal consumption should, in each case be based on the consumption immediately after the last major overhaul of the plant. Space should therefore be left for revised entries, should these become necessary.

f) A few pages of the book will be allotted for recording in detail all repairs and overhauls with particulars of parts renewed and the total cost incurred, each entry being preceded by a record of the dates and the total hours run by the plant at the time of the repair or overhaul, the latter figure being obtained as from sub-para (g)

The details should be neatly entered by the official incharge when the plant is repaired or overhauled in the workshop. If the plant is repaired or overhauled at site of work, the entries should be made by the Inspector in charge of the Plant, based on the report of the staff who attend to the repairs of over haul.

g) The remainder of the book will be used for recording, in the following form the consumption of fuel and lubricating oil, to serve as a ready check on excessive consumption of either.

Name of work . . . . .

Date	Hours run on Date	Fuel oil used on Date	lubricating oil used on Date	Total hours run to to Date	Total oil used to to Date	Consumption of oil in Litres or Kg.per Hour	Remarks by official Incharge
1	2	3	4	5	6	7	8

Columns 1 to 4 should be filled in daily and column 5 to 8 periodically.

The official in charge should bring to the notice of the Depot Foreman and the Divisional Engineer any excessive consumption of fuel or lubricating oil and any defects in the running of the plant.

**1214. Log Book**

For motor trolleys and motor vehicles separate log books in a suitable form should be maintained by the Engineer in charge.

Normal consumption should be shown in terms of kilometres per litre. The Kilometres run should be recorded instead of hours run, the fuel consumption being shown against the kilometreage, the aggregate kilometreage run being indicated after each run.

**1215. Hiring out of engineering plant**

a) Plant that is not likely to be required for current railway works may with the approval of the Chief Engineer, be hired out to other Government Departments, private bodies or Contractors provided that it is used in the interest of public service and handled by competent staff.

b) The terms and conditions of hire of plant and loan of staff, if any, should be covered by an Agreement to be signed by the Railway and the party concerned. A copy of the Agreement should be sent to the Accounts Department who will ensure the recovery of hire and other charges on bill preferred.

c) The form of agreement shown in Annexure 12/1 may be adopted for the purpose. Hire charges referred to in the agreement shall be fixed for each item by the Chief Engineer. The hire charges should be worked out on the basis of the market value of the new plant and (not the book value) to which 12.1/2% supervision charges will be added. The hire charges per annum will be calculated on the following basis or any other basis prevalent in the Railway.

i) Interest on capital cost at the ruling rate of dividend payable by Railways to General Revenue.

ii) Ordinary repairs & maintenance charges at 5 %

iii) Special repairs & maintenance charges at 10 %

iv) Depreciation charges as per para 1208.

v) An additional 10% on the sum of (i) to (iv) above, to meet contingencies.

Hire charges per day would be worked out by dividing Annual hire charges by 250,

d) In the case of breakage or loss of any part of accessory, other than the parts liable to wear or in the event of the loss of the entire plant, the costs of replacement to be respectively borne by the Railway and the Hirer as required under Clauses 8 & 9 of Agreement at Annexure 12/1 may be determined according to para 1931 S which is reproduced below for ready reference.

"Breakage or loss of parts- In the case of breakage or loss of any part or accessory, other than the parts liable to wear out referred to in the schedule attached to the Agreement for Hire of a plant, the cost of replacement shall be shared between the railway and the hiring departments, the railway accepting a fraction of the cost represented by the actual life of the part divided by the assumed life i.e.  $R \times N/L$  and the hirer a fraction of the cost represented by the difference between actual and assumed life divided by the assumed life i.e.  $L - (N \times R/L)$  (vide paragraph 1913). Unless expressly stated before hand in writing, all parts and accessories shall be taken as having the same life as shown for the plant on the railway's books, the assumed life of all machines when not otherwise stated shall be taken as 15 years".

Para 1913 referred here on above is reproduced below:-

"1913. Valuation of plant- The value of the plant sent to the Reserve will be fixed by the Controller of Stores in consultation with the Chief Engineer, after consideration of the original value of the plant, the time which it has been in use and its condition at the time of return, as also the current purchase price of new plant. In all cases of "Special plant" purchased for work a kind that is not frequently undertaken, it should be seen that the value at which such plant is taken into the Engineering Plant Reserve is as low as possible consistent with the possible price plant may fetch in the market. The following formula may be used as a guide in all other cases. The value fixed should be entered in all the copies of the Advice Note (S. 1539) and the several foils disposed of as usual.

Formula :-

The second hand value of a plant is equal to :-

$$R \frac{N}{L} (R-S)$$

Where,

R is the present day price of a new plant; if this is not readily available, R may be estimated taking the original price as a basis.

- N is the age of plant  
L is the average total life of the plant, and  
S is the scrap value ( previously estimated)".

### **1216. Examination of Boilers of the Engineering Department**

Observance of rules:

1. Engineers and Inspectors using steam boilers shall be in possession of a copy of instruction issued by the Mechanical Department and ensure that working, wash outs periodical examination, repairs and overhaul comply with the rules laid down.

2. No boiler should be put into commission unless covered by a certificate of fitness issued by the Boiler Inspector in accordance with the rule nor should it be kept in use beyond the date permitted.

3. Periodical washing out of boilers will be carried out by the Boiler-maker / Chargemen at prescribed intervals.

The Boiler Inspector shall carry out the detailed periodical examination as may be prescribed and arrange for the overhauling required.

4. No person shall be appointed as Boiler attendant unless he has been certified as competent by the Boiler Inspector or by any other official empowered to issue a certificate.

### **1217. Boilers not in use for limited period**

Boilers when not in use for a limited period of not exceeding ten days should be filled with water right upto the top. For this purpose, sufficient fresh water should be added to fill the boiler to the highest possible level and a board with the following inscription attached to it.

“ Boiler filled to highest level. Lower the water level before lighting up”

On the expiry of the ten day limit, the Boiler maker / Chargeman will wash out the boiler and keep it empty , leaving top and bottom inspection joints open for the circulation of air and fix a board with the inscription “boiler empty. “

No boiler which has been laying out of use for six months or over, shall be put into commission until it has been tested at site by hydraulic pressure by the Boiler Inspector and a fresh certificate has been issued.

**1218. Laying of boilers - when a boiler is laid off**

i) All inspection doors and washout plugs will be removed ,the boiler thoroughly washed out, all firebars removed and ashes cleaned out and the inside of the fire box and smoke box thoroughly brushed down. The outside of the boiler shall be painted with red lead or coated with boiled oil.

ii) The Boiler maker / Chargeman shall examine the boiler as soon as possible after it has been laid off, and arrange for requisite repairs; and thereafter he will examine it every 3 months.

**1219. Transfer of boilers**

The Boiler Inspector shall be advised by the Engineering official immediately the transfer of any boiler that takes place and the communication copied to the officers concerned. Likewise the consignee, in acknowledging receipt, should advise the consignor, the Boiler Inspector and the officers concerned.

□□□

---

**CHAPTER - XIII****TRAINING FOR BRIDGE STAFF****1301. Types of Training courses**

Bridge staff need to be trained for their jobs both through theoretical class room training and practical work at site using the tools, equipments and machinery. Training is a continuing process right from the time of recruitment. Following four types of training courses should be organised in the Railway Training Institutes.

- i) Initial courses
- ii) Promotional courses
- iii) Refresher courses
- iv) Special courses

Guidance may be taken from the booklet "Approved Modules for stagewise Training of Group "C" and "D" staff of Civil Engineering Department" issued in August 94 by the Ministry of Railways. The Railways may frame their own course contents if such of those training modules for which the course contents are not available in this booklet. However, broad guidelines for conducting these courses are given in the following paragraphs.

**1302. Initial courses**

1. General : The initial courses are for new entrants to Railway service such as Bridge khalasis (skilled, semi-skilled and unskilled) and Bridge Inspectors and should cover induction aspects as well. The syllabi and the training programme for the initial course should be drawn up by the Chief Engineer, keeping in mind the guide lines given below.

2. Initial course for Bridge Khalasis :

a) This course should be held at the Centralised Training School of the Zonal Railway under the direction of a Bridge Inspector. The course should be of one month duration. The course content should, in addition to field training, include class room lectures when the new entrant is first introduced to the working of the Railway in general and to the Bridge works in particular.

b) The class room lectures should be of twenty days duration and broadly cover the following topics :

Personal safety and safe working methods, particularly in electrified sections, administration of first aid, action in case of emergencies and tools and tackles. It should include introduction to the subject of maintenance and erection of steel girders, PSC girders, and other steel structures in workshops and sheds and platform shelters in a clear and simple manner.

c) Field training for ten days duration should be given due emphasis and include the following :

Maintenance and erection of steel girders which should include rivetting, welding, painting, oiling and greasing of girders, use of temporary girders and stagings with cribs and / or sleepers, maintenance and erection of PSC girders, workshop structures, turn tables, etc. and maintenance of Tools, Plant and Machinery.

### 3. Initial course for H.S. Grade II/Artisans :

This course should also be held at Centralised Training School of the Zonal Railway under the direction of a Bridge Inspector. It should also be of one month duration and have the same course content as for Bridge Khalasis detailed in sub-para 2 above. In addition, the course should include topics relevant to the trade for which the Artisan has been recruited.

### 4. Initial course for Apprentice Bridge Inspectors :

a) This course will form a part of total one year training of the Apprentice Bridge Inspector and will be held at the Zonal Training school. This Course will be of two months duration.

b) The class room lectures should include :

- i) General working of the Railways and organisation of various departments,
- ii) All establishment matters including extant rules and various acts viz. Workmen's Compensation Act, Factories Act, Industrial Disputes Act, Payment of Wages Act, Hours of Employment Regulations, Discipline and Appeal Rules, Labour Relations



- and Permanent Negotiating Machinery, Rules regarding leave, salary and passes, maintenance of service records, muster sheets, witnessing of payment to staff, casual labour, etc.
- iii) Duties of Bridge Staff,
  - iv) Inspection and maintenance of Bridge and steel structures including prestressed concrete girders which should include overhauling, greasing of bearings, method of greasing for all types of girders, rivet testing, method of sample testing, loose rivet diagram, welding techniques, painting, preparation of steel surface for painting, painting schedule of bridge girders and metallising.
  - v) Maintenance of Bridge Inspection Register and other registers,
  - vi) Safety First Rules for protection of staff working on bridges and structures and for ensuring safety of travelling public and railway property,
  - vii) General Rules and Subsidiary Rules which should include basics of signalling, train running including essentials of Absolute Block System,
  - viii) Schedule of maximum and minimum dimensions,
  - ix) Track protection rules,
  - x) Rules for Trolleys and Lorries - working of,
  - xi) Actions during accidents, breaches and emergencies and restoration of through running,
  - xii) Procedure of testing new design of plate and PSC girders and obtaining CRS sanction (Safety Certificate),
  - xiii) Rebuilding of bridges and changing of bed blocks including temporary arrangement,
  - xiv) Inspection and maintenance of turn table,
  - xv) Bridge Rules and General design practices, Specifications for steel - MS, HTS, etc.
  - xvi) Acquaintance with rationalised steel section available in the market alongwith their sectional properties, standard bridge spans with their dimensions and schedule,

- xvii) Erection of Bridge Girders and Calendar Hamilton spans and other steel structures, formulation of launching schemes and field organisations,
- xviii) Anticorruption, Public relations, Civil duties, labour organisation and leadership, Incentive,
- xix) Fabrication of bridge girders and other steel structures such as platform shelters, foot over bridges, tank staging, steel cribs, gantries, overhead cranes, turn tables, Microwave towers etc.
- xx) Office work - Correspondence, recruitment of casual labour, submission of returns, account of stores and bridge materials, imprest, tools, plant and machinery, stock verification, classification and disposal of surplus material and MAS account.

c) Practical Training :

The balance period of ten months will be devoted to field training and shall cover the following :

- i) Various major construction sites, where steel girder/PSC girder erection is going on, and at sites where large scale rivetting is being done,
- ii) Workshops or other sites where fabrication of girders, Microwave towers, workshops, roof structure, platform structures are being carried out including welding and rivetting,
- iii) Sites where bridge painting, oiling and greasing of bearings is being carried out,
- iv) Work sites where regirdering / rebuilding work is being carried out in line block with the use of temporary girders,
- v) Accident sites,
- vi) Workshops to study maintenance of heavy plant and machinery and working of cranes,
- vii) Bridge and structural maintenance work being carried out by Bridge Inspector including Microwave towers.
- viii) Bridge inspector's office for office work.

**1303. Promotional courses**

1. General - The course for promotional training will be necessary in the case of staff promoted from a lower to a higher status by a process of selection and is applicable in the following cases :

- a) promotion from unskilled khalasis to skilled or semi skilled,
- b) promotion from semi skilled/skilled khalasis to Bridge Mistries,
- c) promotion from Bridge Mistries to Bridge Inspector.

2. Promotion from unskilled to semi-skilled/skilled khalasis :

a) The promotional training for the above should be held in a Centralised Training School of the Zonal Railway. The promotional training courses should be undergone by the staff immediately after the promotion, at the first available opportunity. The duration of training will be fifteen days and will have to be under a Bridge Inspector.

b) The course content will include class room lectures as well as practical training / demonstrations in the field. The subjects to be covered shall broadly be the same as for initial course but to a reduced scope (Ref. 1302.2)

3. Promotion to Bridge Mistries :

a) The promotional training will be imparted in the Centralised Training School of the Zonal Railway and the duration of the course will be six weeks. The course shall include class room lectures, alongwith practical working of the various items of work connected with Bridges and Structures.

b) The class room lectures should include the following items :

- i) Establishment - Personnel rules pertaining to salary, leave, Discipline and Appeal Rules, Payment of Wages Act, Muster Roll maintenance, channel of promotion and accounting of stores,
- ii) Bridge and Structure maintenance : Maintenance of steel/PSC/ Composite girders, bearings of all girder bridges, Microwave Towers, workshop and shed structures, other steel structures like platform shelters and flood light towers,
- iii) Girder erection and erection of Microwave towers including workshop structures,
- iv) Rivetting, welding & other maintenance techniques,
- v) Schedule of dimensions,
- vi) Accidents and breaches,

- vii) Instructions contained in G and SR pertaining to protection of track and safety methods particularly in electrified areas, and
- viii) Regirdering of bridges.

c) Practical training - Practical training in the field should receive high priority and should include the following items :

- i) Identification of various parts of a Bridge Structure (particularly steel and concrete) and plant & machinery in use,
- ii) Inspection and maintenance programme of bearings, girders both steel and PSC/RCC,
- iii) Laying of diversions including erection of temporary girders,
- iv) Erection of girders including rivetting, launching and regirdering,
- v) Fabrication of welded and rivetted girders in workshops,
- vi) Erection of Microwave towers and other steel structures,
- vii) Maintenance of tools, plant and machinery.

#### 4. Promotion from Bridge Mistries to Bridge Inspectors / Grade III:

a) General : The object of training the Bridge Mistries for promotion to Bridge Inspectors Grade III is to train them for effective working in a supervisory category. The training should be imparted in the Zonal Training School for a period of six weeks. The course content should include class room lectures, field demonstrations, study tours and screening of instructional films. It should also include an assessment by an examination at the end of the course.

b) The class room lectures shall be on the same subjects as prescribed for initial course for Apprentice Bridge Inspectors but the extent of coverage shall be at a reduced scope, since the serving Bridge Mistries would be having adequate experience in all spheres of practical working. In addition, the lectures shall include procedure for obtaining traffic blocks including messages to be exchanged with the SMs, submission of requisitions for obtaining green notices, routine correspondence with superiors and officials of the other departments, etc.

c) The Instructional tours should include visit to bridge sites where maintenance and regirding works are being done, Engineering workshops, Engineering stores depots, offices of Bridge Inspectors. Special emphasis should also be made on safe working methods.

#### **1304. Refresher courses**

It will be necessary to conduct refresher courses to enable the staff to keep themselves abreast with the latest rules and techniques. Bridge Mistries and Bridge Inspectors should be sent for these courses once in five years. In the refresher courses, all subjects pertaining to the concerned categories shall be dealt with as enumerated under promotional courses but the extent of coverage will be on a limited scale. The duration of the refresher courses shall be three weeks.

#### **1305. Special courses**

In addition to the regular courses mentioned above, special courses for the Bridge Inspectors on any of the following subjects should also be arranged periodically to increase a sense of awareness amongst them on these subjects.

- a) Painting and metallising of girders including oiling and greasing of bearings,
- b) Fabrication and erection of bridge girders including welding and rivetting techniques,
- c) Rehabilitation of bridges,
- d) Inspection of bridges including Numerical Rating technique,
- e) Testing of girders,
- f) PSC Bridges - Construction and maintenance.



## CHAPTER XIV

### BOOKS OF REFERENCES

**1401. Books of references listed in Annexure 14 /1 and other publications from RDSO and IRICEN /Pune including Technical Monographs considered essential should be supplied to the Officers and the Bridge Inspectors of each Division.**

The Chief Engineers and the Divisional Engineers offices should be equipped with adequate number of copies of each publication. The publication should be accounted in the dead stock register. Officials for whose personal use publications are supplied shall be responsible for their custody and handing them over prior to retirement from service.

#### **1402. Circulation of Technical Papers**

The Chief Engineer may arrange to circulate sufficient number of copies of the following publications and such other Journals relating to Bridges and Structures as deemed necessary to the Headquarters circulate them to their Assistant Engineers.

- a) Report of the Bridge Standards Committee,
- b) Journal of Institution of Permanent Way Engineers (India),
- c) Permanent Way Bulletin issued by IRICEN /Pune ,
- d) Technical papers / reports pertaining to Civil Engineering published by the RDSO and Railway Board,
- e) Track and Structures Digest,
- f) Journal of the Indian Institution of Bridge Engineers

□□□

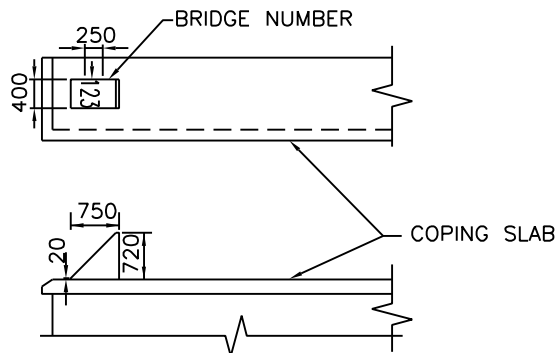
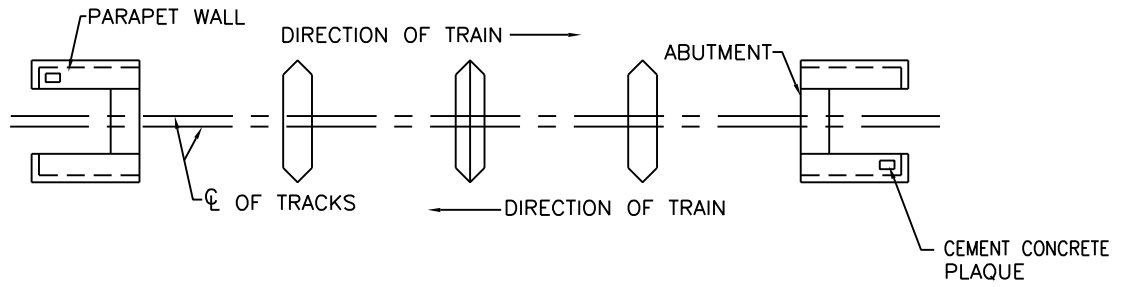
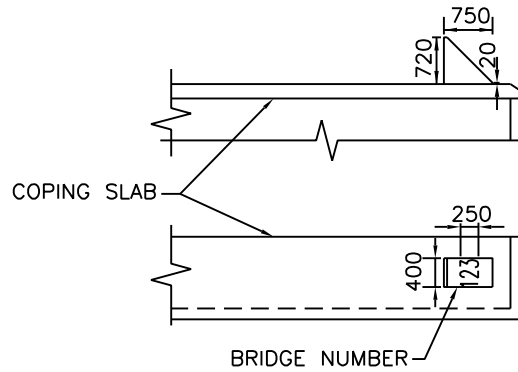
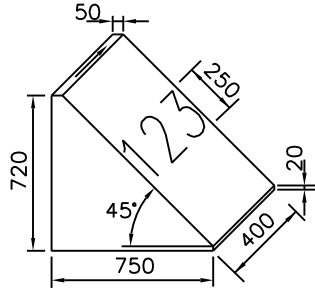

मुंडेर देवार पर पुल संख्या की व्यवस्था  
दर्शाने वाला रेखाचित्र

SKETCH SHOWING PROVISION OF  
BRIDGE NUMBER ON PARAPET WALL

NOTE:-  
ALL DIMENSIONS ARE IN MILLIMETRES ONLY.

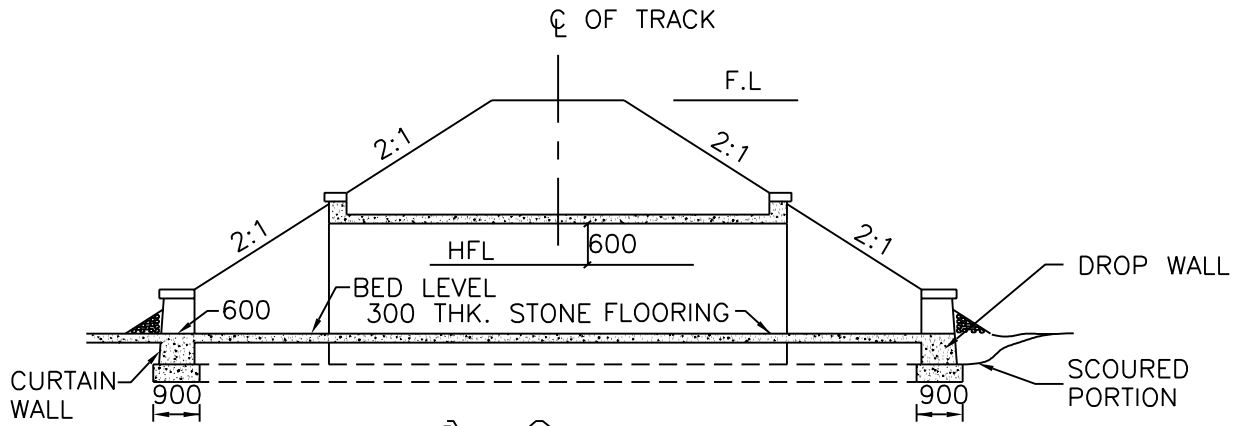

अनुदैर्घ्य खण्ड  
LONGITUDINAL SECTION

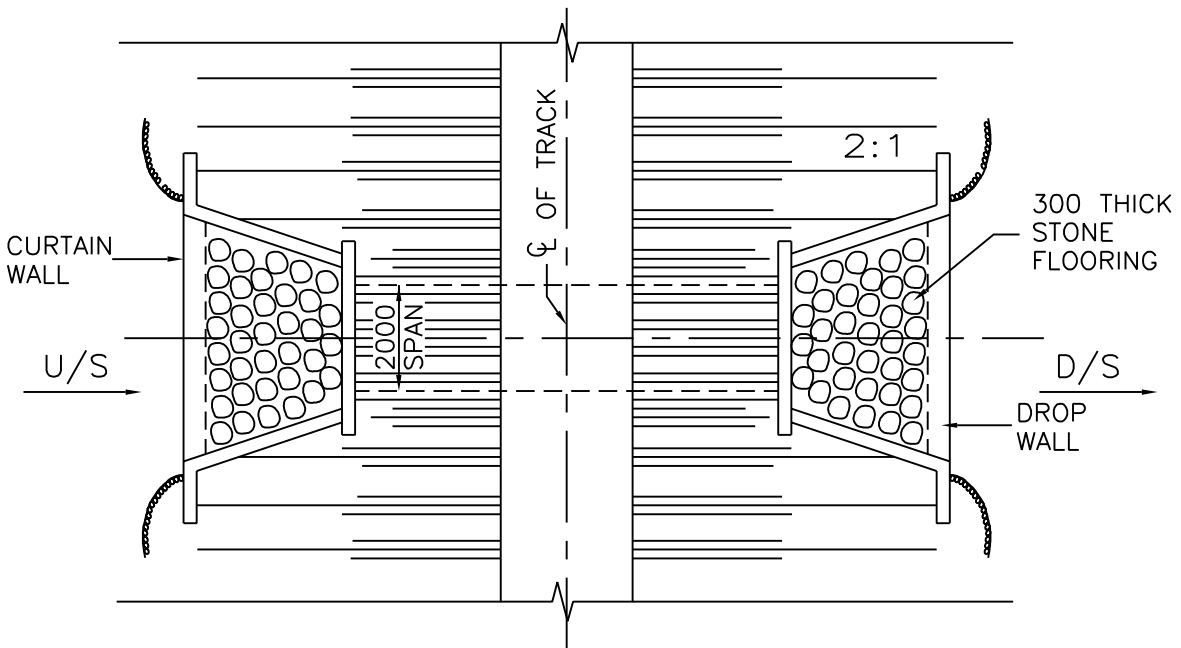

तलविक्षेप  
PLAN

आवरण दीवार, कटावरोक दीवार एवं फर्श  
CURTAIN WALL, DROP WALL AND FLOORING

NOTE:-

ALL DIMENSIONS ARE IN MILLIMETRES ONLY.



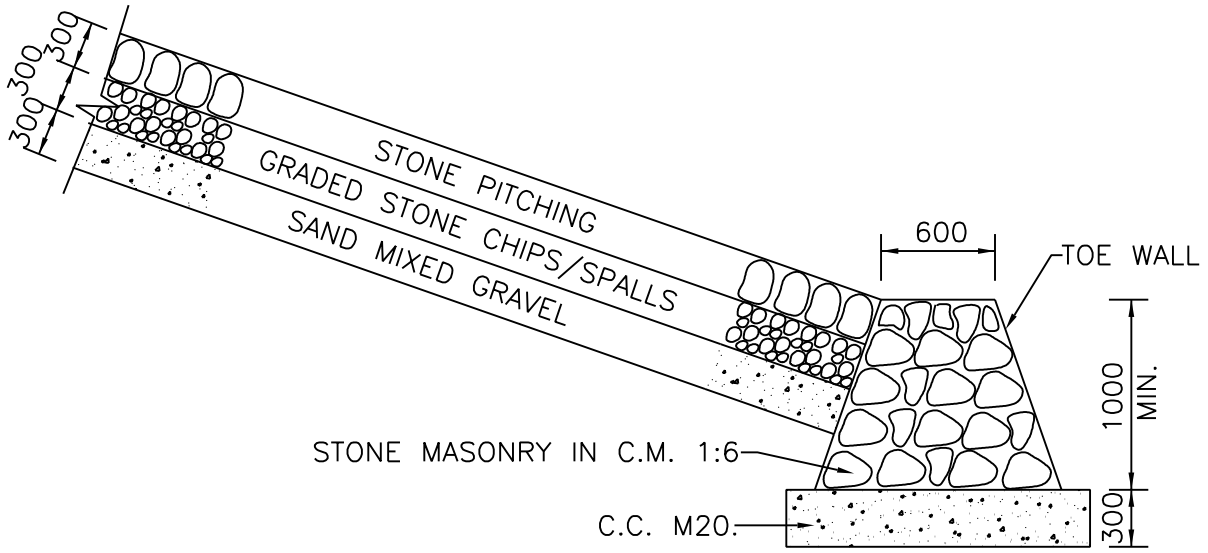

पदार्ग द्वार और कुटाई  
TOE WALL AND PITCHING

NOTE: ALL DIMENSIONS ARE IN MILLIMETRES

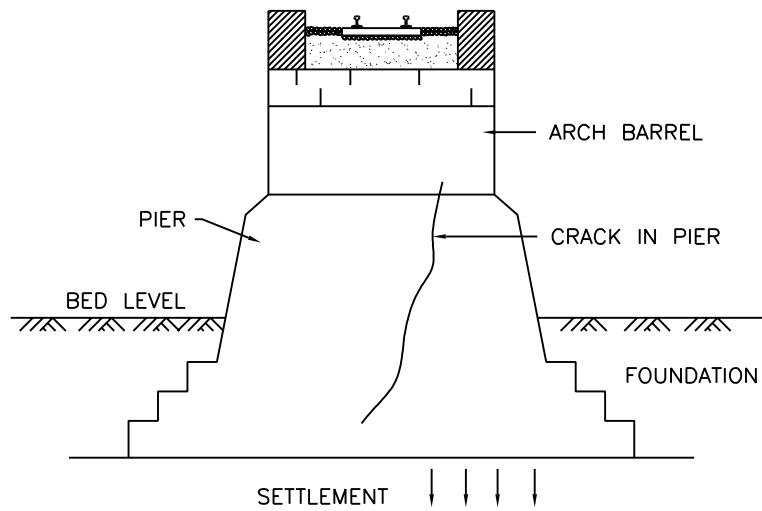

(क) पाये और पीलपार में आर्डि दरारों का बैरल डाट तक बढ़ना

(a) CRACKS IN PIER AND ABUTMENTS  
EXTENDING TO ARCH BARREL

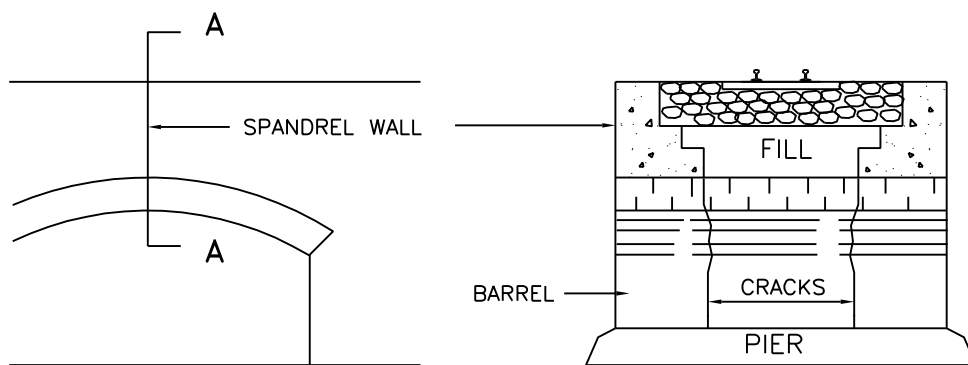

SECTION ON A-A

(ख) त्रिकोणिका दीवार के अंदर अनुदैर्घ्य दरारें

(b) LONGITUDINAL CRACKS UNDER SPANDREL WALL

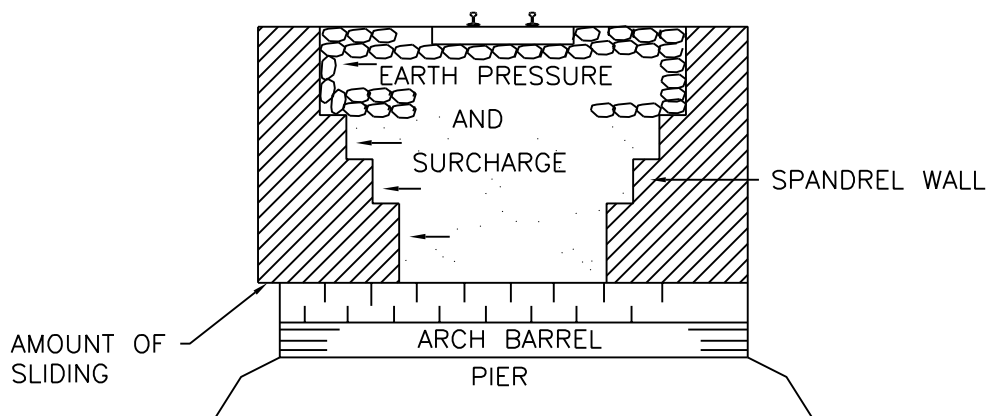

(ग) त्रिकोणिका दीवार का आगे सरकना

(c) SLIDING FORWARD OF SPANDREL WALL

CRACKS ON ACCOUNT OF  
EXCESSIVE RIB SHORTENING  
AND DISTORTION OF ARCH  
RING

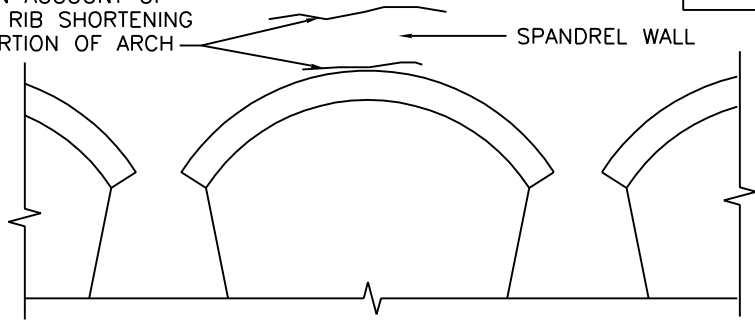

(क) डाट के छल्ले के कमजोर होने के कारण  
त्रिकोणिका दीवार में दरारें

(a) CRACKS IN SPANDREL WALL DUE TO WEAKNESS IN ARCH RING

CRACK ORIGINATING HERE

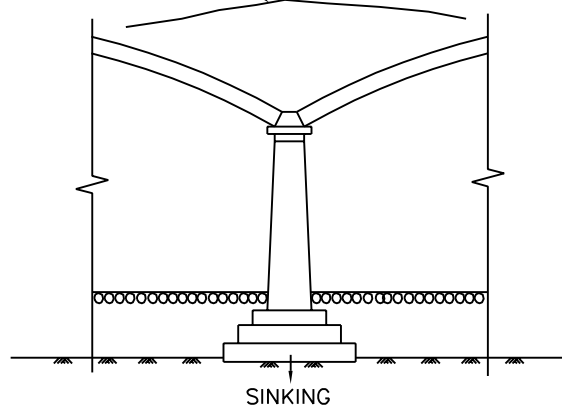

(ख) पार के धंसने के कारण  
त्रिकोणिका दीवार में दरारें

(b) CRACKS IN SPANDREL WALL DUE TO SINKING OF PIER

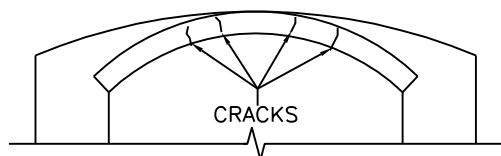

ELEVATION OF ARCH

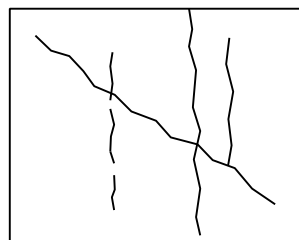

PLAN OF ARCH SOFFIT  
(As seen from below)

(ग) डाट के छल्ले की भीतरी दीवार पर  
अनुप्रस्थ और विकर्ण दरारें

(c) TRANSVERSE AND DIAGONAL CRACKS AT THE INTRADOS OF ARCH BARREL

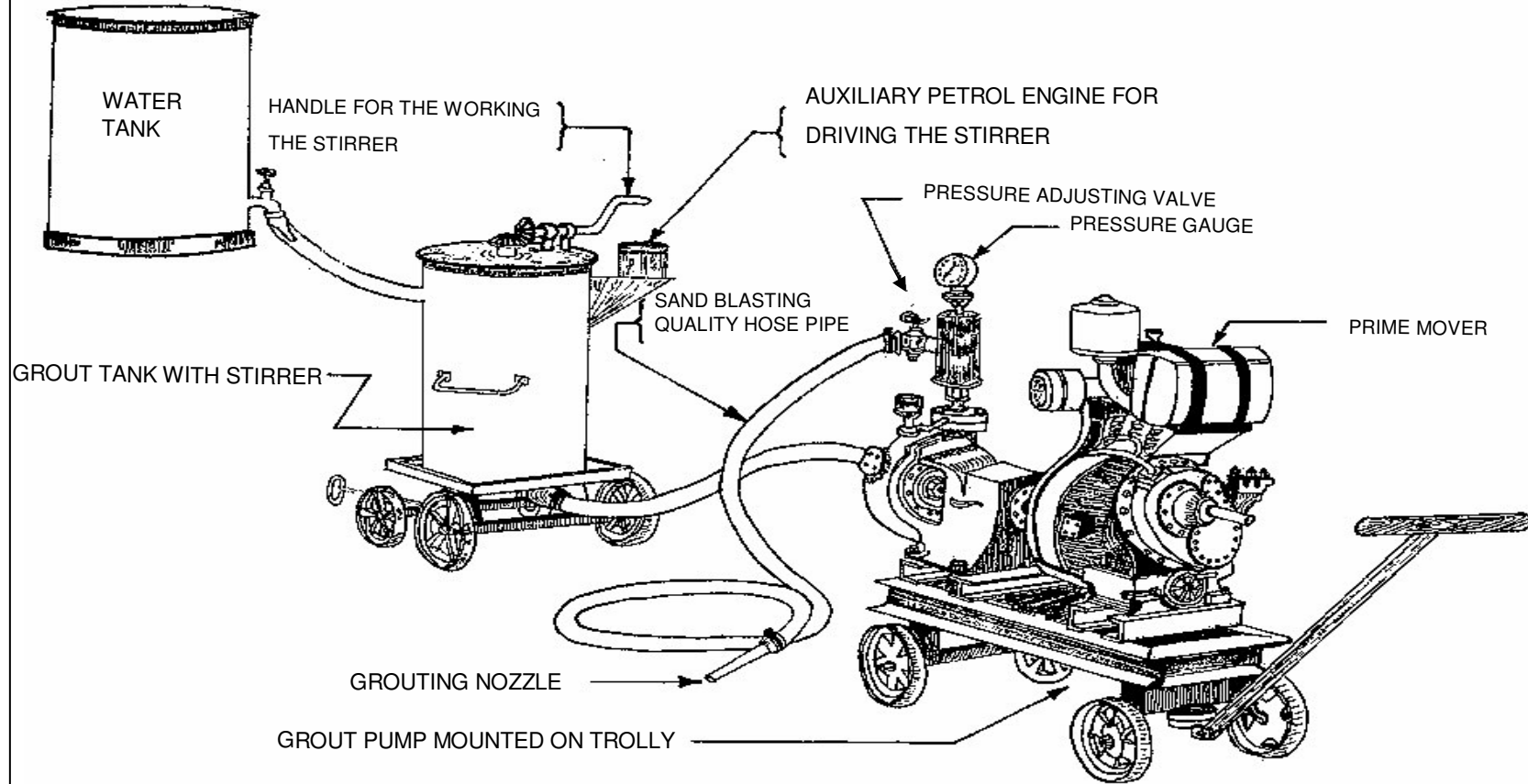

अभिपूरण (ग्राउटिंग) दाब मशीन के ब्यौरे  
**DETAIL OF PRESSURE GROUTING MACHINE**

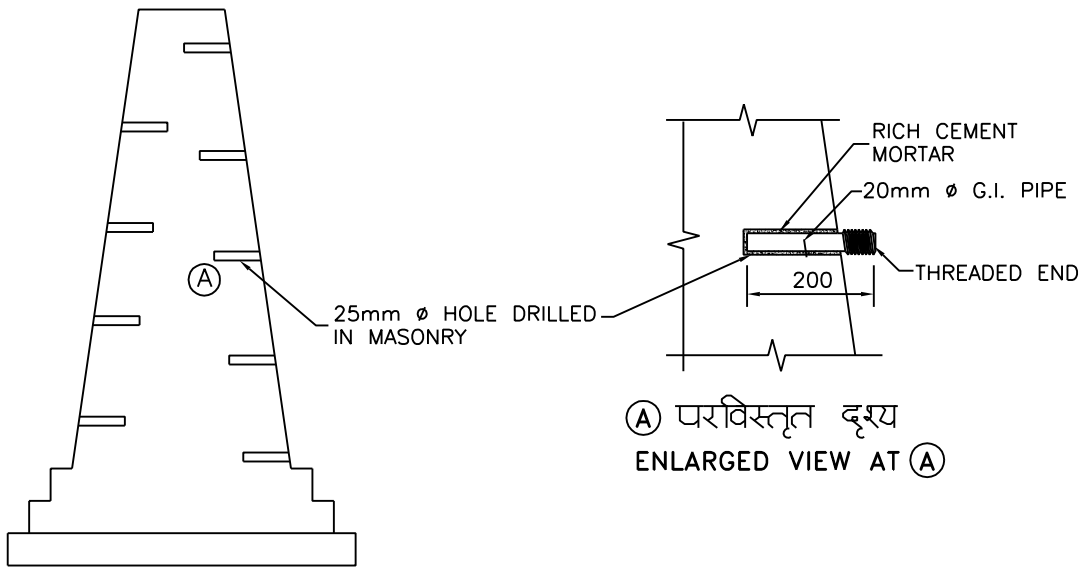
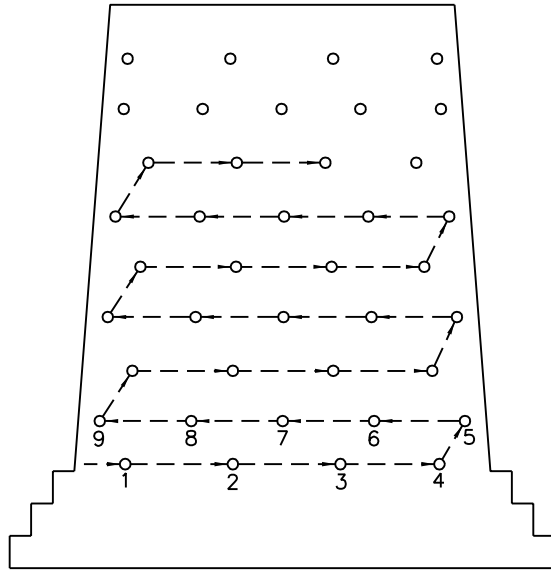

सीमेंट दाब ग्राउटिंग  
CEMENT PRESSURE GROUTING

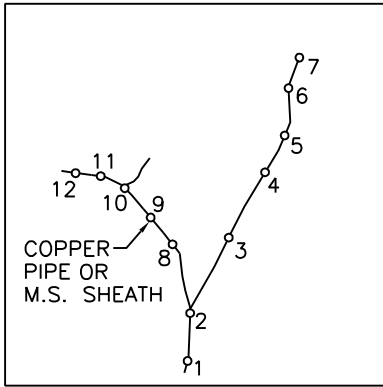

उद्विज्ञेप  
ELEVATION

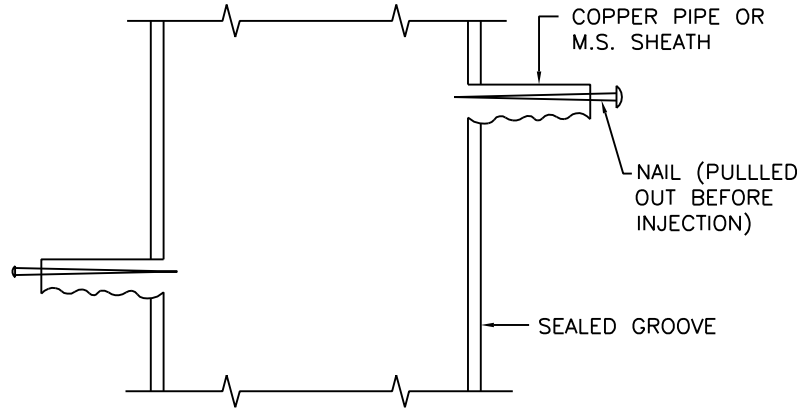

अनुप्रस्थ काट  
CROSS SECTION

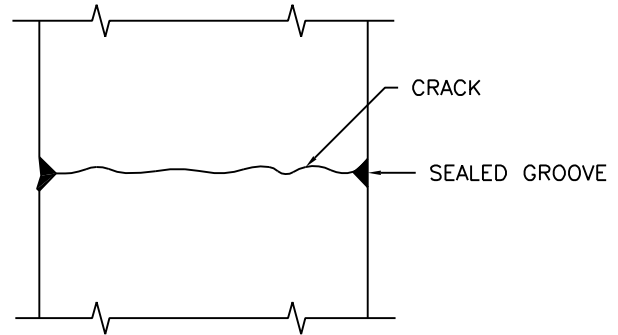
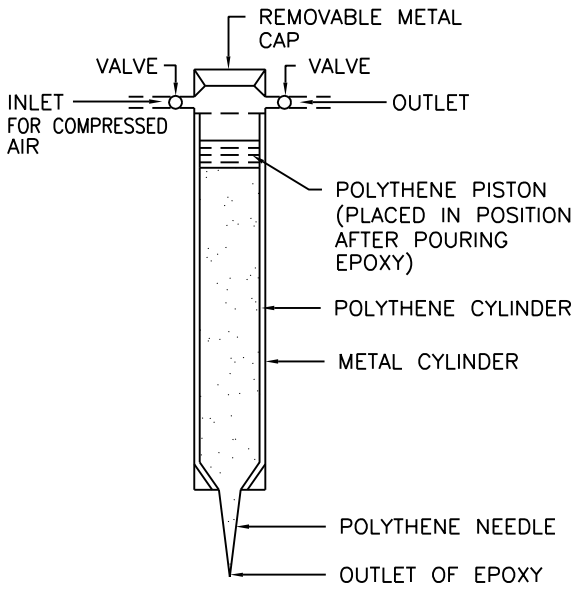

कटीय तलविज्ञेप  
SECTIONAL PLAN

एपोक्सी ग्राउटिंग  
EPOXY GROUTING

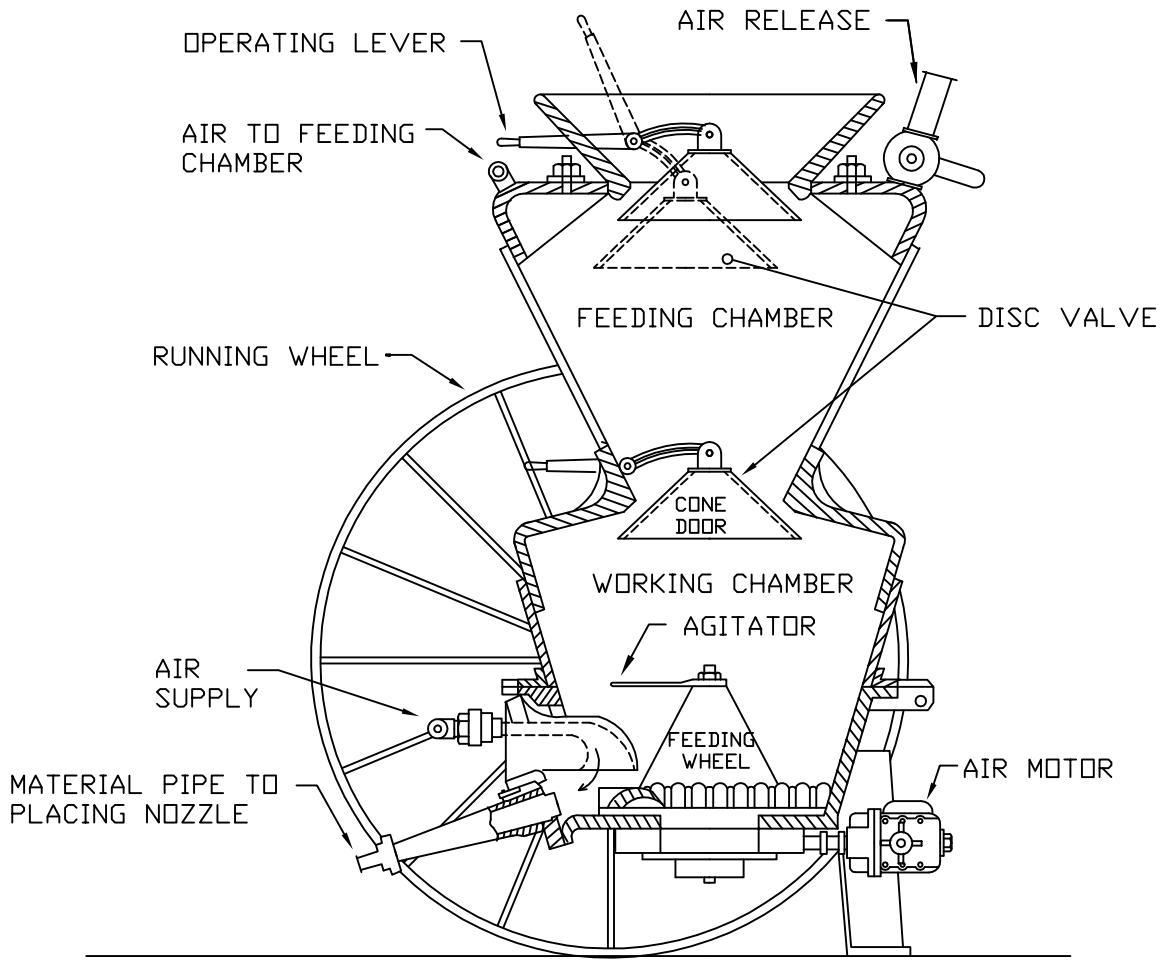

सामान्य व्यवस्था  
 GENERAL ARRANGEMENT

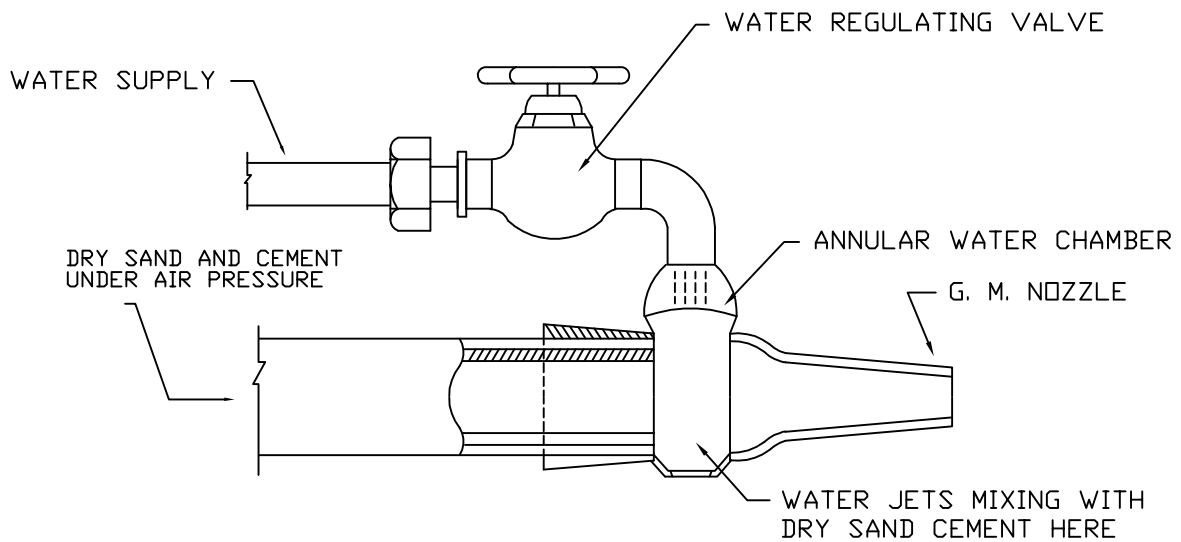

नोजल लगाने के ब्यौरे  
 DETAILS OF PLACING NOZZLE

गनाइटीकरण मशीन  
**GUNITING MACHINE**

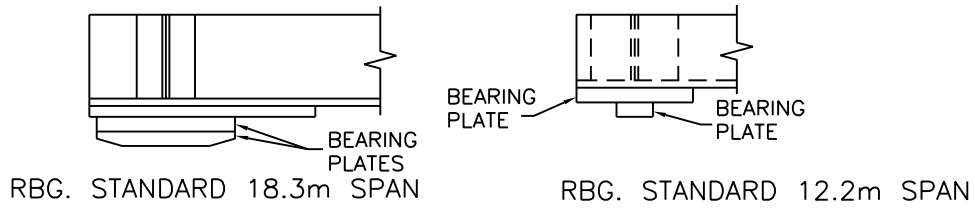

उद्विज्ञेप  
ELEVATION

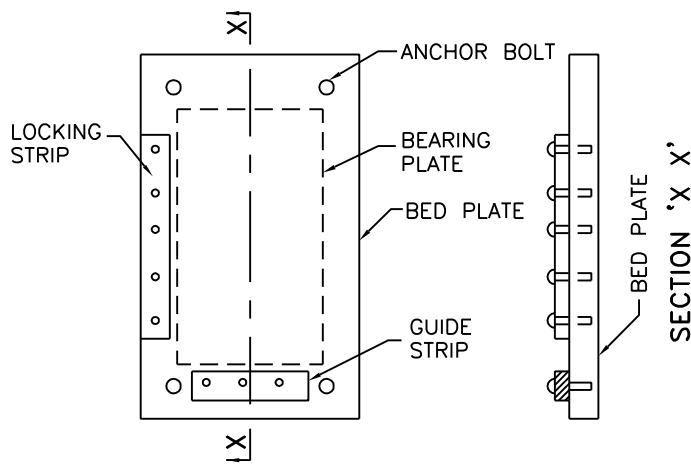

तलविज्ञेप  
PLAN

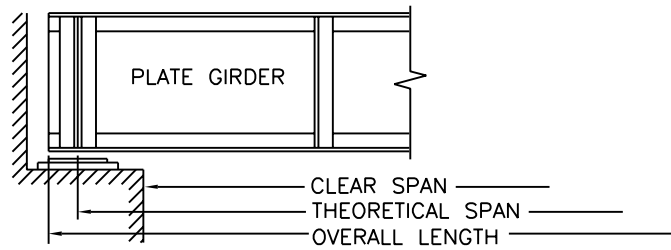

सामान्य व्यवस्था  
GENERAL ARRANGEMENTS

सर्पी केन्द्रिकृत बेअरिंग  
SLIDING CENTRALISED BEARINGS



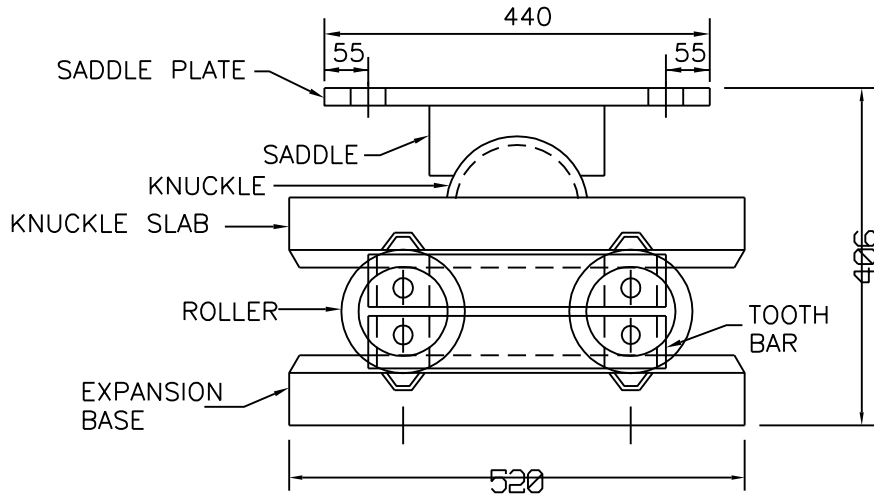

प्रसार बेयरिंग  
EXPANSION BEARING

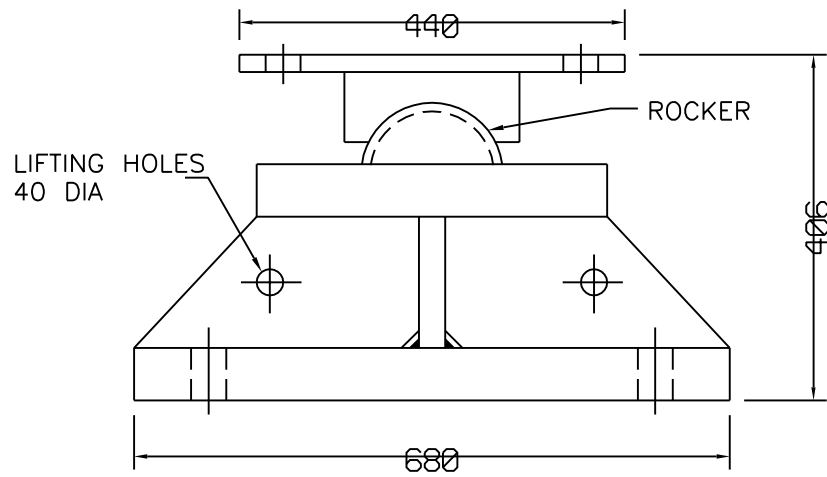

स्थिर बेयरिंग  
FIXED BEARING

रोलर और रॉकर बेयरिंग  
ROLLER AND ROCKER BEARING

NOTE:-  
ALL DIMENSIONS ARE IN MILLIMETRES ONLY.

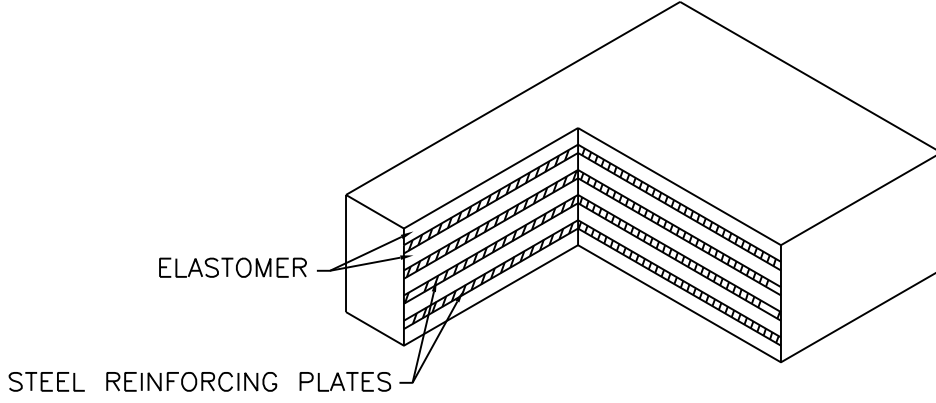

इलास्टोमेरिक लैमिनेटेड बेयरिंग  
ELASTOMERIC LAMINATED BEARING

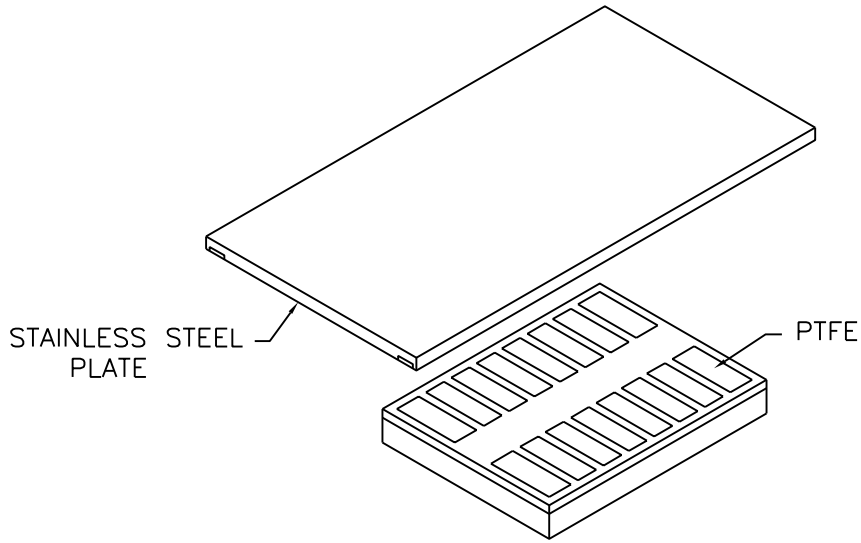

पी. टी. एफ. ई. बेयरिंग  
PTFE BEARING

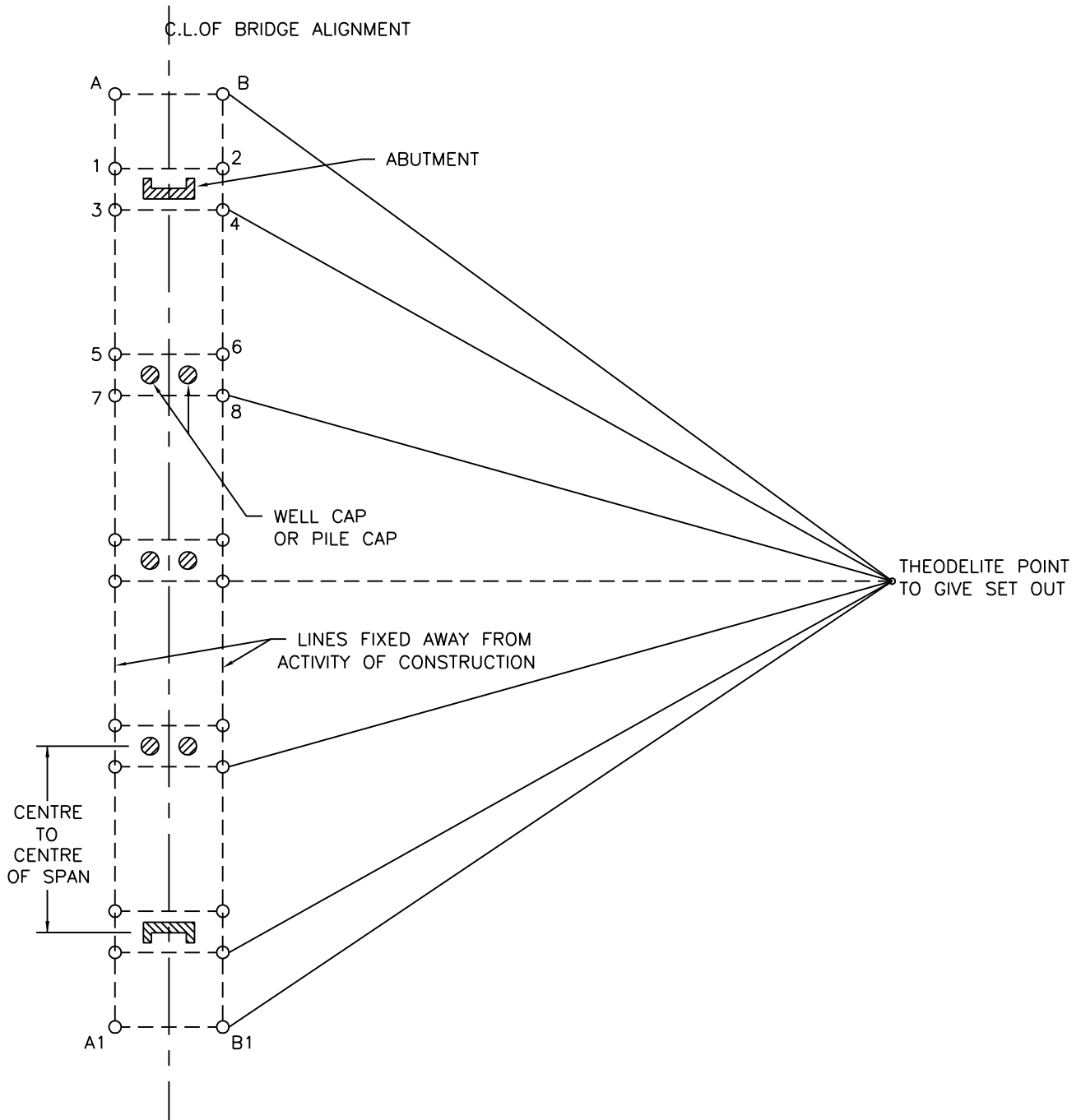

1. 1,2,3,4 ARE PEGS EMBEDDED IN CONCRETE FOR ABUTMENT No.1 AND 5,6,7,8 ARE FOR PIER No.1.
2. AA1, BB1 ARE CORRECTLY SETOUT WITH THEODOLITE AT A DISTANCE AWAY FROM CL AND SHOULD NOT BE DISTURBED DURING CONSTRUCTION.

आधार रेखा के बिना बहुल स्पैन पुल के  
स्थान निर्धारण की पद्धति  
METHOD OF SETTING OUT A MULTIPLE SPAN  
BRIDGE WITHOUT A BASE LINE.

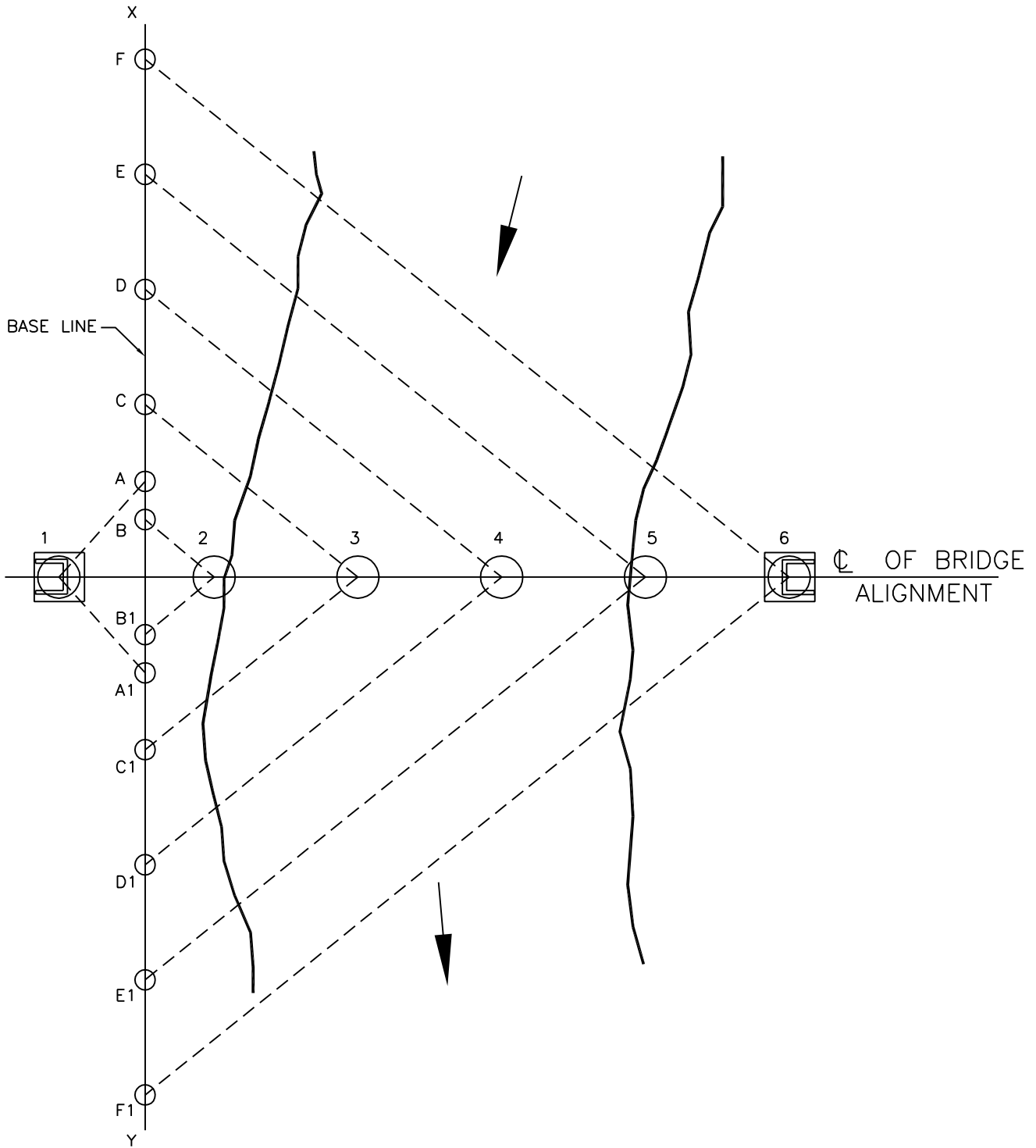

1. B,A,C,D,E,F AND B1,A1,C1,D1,E1,F1 ARE STATIONS ON UP STREAM AND DOWN STREAM SIDE ON THE BASE LINE X-Y.
2. 1 AND 6 ARE CENTRE POINTS OF ABUTMENTS AND 2,3,4 AND 5 OF PIERS.

आधार रेखा की सहायता से बहुल स्पैन पुल के  
लिए पायों और पोल पायों का स्थान निर्धारण

SETTING OUT FOR PIERS AND ABUTMENTS FOR A MULTIPLE SPAN  
BRIDGE WITH THE HELP OF A BASE LINE

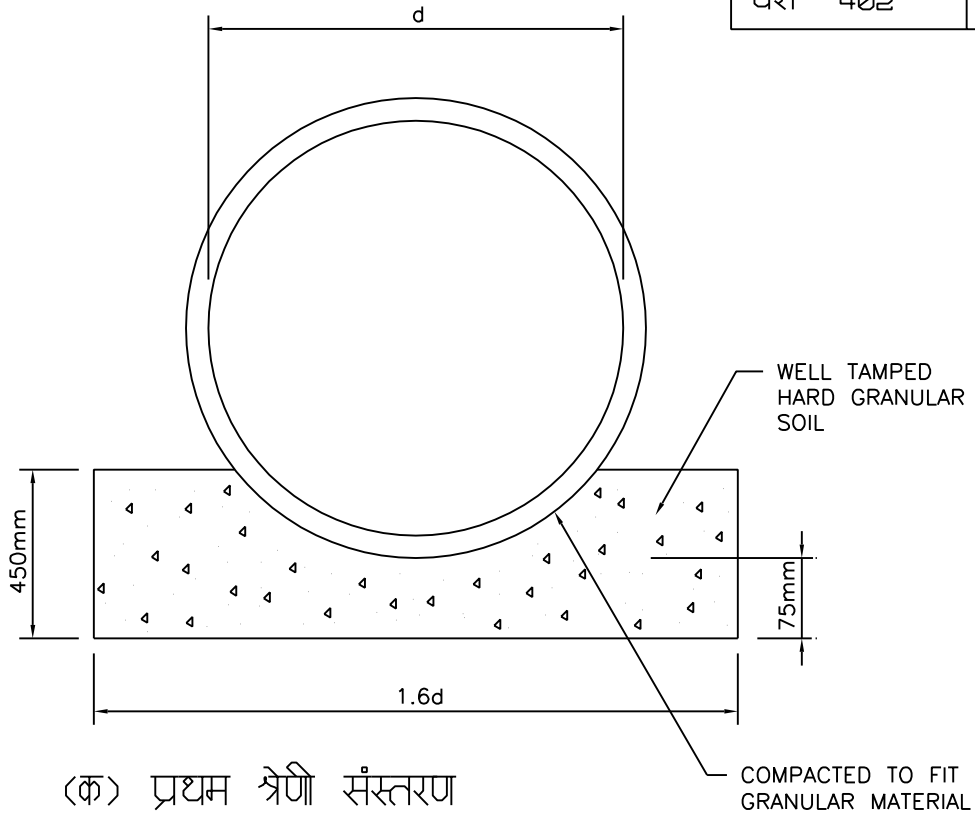

(क) प्रथम श्रेणी संस्तरण  
(a) FIRST CLASS BEDDING

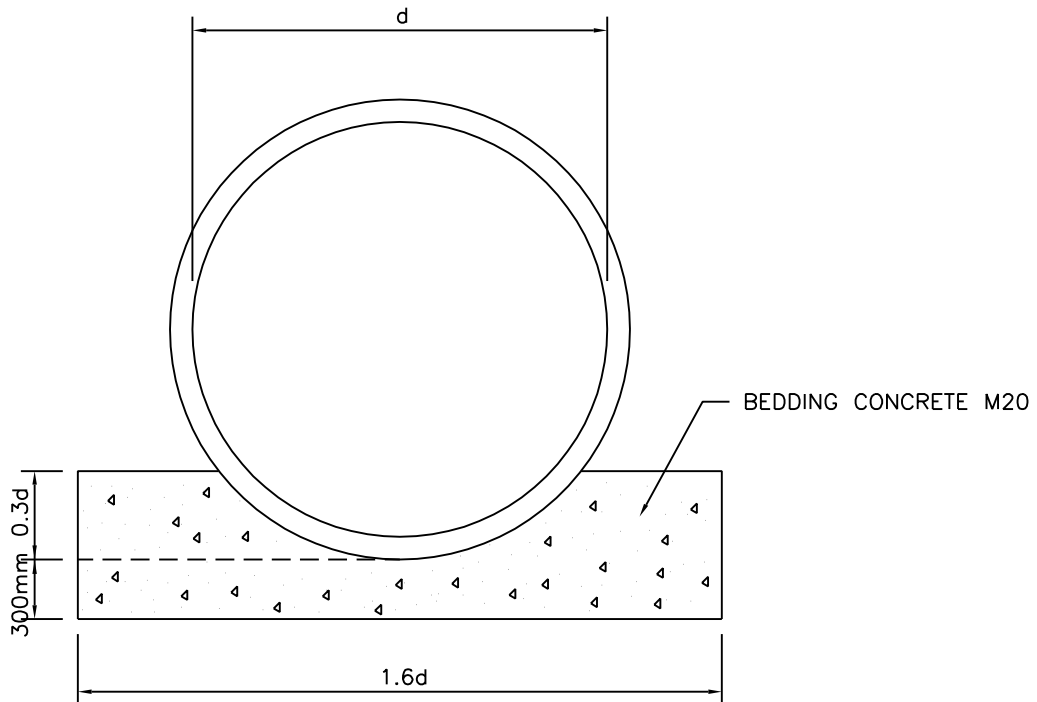

(ख) कंक्रीट ढाँचे का संस्तरण  
(b) CONCRETE CRADLE BEDDING

पाइप पुलिया बनाने के लिए व्यवस्था  
ARRANGEMENTS FOR FOUNDING PIPE CULVERT

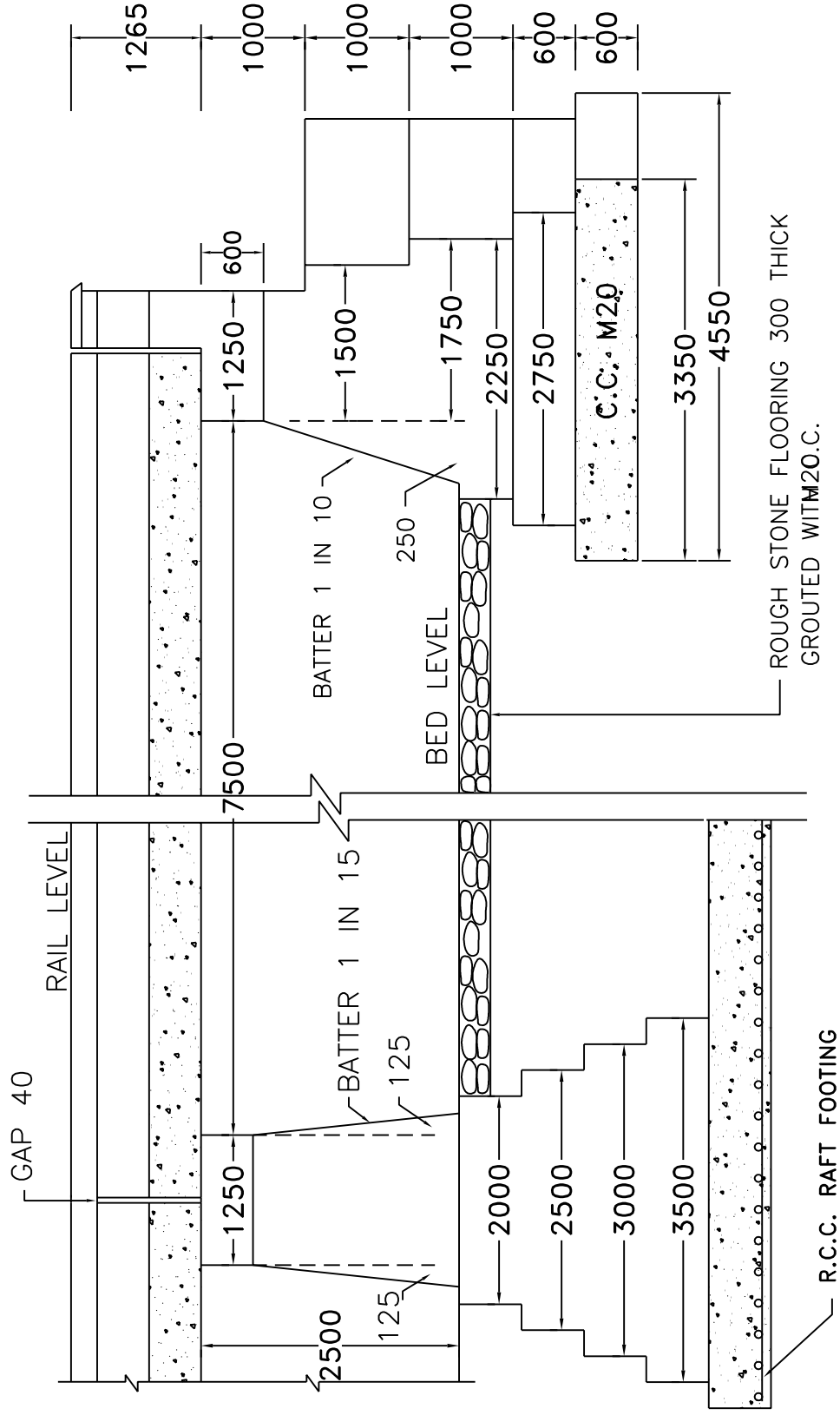

खुली और रैप्ट नीचों सहित पोलपायों और पायों की विशिष्ट काट  
TYPICAL SECTION OF ABUTMENT & PIER WITH OPEN & RAFT FOUNDATIONS

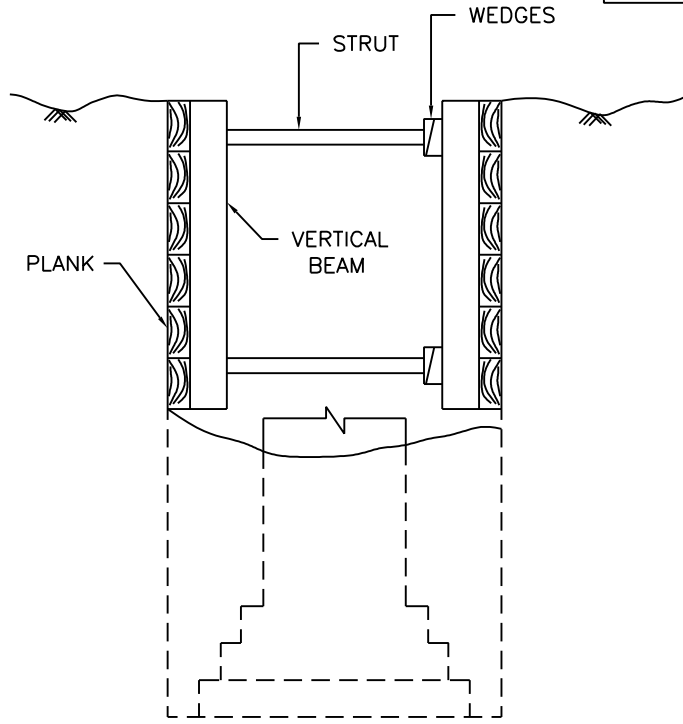

विशिष्ट टेकबंदी की व्यवस्था

ARRANGEMENT OF TYPICAL SHORING

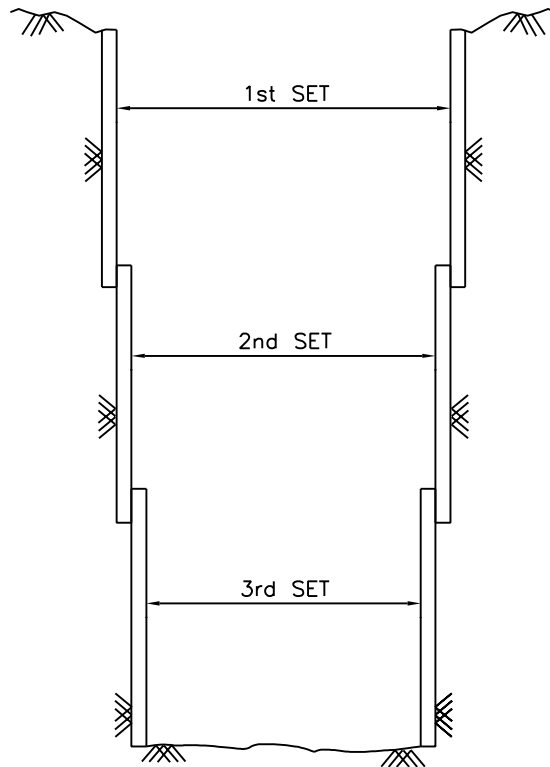

अधिक गहराई के लिए टेकबंदी की व्यवस्था

ARRANGEMENT OF SHORING FOR  
LARGER DEPTH

टेकबंदी सहित पाये की नींव के लिए खुदाई  
EXCAVATION FOR PIER FOUNDATION WITH SHORING

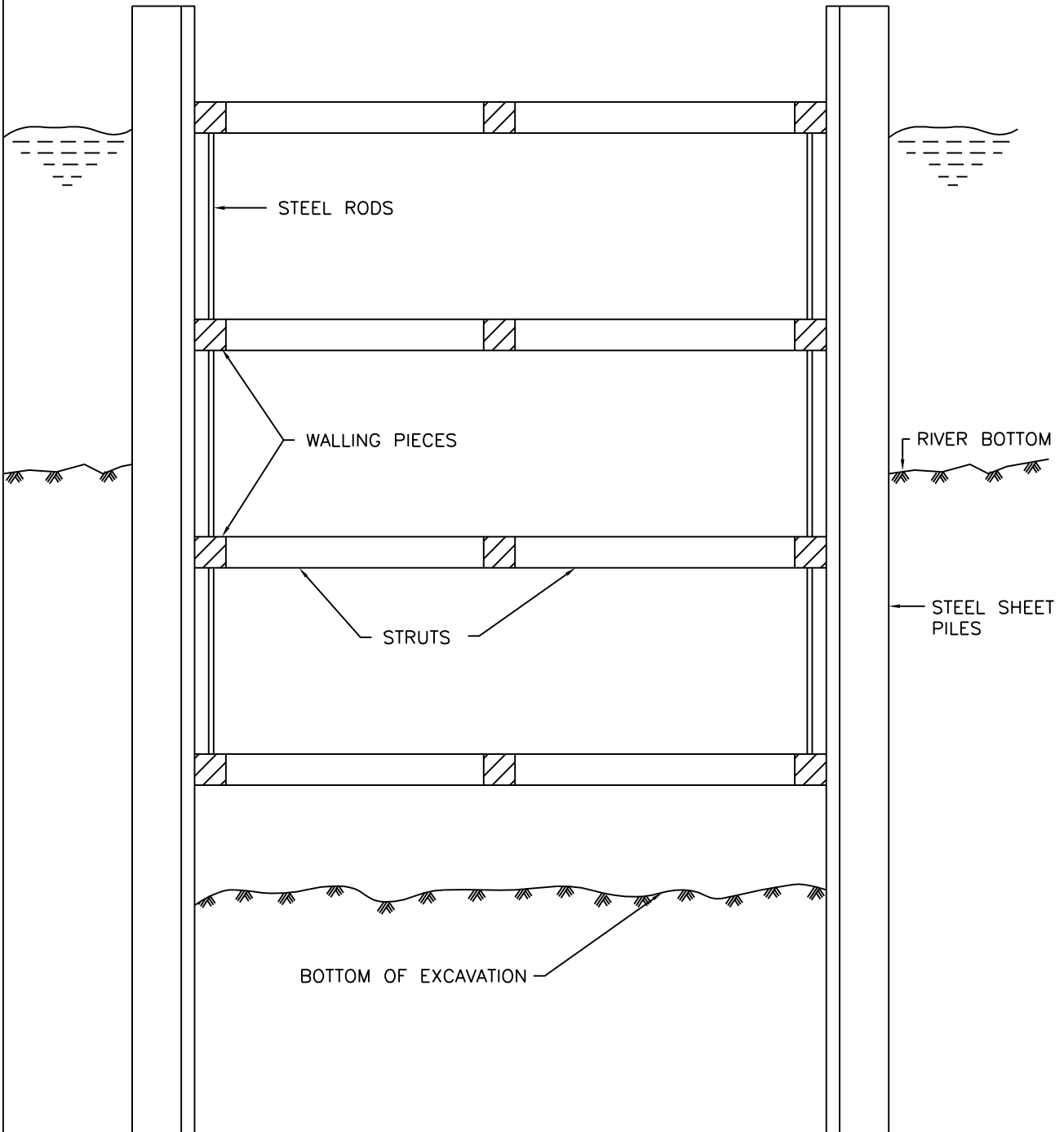

इकहरी दीवार का चादरी पाइल वाला कॉफर बांध

SINGLE WALL SHEET PILE COFFERDAM



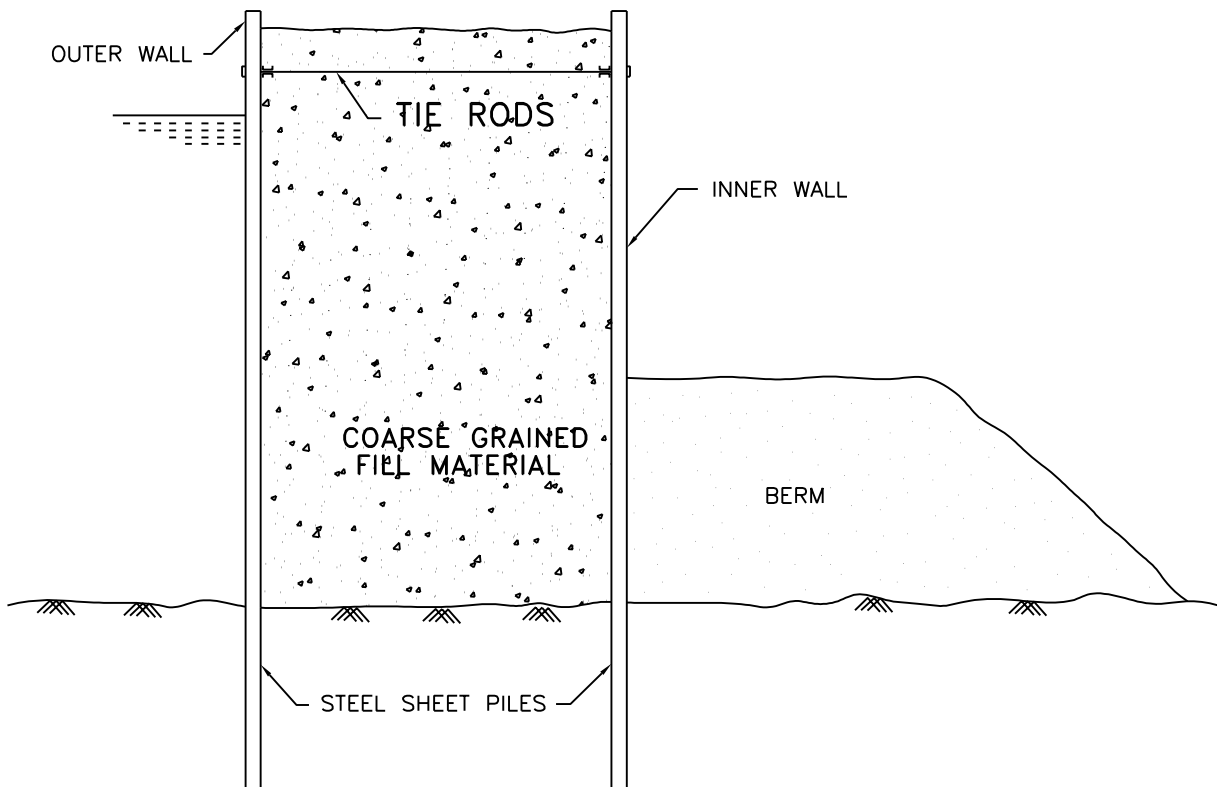

A-A पर काट  
SECTION ON A-A

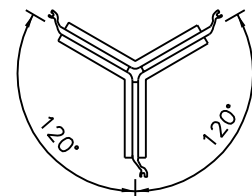
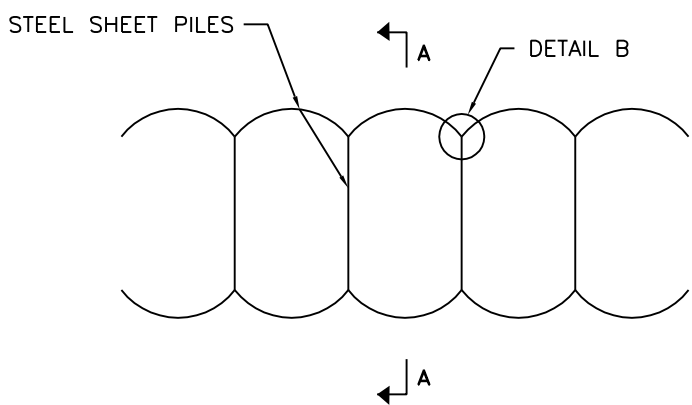

DETAIL AT 'B'

दोहरी चादर की पाइल वाला कॉफर बांध

DOUBLE SHEET PILE COFFERDAM

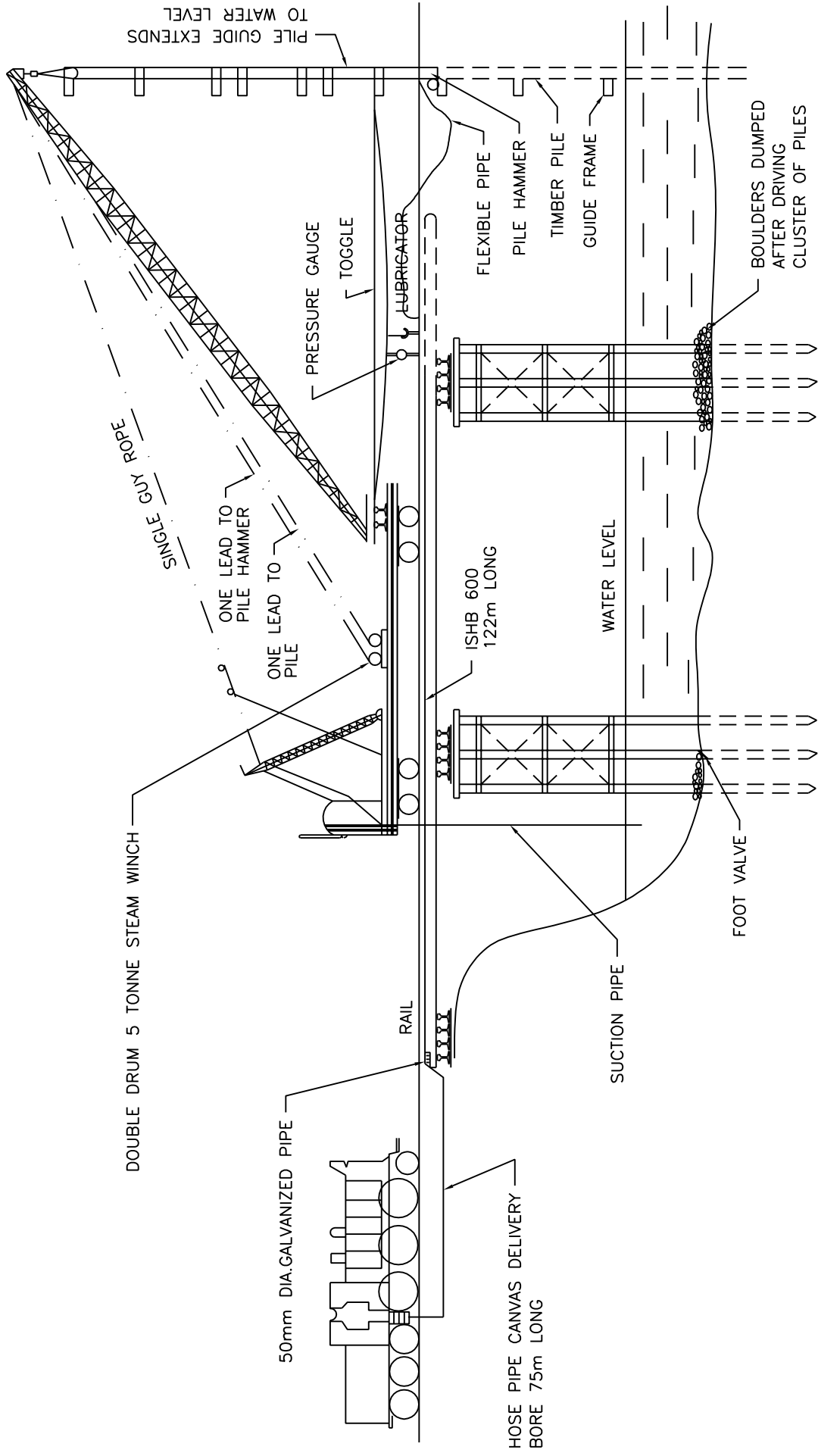

लकड़ी के पाइल वाला अस्थायी पुल  
TEMPORARY WOODEN PILE BRIDGE

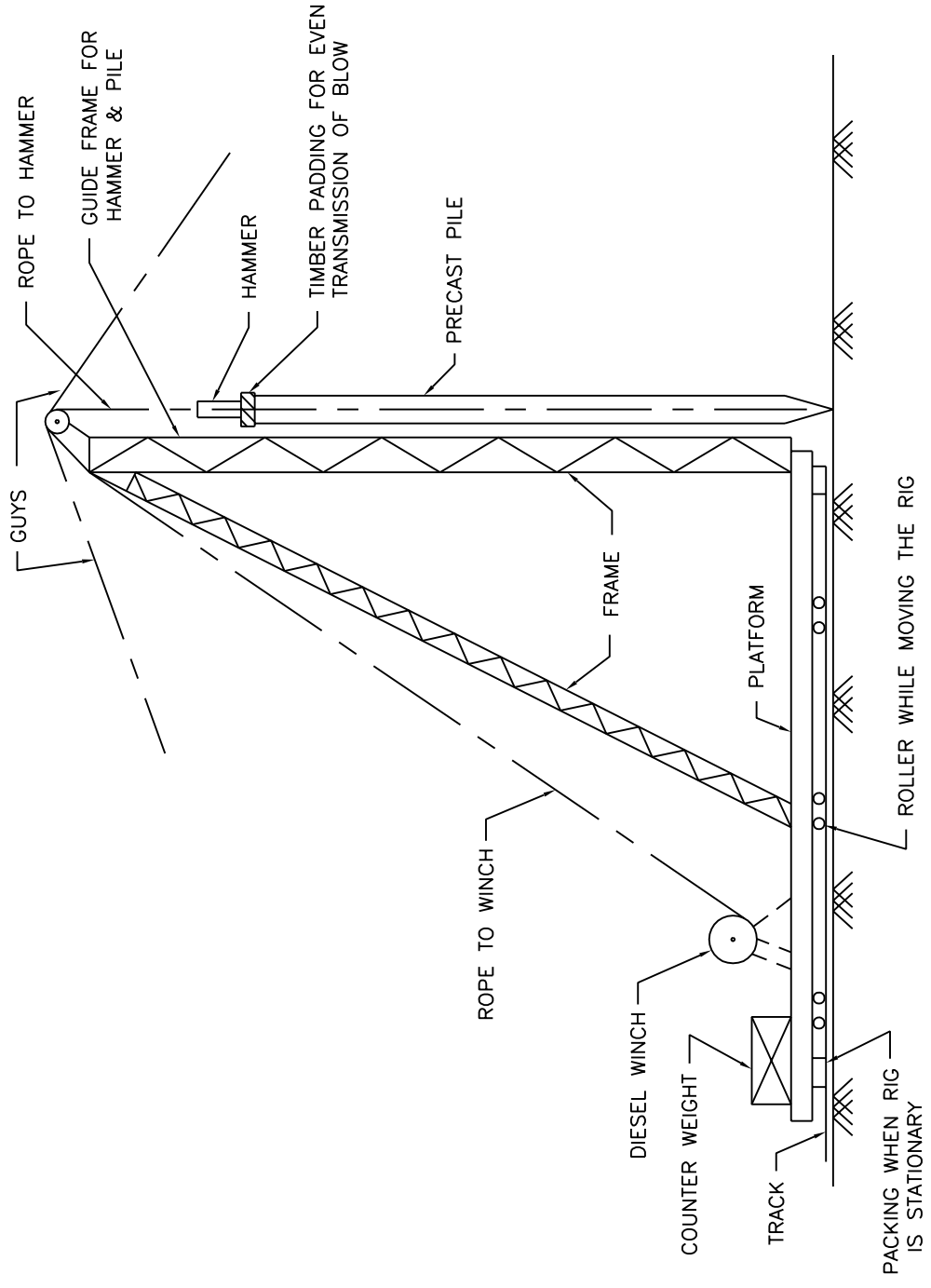

पूरे दृष्टा पाइलों को ठोकने के लिए प्रयुक्त रिग  
RIG USED FOR DRIVING PRE-CAST PILES

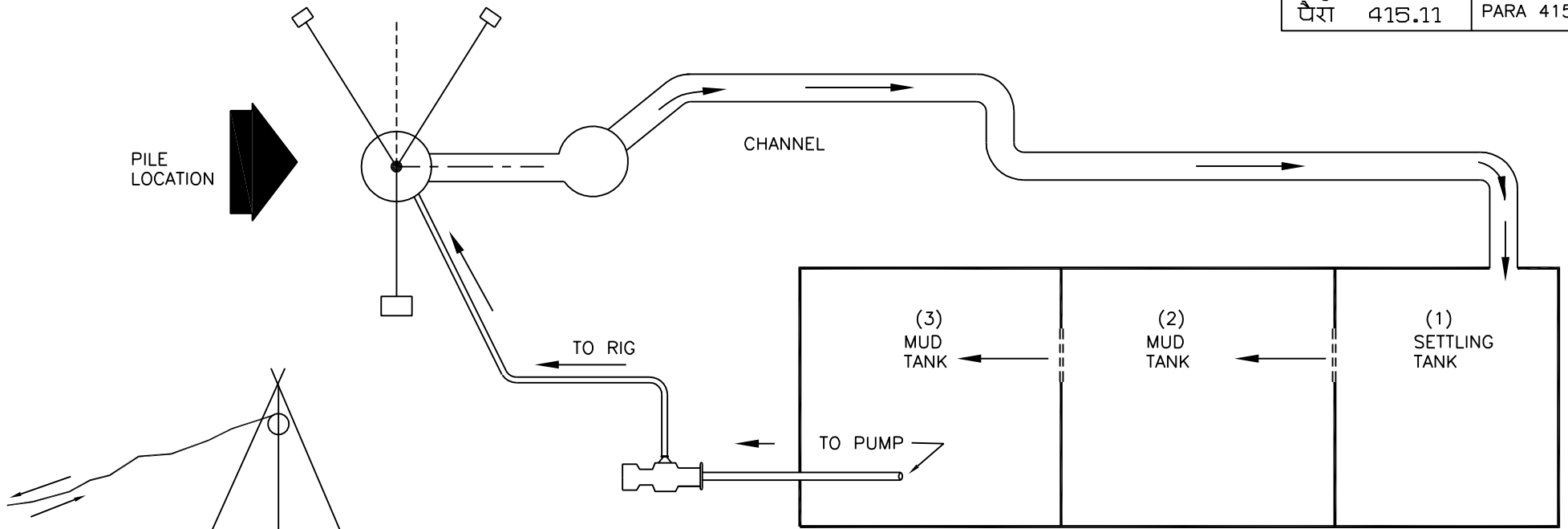

PLAN

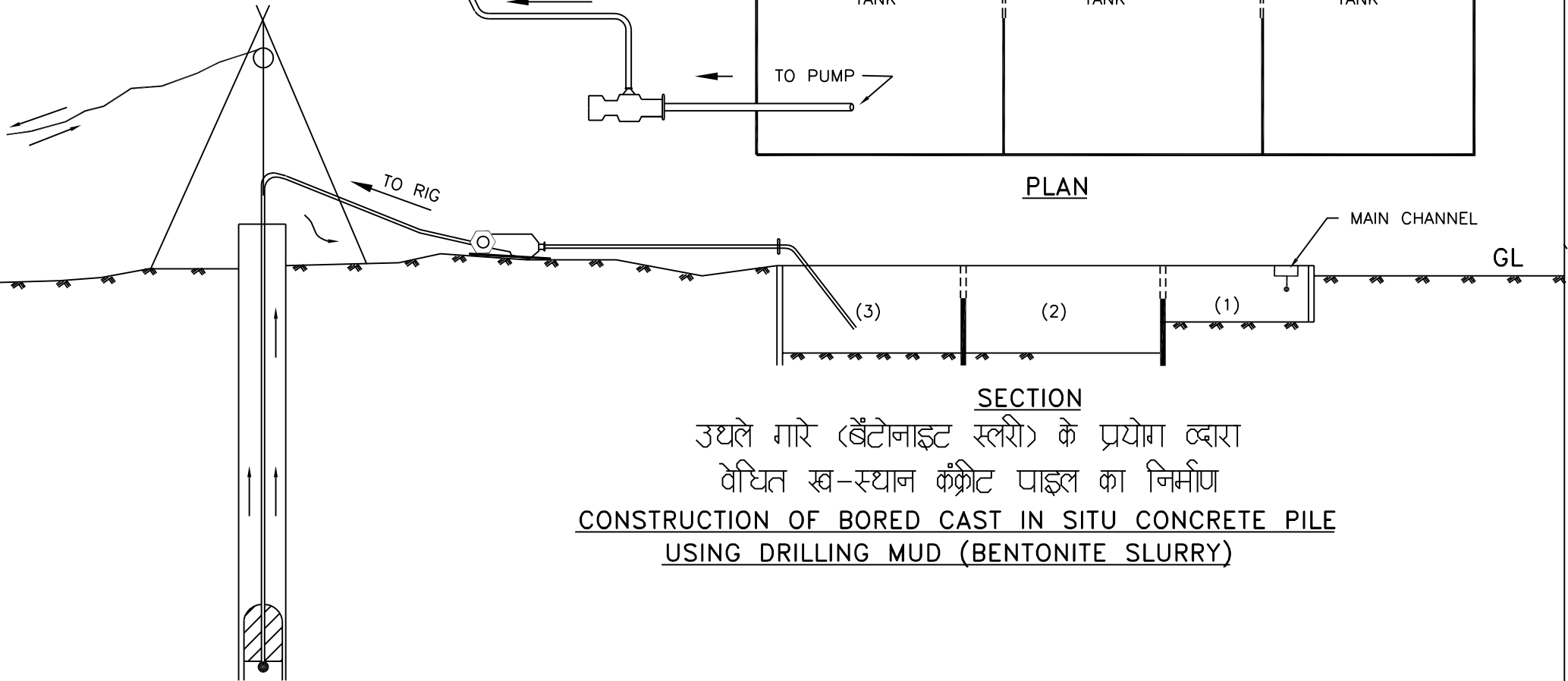

SECTION

उधले गारे (बैंटोनाइट स्लरी) के प्रयोग द्वारा  
 वेधित ख-स्थान कंक्रीट पाइल का निर्माण  
CONSTRUCTION OF BORED CAST IN SITU CONCRETE PILE  
USING DRILLING MUD (BENTONITE SLURRY)

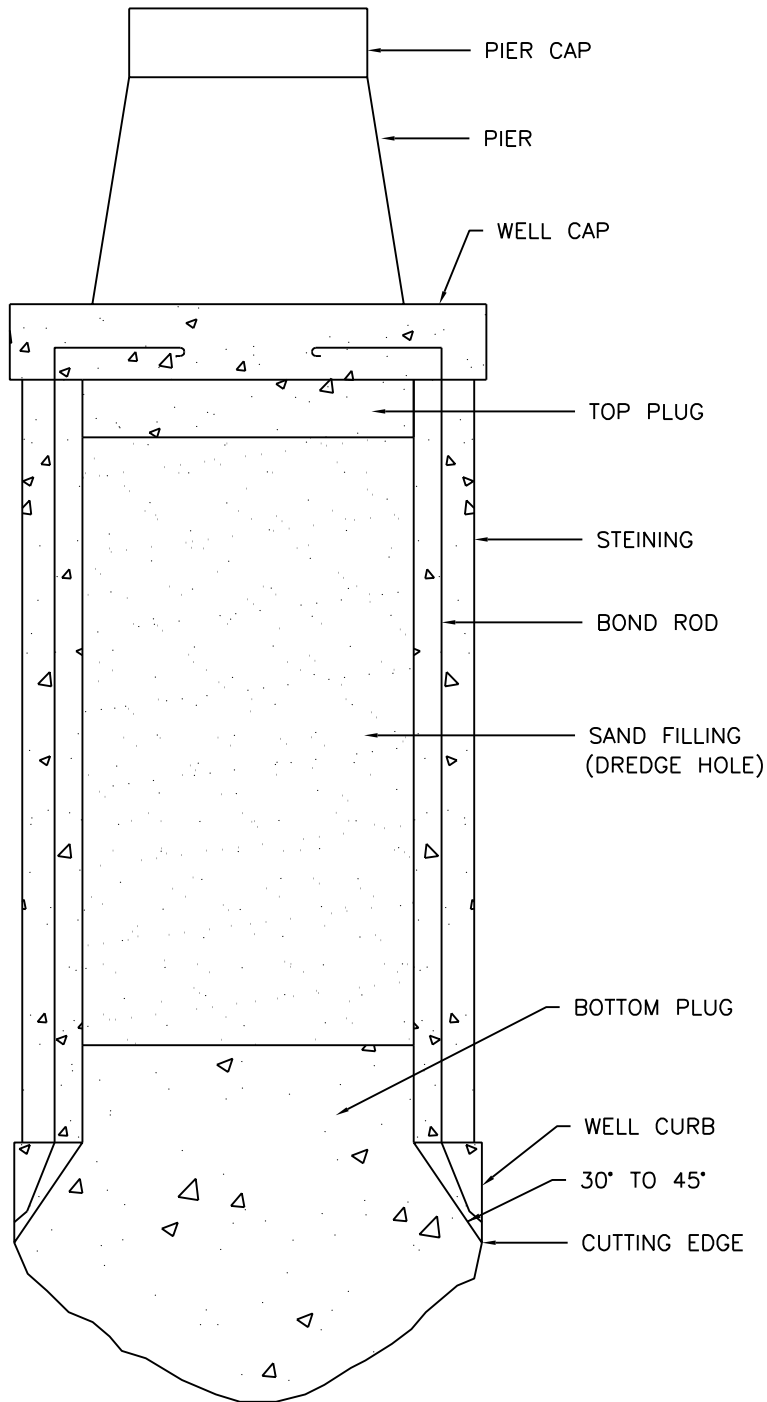

कूप नींव (वृत्ताकार) की विशिष्ट  
अनुप्रस्थ काट

TYPICAL CROSS SECTION OF  
A WELL FOUNDATION (CIRCULAR)

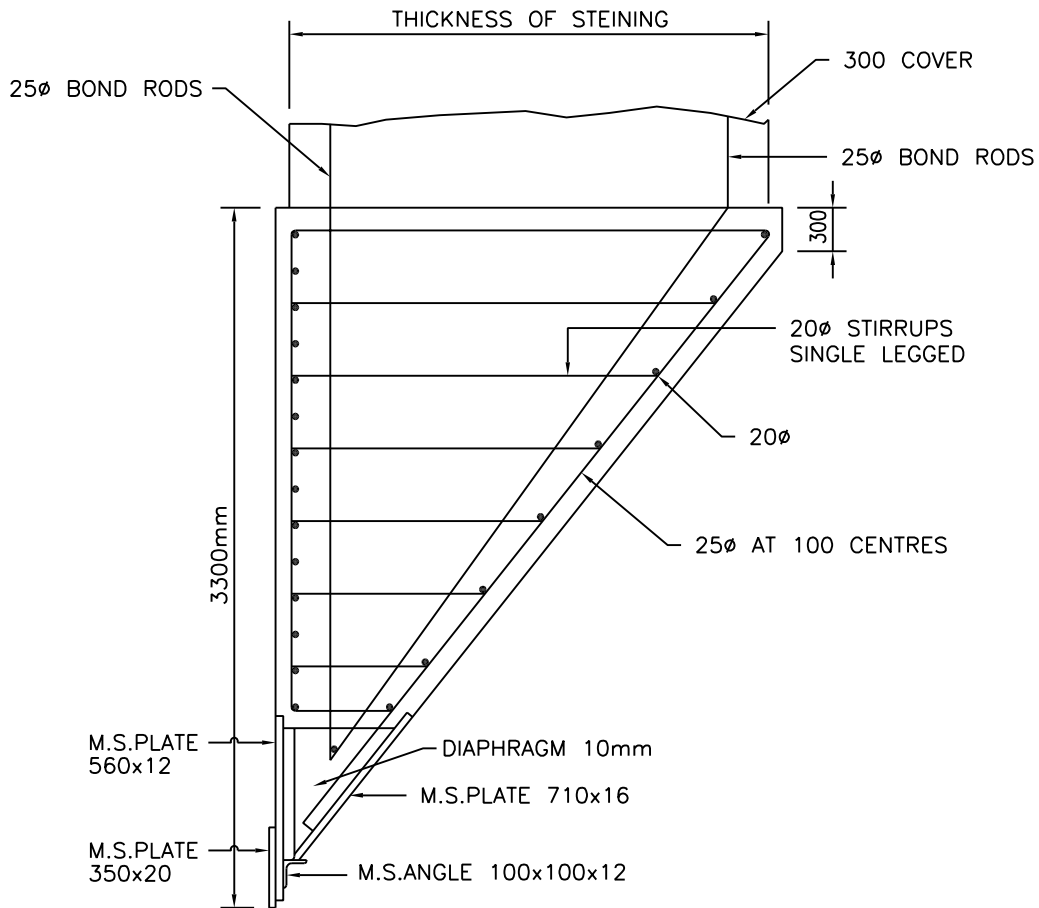

कर्तन कोर सहित विशिष्ट प्रबलित  
सीमेंट कंक्रीट कूप पाट

TYPICAL R.C.C. WELL CURB  
INCLUDING CUTTING EDGE

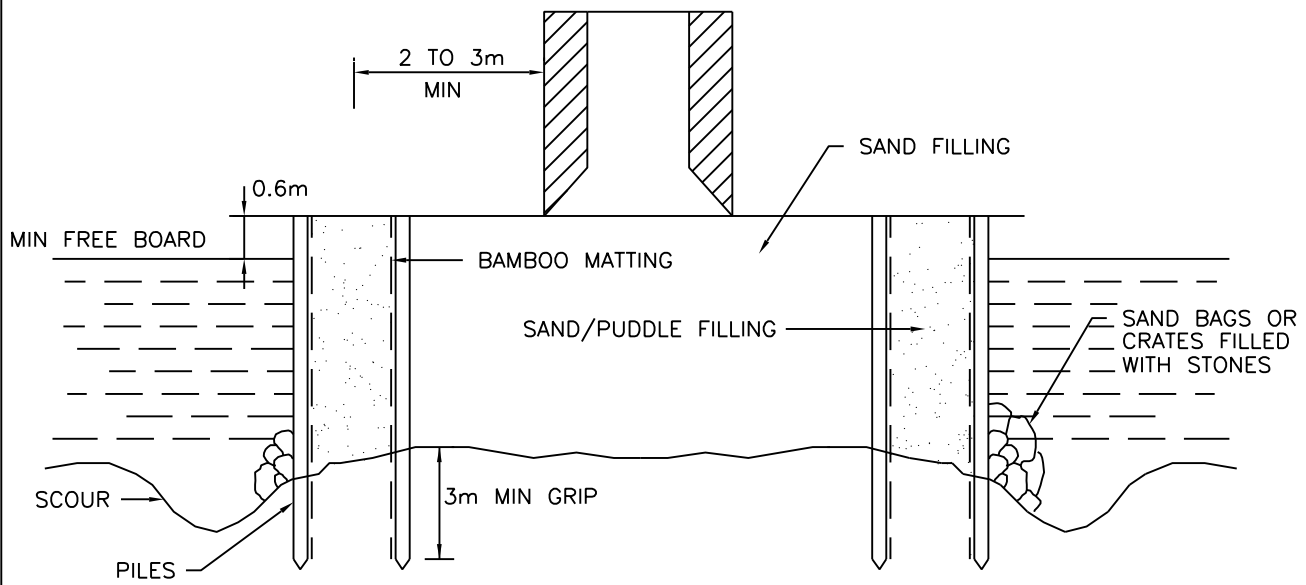

जल में कूप के निर्माण के लिए द्वीप

ISLAND FOR CONSTRUCTION OF WELL IN WATER

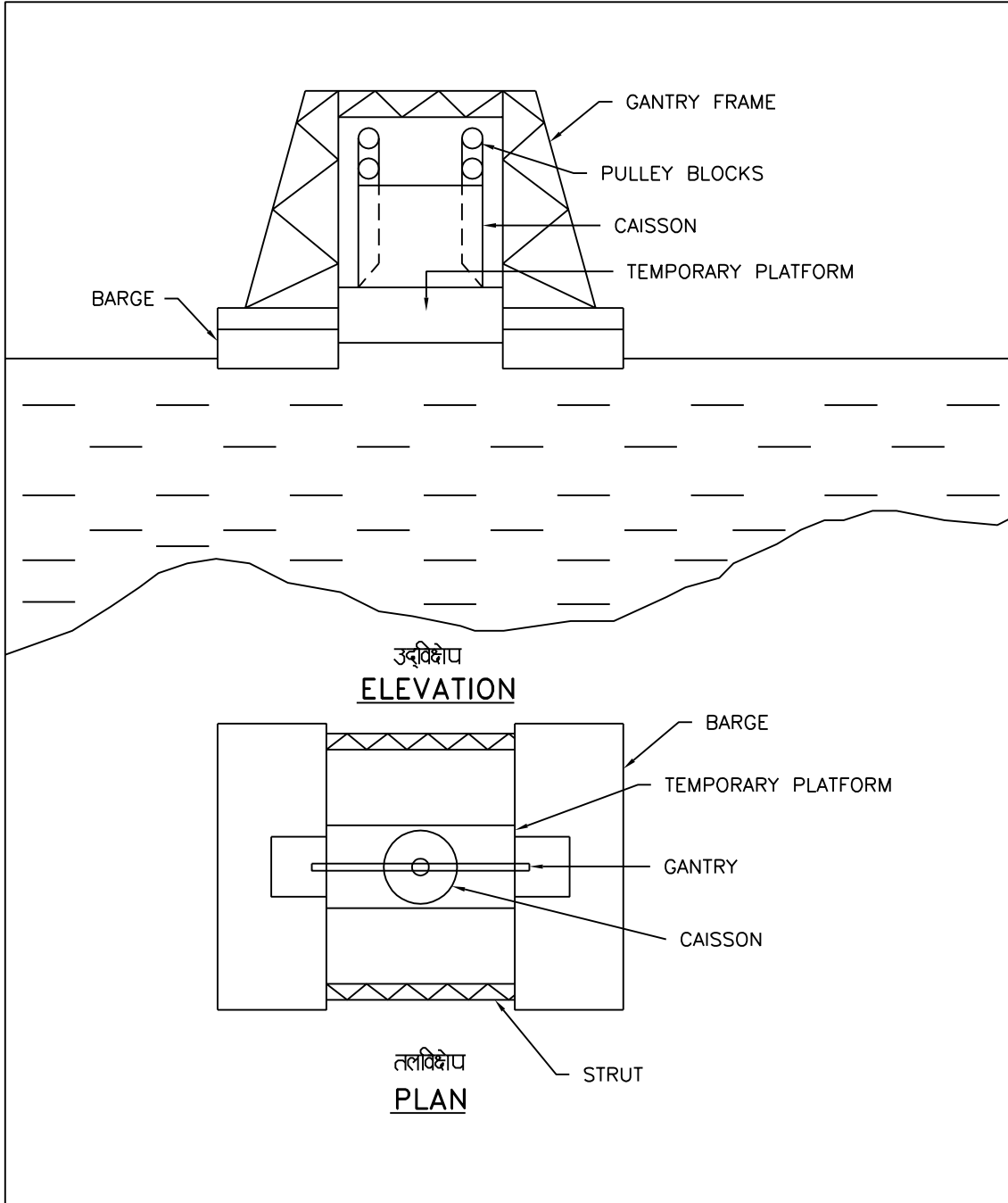

पाये के स्थान पर कैसन  
का सज्जीकरण  
ASSEMBLY OF CAISSON  
AT THE SITE OF PIER



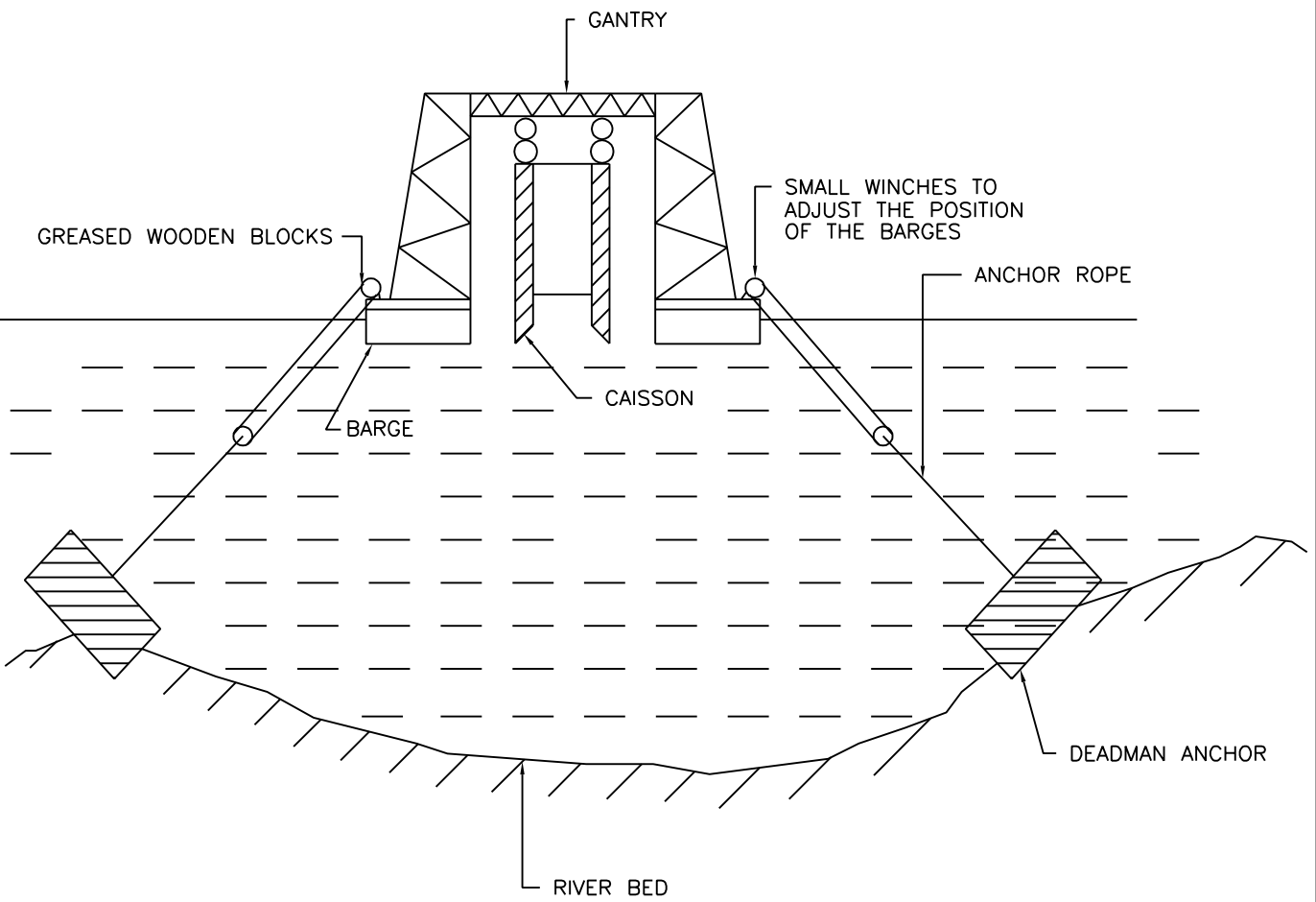

कैसनों को भूमि पर रखने की व्यवस्था  
ARRANGEMENT FOR GROUNDING OF CAISSONS

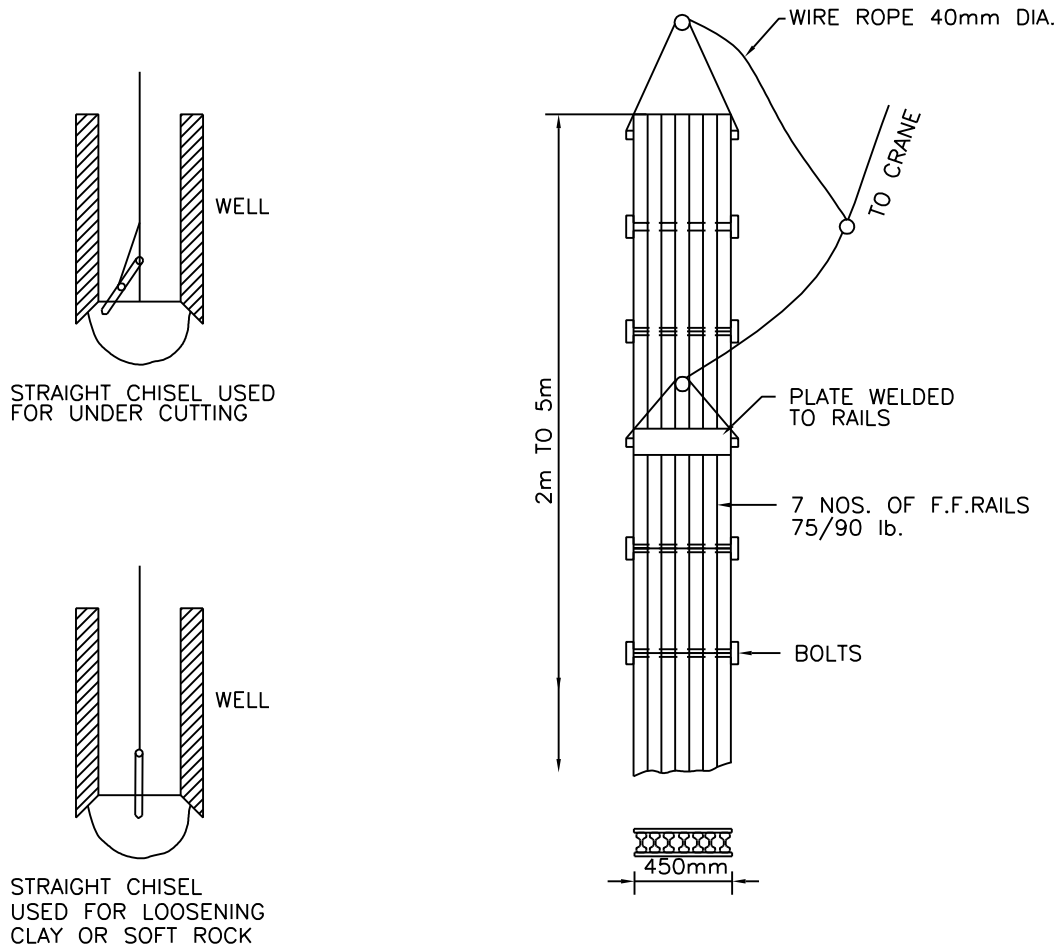

तलविक्षेप  
PLAN

कुएं की खुदाई के लिए प्रयुक्त  
रेल छैनी की किस्म  
TYPE OF RAIL CHISELS  
USED IN WELL SINKING

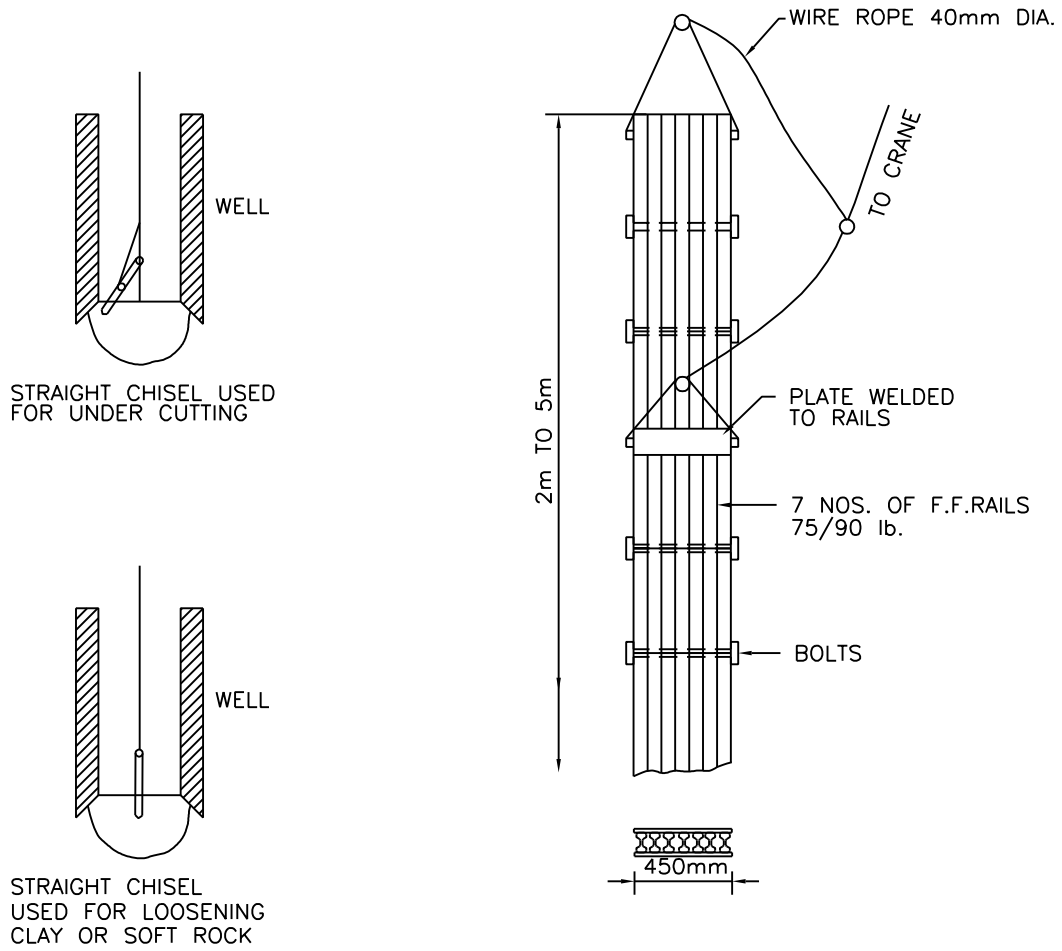

तलविक्षेप  
PLAN

कुएं की खुदाई के लिए प्रयुक्त  
रेल छैनी की किस्म  
TYPE OF RAIL CHISELS  
USED IN WELL SINKING

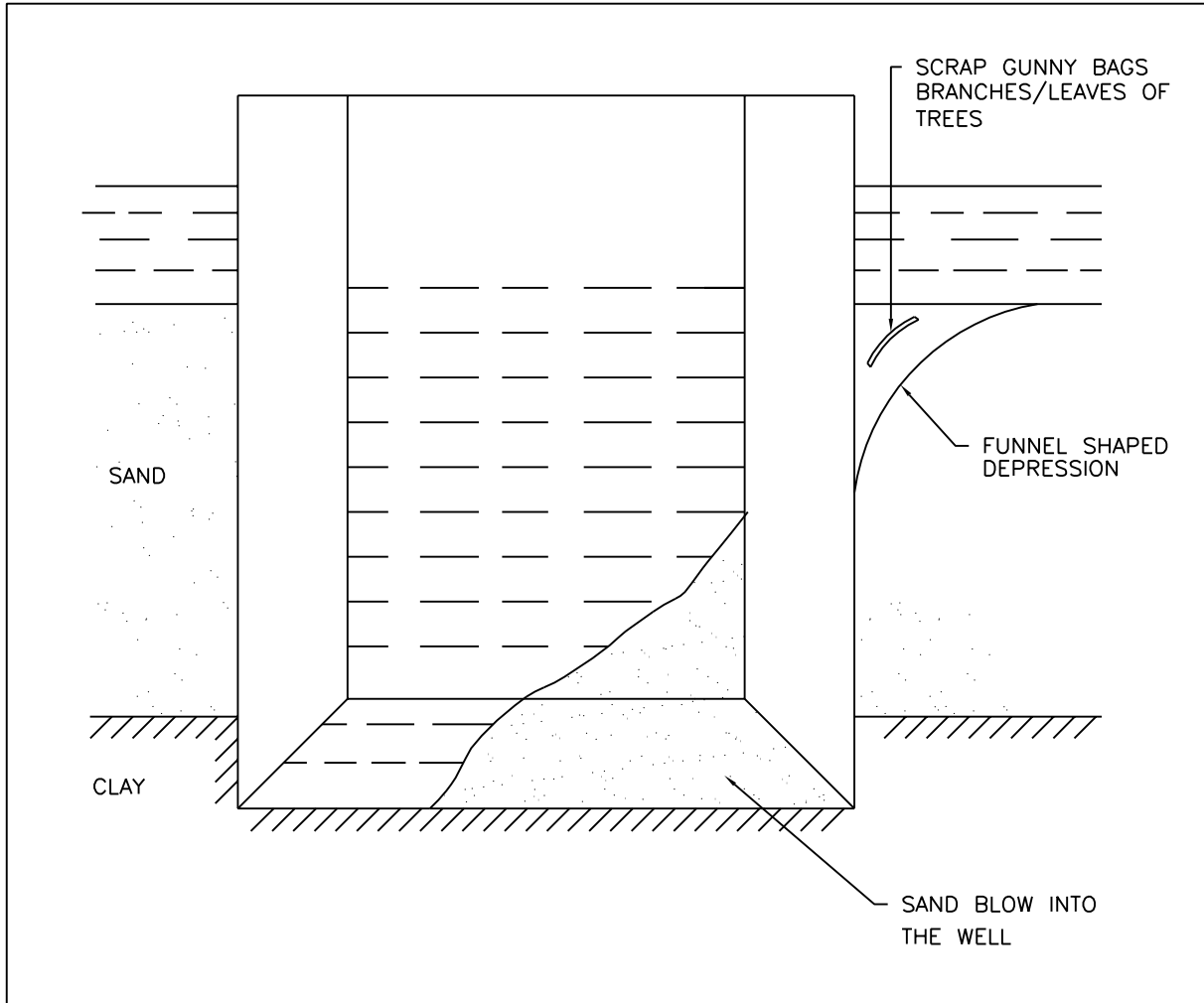

कुएं में बहती हुई रेत  
SAND BLOW IN A WELL

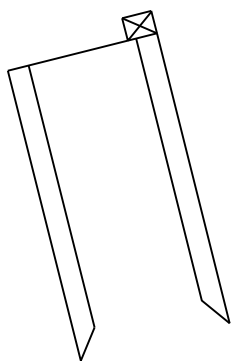

KENTLEDGE IS HELPING TO REDUCE THE TILT

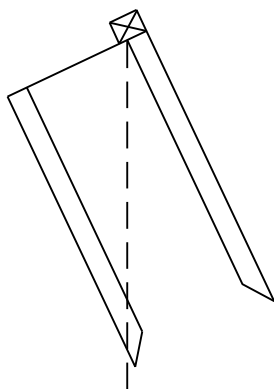

KENTLEDGE IS HELPING TO INCREASE THE TILT

केंटलेज का प्रयोग कर झुकव ठीक करने की विधि

METHOD OF TILT CORRECTION BY USING KENTLEDGE

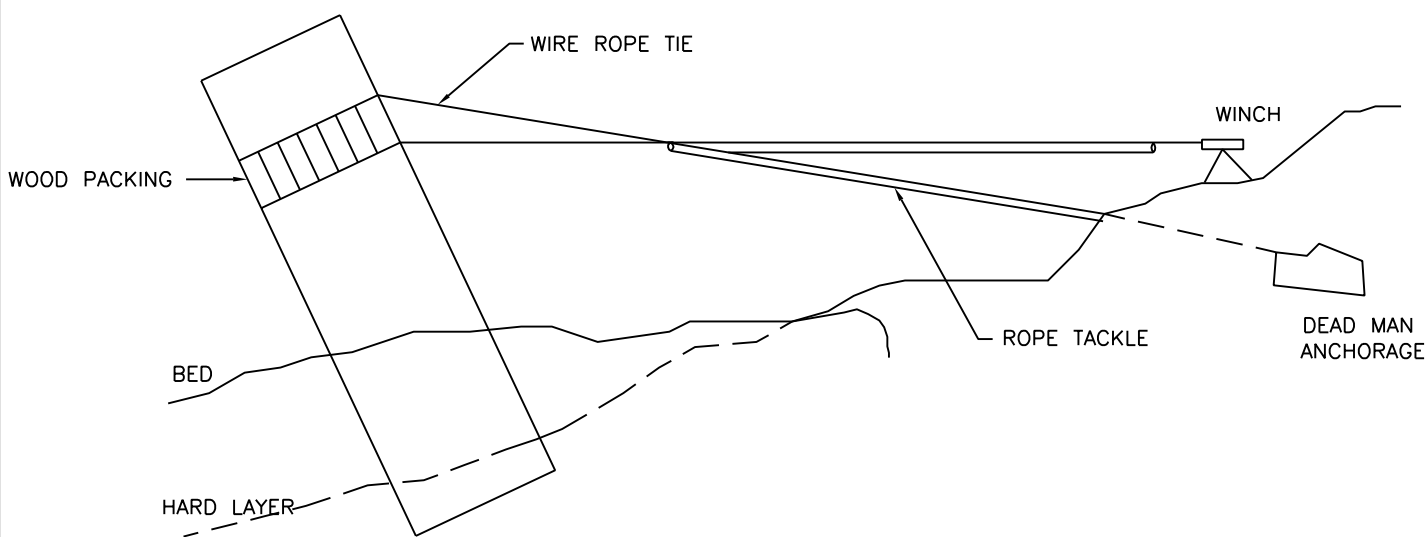

विचिंग का प्रयोग कर झुकव ठीक करने की विधि

METHOD OF TILT CORRECTION BY USING WINCHING

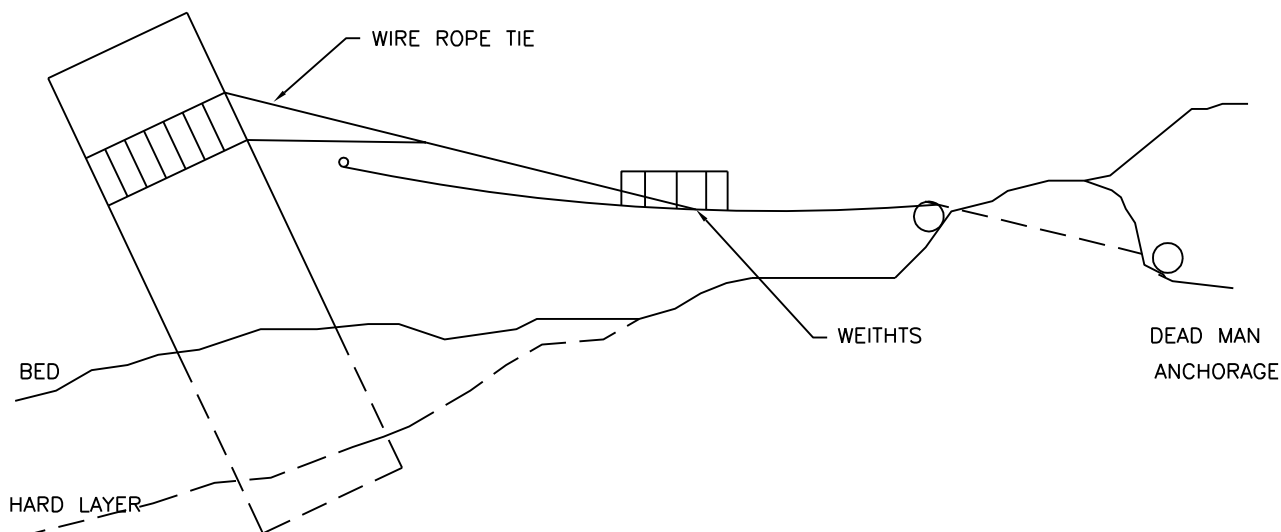

टाइ पर भार द्वारा झुकव ठीक करने की विधि

METHOD OF TILT CORRECTION BY WEIGHTING THE TIE

झुकव ठीक करने की विधि

METHOD OF TILT CORRECTION



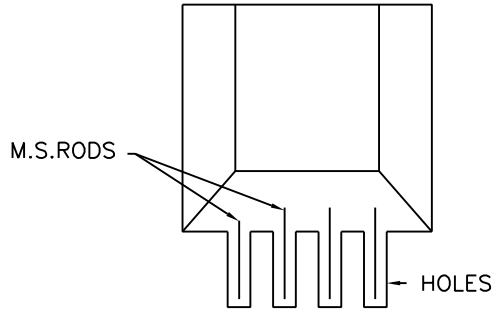

ROCK  
(a)

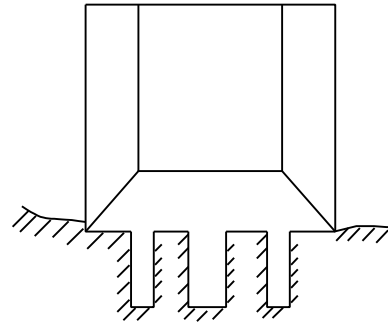

ROCK  
(b)

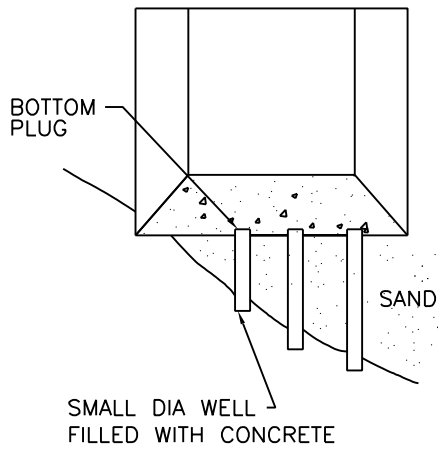

(c)

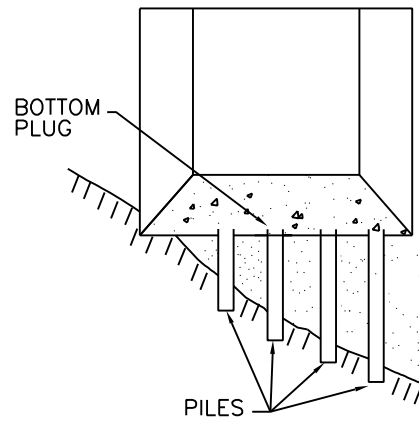

(d)

वट्टान पर कुएँ की नींव  
FOUNDING OF WELLS ON ROCK

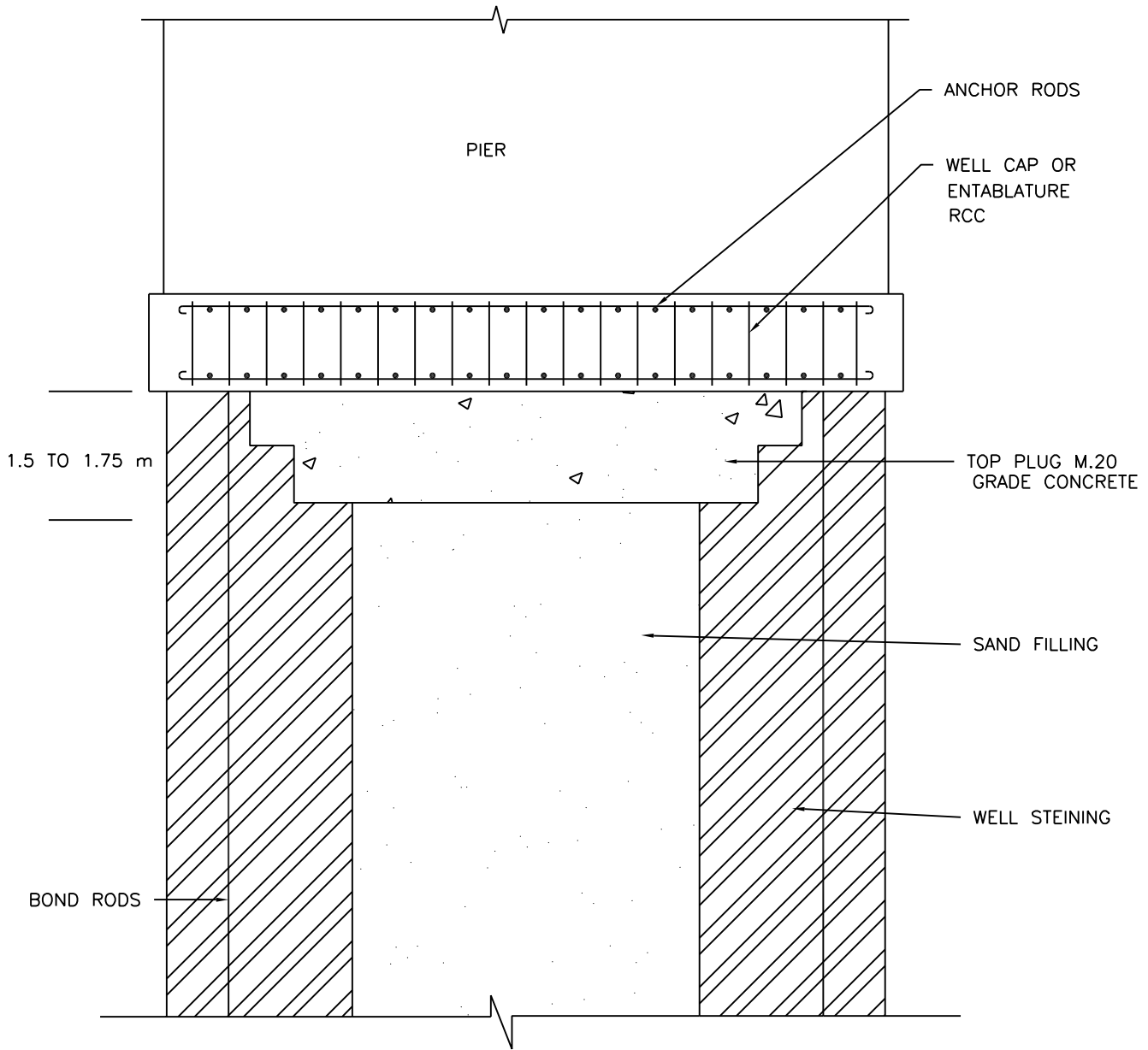

ऊपरी प्लग एवं कुएं की कैप (प्रस्तर)

TOP PLUG AND WELL CAP (ENTABLATURE)



दक्षिण मध्य रेलवे  
SOUTH CENTRAL RAILWAY

LOCATION/KILOMETRES	365.00 366.86 368/10-11	376.90 MARANGAL	389.21 CHINTA- -LAPALLI	396.86 FELGUR	406.41 MEKONDA	415.89 NTEKANNE	422.03 KESAMUDRAM	437.07 MAHBUBABAD	441/89	451/2-3
BRIDGE No	463		511						591	611
SPANS	1x0.91m		3x610						1x3.66	1x3.66
TYPE OF BRIDGE	T T		PG						A	A
YEAR OF CONSTRUCTION	1886.89		1886.89						1886.89	1886.89
NATURE OF DISTRESS	SB-4								SS1	SS2
CATEGORY OF DISTRESS	I		II						I	II
SPEED RESTRICTION IF ANY IN KMPH	SD								10	10
DETAILS OF WORKS TO BE DONE	RB		RG						CS	RB
APPROXIMATE COST OF REHABILITATION (IN LAKHS)	1.0		3.0						2.0	1.0
INCLUDED IN W.P.	8.3.84		NYI						8.3.84	NYI

2.1 नींव

2.1 FOUNDATION

F1 WEAK/CORRODED/CRACKED CI SCREW AND STEEL PILES.  
F2 SETTLEMENT OF FOUNDATION IN PIER / ABUTMENTS

F3 EXCESSIVE SCOUR AROUND PIER / ABUTMENTS.

2.2 उपसंरचना

2.2 SUB STRUCTURE

SB1 TILTED PIERS AND ABUTMENTS.

SB2 CRACKED / SHAKEN BED BLOCKS.

SB3 BULGING OF ABUTMENTS.

SB4 CRACKS/CRUSHING OF MASONRY BELOW THE BED BLOCK.

SB5 CRACKS IN RETURN WALLS & WING WALLS.

SB6 BULGING IN RETURN WALLS & WING WALLS.

SB7 EXCESSIVE WEATHERING OF STONE / BRICK MASONRY.

SB8 LONGITUDINAL/TRANSVERSE/DIAGONAL CRACKS IN ARCHES.

SB9 EXCESSIVE SPALLING OF CONCRETE/MORTAR.

SB10 BULGING OR SEPARATION OF SPANDREL FROM ARCH BARREL.

SB11 DISTORTION OF ARCH.

2.3 अधि संरचना

2.3 SUPER STRUCTURE

SS1 PROGRESSIVE LOSS OF CAMBER IN GIRDERS.

SS2 CRACKS IN RCC/PSC MEMBERS.

SS3 CRACKS/HEAVY CORROSION OF LOAD BEARING MEMBERS OF STEEL GIRDERS.

SS4 SNAPPING OF RIVETS.

SS5 OBSERVABLE DEFORMATION OF ARCH RING.

SS6 LOOSE RIVETS OF MORE THAN 20% AT ANY JOINT.

SS7 CRACKS IN BEARINGS.

3.0 किए जाने वाले कार्य का ब्यौरा

3.0 DETAILS OF WORK TO BE DONE

RB REBUILDING

ST STRENGTHENING (INCLUDES JACKETTING)

RG REGIRDERING

CB

CS CHANGING WITH SLAB.

CHANGING/STRENGTHENING OF BED BLOCKS.

4.0 NYI:NOT YET INCLUDED.

SD: STOP DEAD RESTRICTION.

सन्दर्भ  
1. पुलों के प्रकार

REFERENCES  
1. TYPE OF BRIDGES

PSC PRE-STRESSED CONCRETE

TTG THROUGH TRIANGULATED GIRDER

PG PLATE GIRDER

A ARCH

ST SLAB TOP CULVERT

RCS REINFORCED CONCRETE SLAB TOP CULVERTS

CP CAST IRON PIPE

RP REINFORCED CONCRETE PIPE

RCB REINFORCED CONCRETE BEAM

TT TIMBER TOP CULVERT

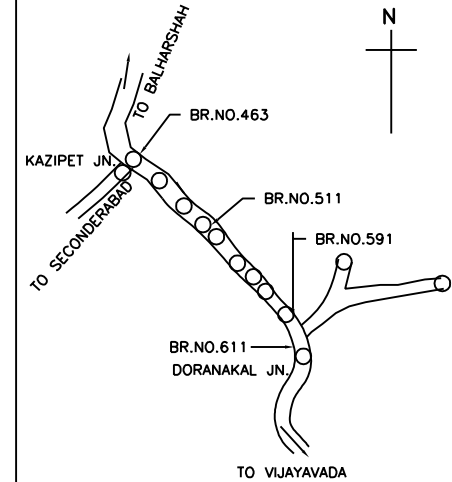

KEY PLAN

नमूना

SAMPLE

आपातित पुल आरेख

DISTRESSED BRIDGE DIAGRAM

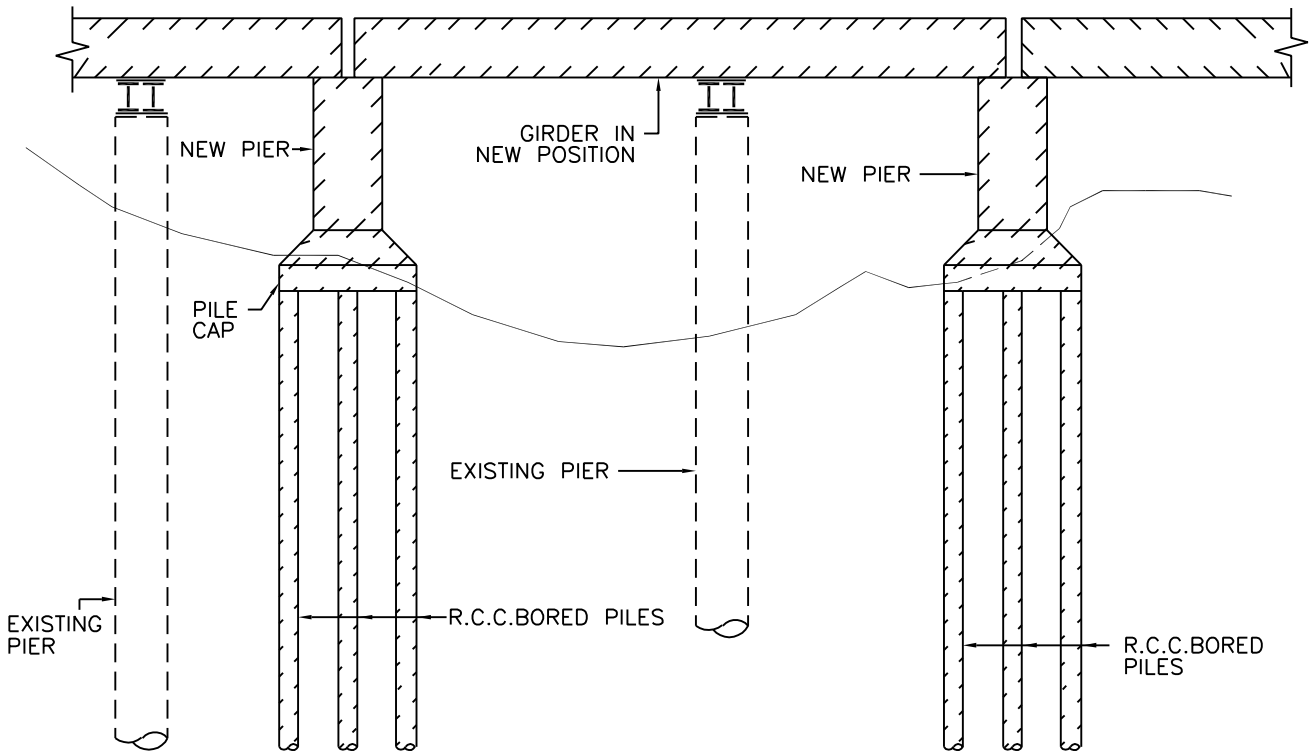

PROPOSALS SHOWN HATCHED

ढलवा लोहे के पेंचदार पाइलों को  
ठिड्रित आर.सी.सी. पाइलों में बदलना  
REPLACEMENT OF CAST IRON  
SCREW PILES BY BORED RCC PILES

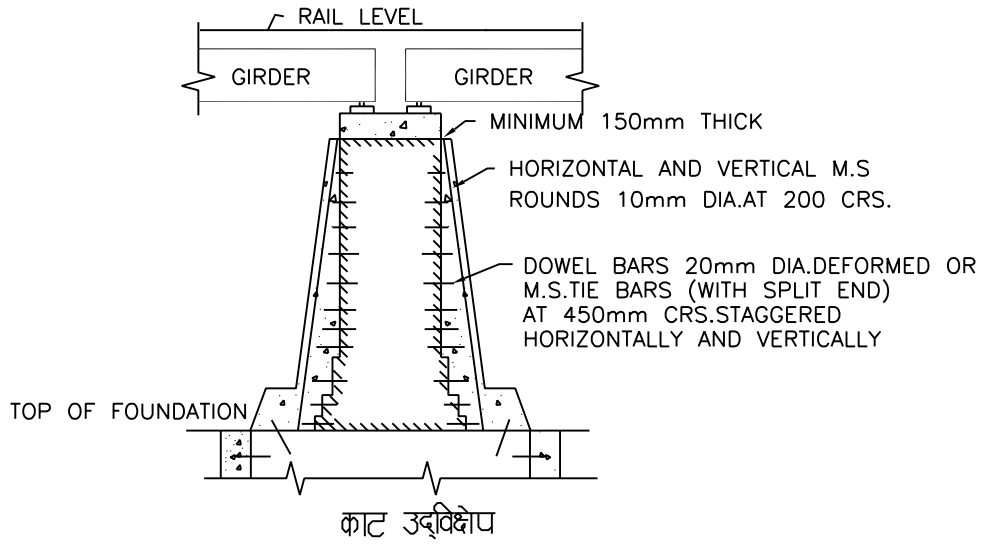

SECTIONAL ELEVATION

5/3(क) जैकेट द्वारा उपसंरचना का सुदृढीकरण  
5/3(a) STRENGTHENING OF SUBSTRUCTURE BY JACKETING

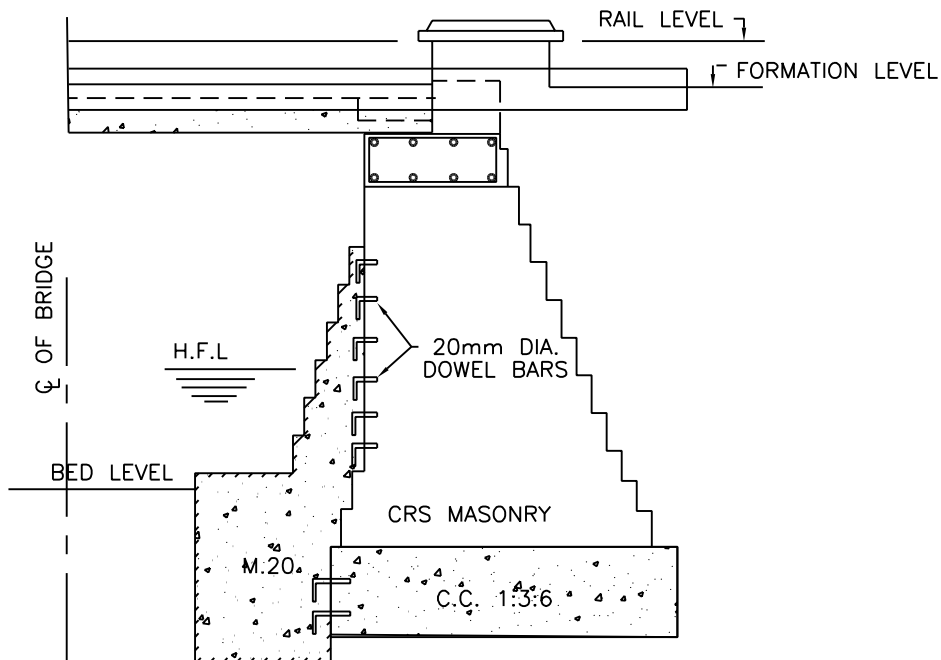

अनुप्रस्थ काट  
CROSS SECTION

PROPOSALS SHOWN HATCHED.

5/3(ख) पोलपार का सुदृढीकरण  
5/3(b) STRENGTHENING OF ABUTMENT

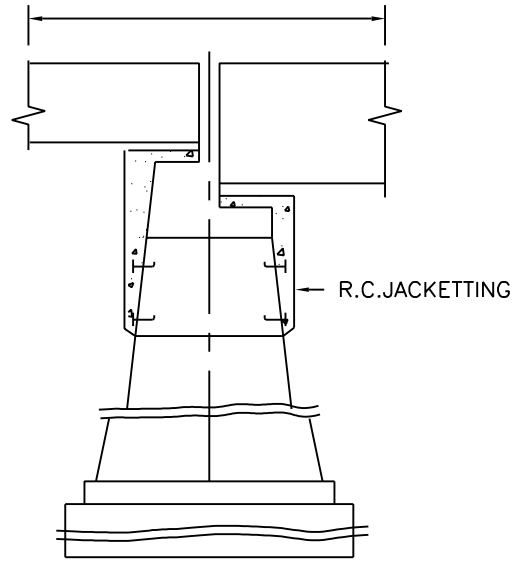

अंश काट उद्विधेप

PART SECTIONAL ELEVATION

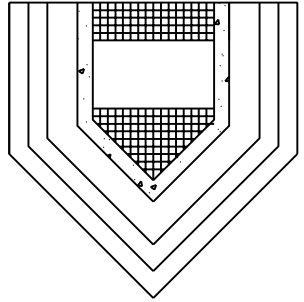

अंशिक तलविधेप  
PART PLAN

(क) आधार खंडों का आवरण  
(a) ENCASING OF BED BLOCKS

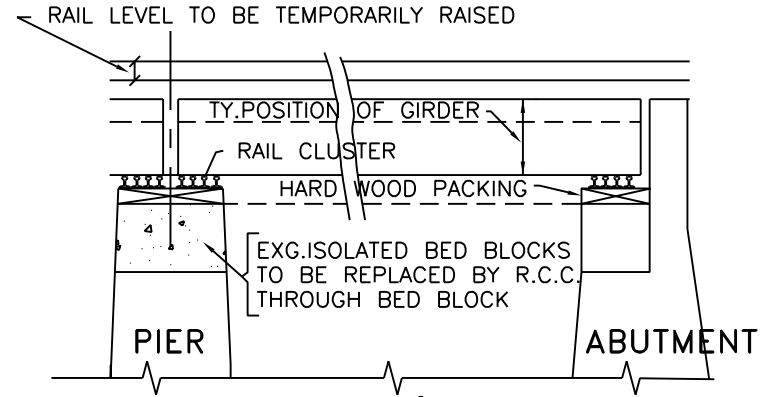

काट उद्विधेप

SECTIONAL ELEVATION

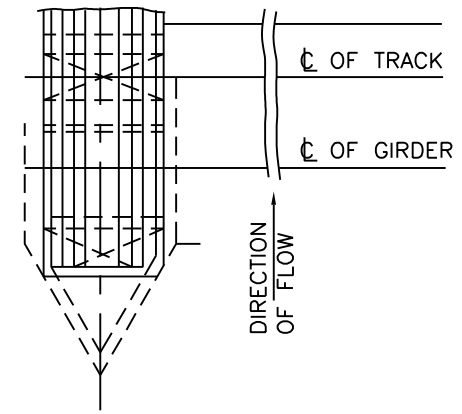

अंशिक तलविधेप

PART PLAN

(ख) आद्योपान्त आधार खंड द्वारा प्रस्थापन  
(b) REPLACEMENT BY THROUGH BED BLOCK

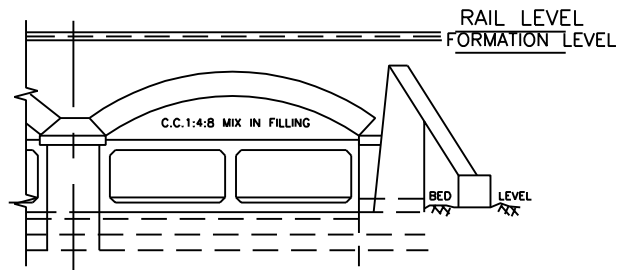

आंशिक उद्दिष्ट  
 PART ELEVATION

क) मेहराब के अंदर आर.सी.सी. बॉक्स का निर्माण  
 a) CONSTRUCTION OF R.C.C. BOX WITHIN ARCH

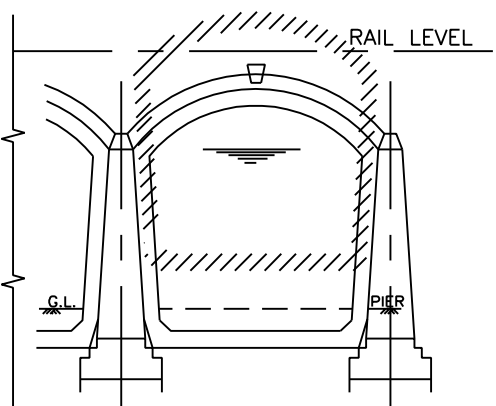

आंशिक काट उद्दिष्ट  
 PART SECTIONAL ELEVATION

ग) मेहराबों का संवरण  
 c) CLOSED RING JACKETING OF ARCHES

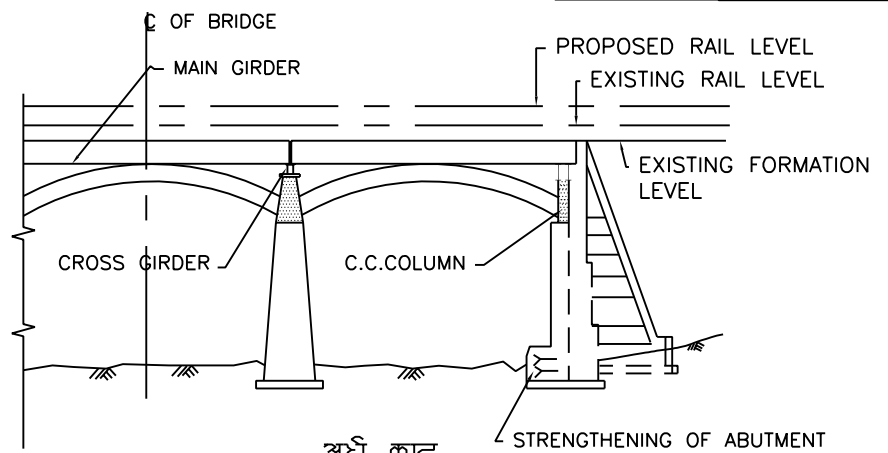

अर्ध काट  
 HALF SECTION

घ) मेहराब पुल का मेहराब खंडित किए बिना, गड्ढे पुल में परिवर्तन  
 e) CONVERSION OF ARCH BRIDGE INTO GIRDER BRIDGE WITHOUT DISMANTLING ARCH

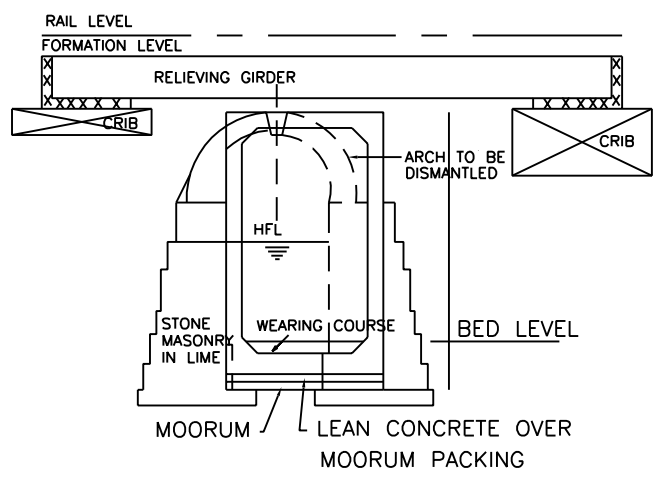

ख) एक पोलपाये का प्रयोग करते हुए आर.सी.सी. बॉक्स का निर्माण  
 b) CONSTRUCTION OF R.C.C. BOX USING ONE ABUTMENT

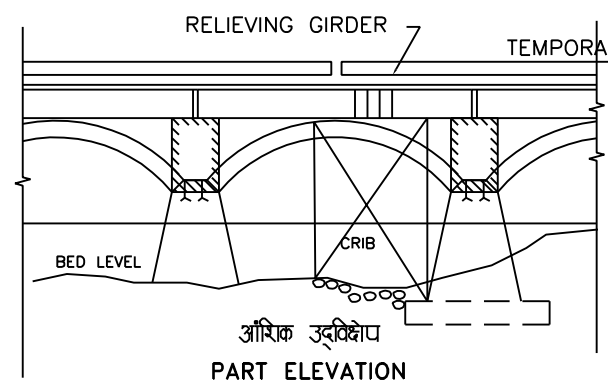

आंशिक उद्दिष्ट  
 PART ELEVATION

घ) पायों को उठाते हुए (मेहराब खंडित कर) मेहराब पुल का सपाट शीर्ष में परिवर्तन  
 d) CONVERSION OF ARCH INTO FLAT TOP BY RAISING PIERS (DISMANTLING ARCH)

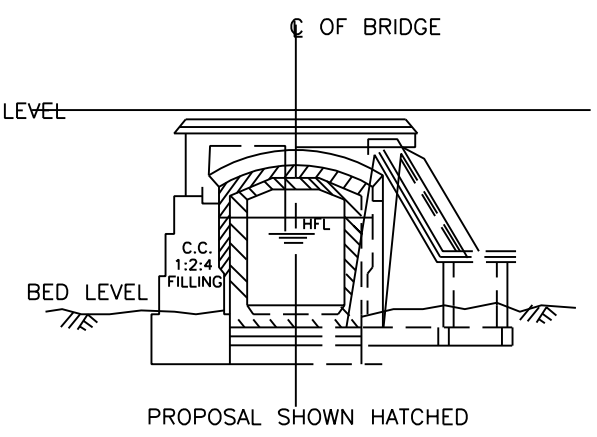

PROPOSAL SHOWN HATCHED

व) काट उद्दिष्ट वलित पट्टिका के समान पेटे पुलिया  
 f) SECTIONAL ELEVATION FOLDED PLATE TYPE BOX CULVERT

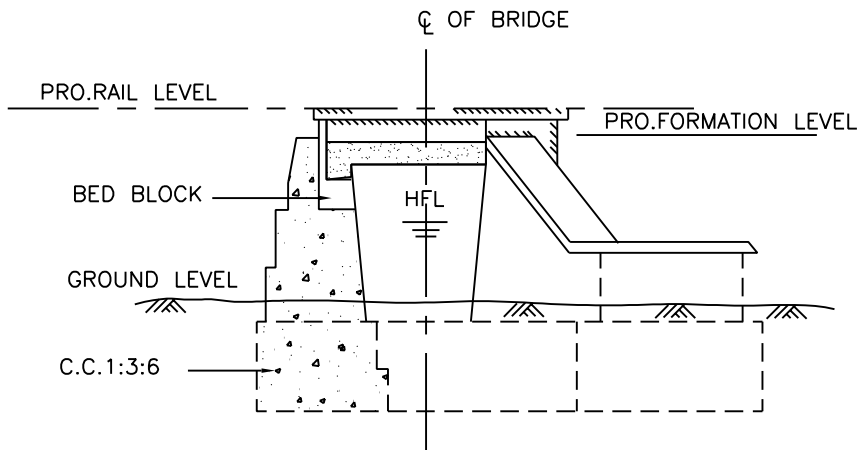

(क) पात के साथ स्लैब का प्रयोग

(a) USE OF SLAB WITH DROPS

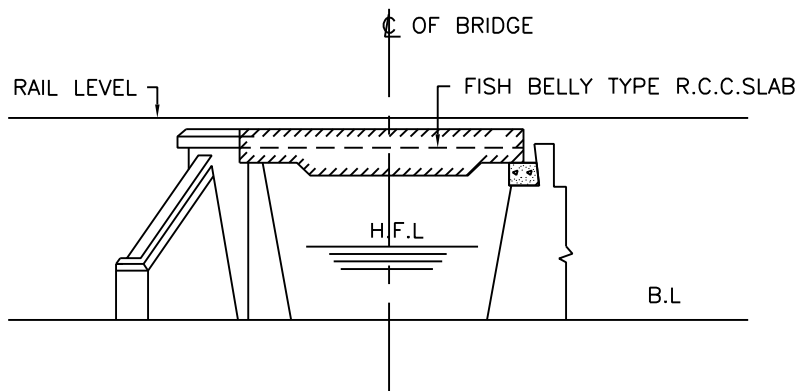

अर्ध काट उद्दिष्ट

HALF SECTIONAL ELEVATION

(ख) गुंडाकार सिरा स्लैब का प्रयोग

(b) USE OF TAPERED END SLAB

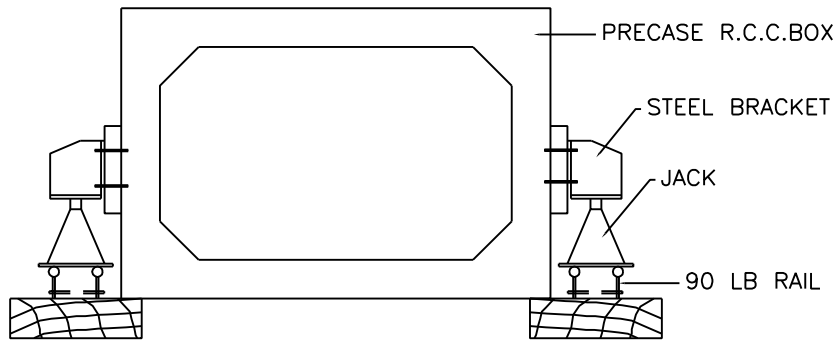

काट सी-सी  
SECTION 'C-C'

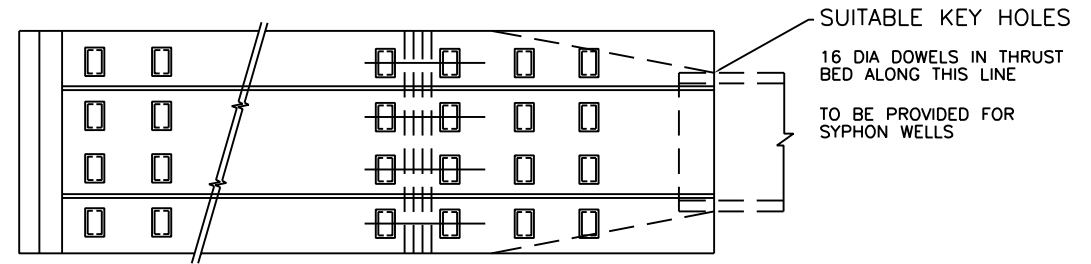

तलविक्षेप  
PLAN

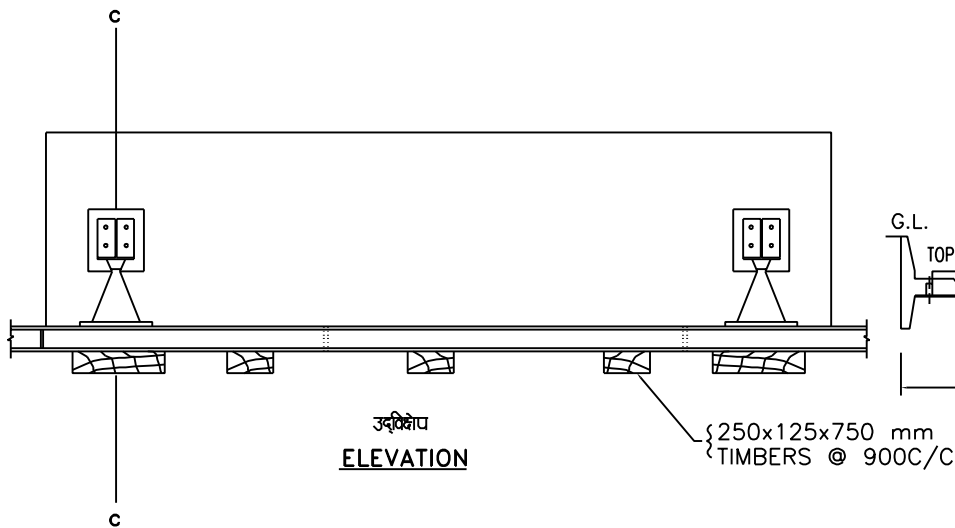

उद्विक्षेप  
ELEVATION

पूर्व दलित आर.सी.सी. बॉक्सों के  
लिए अवतरणी व्यवस्था  
LAUNCHING ARRANGEMENT FOR  
PRECAST R.C.C. BOXES

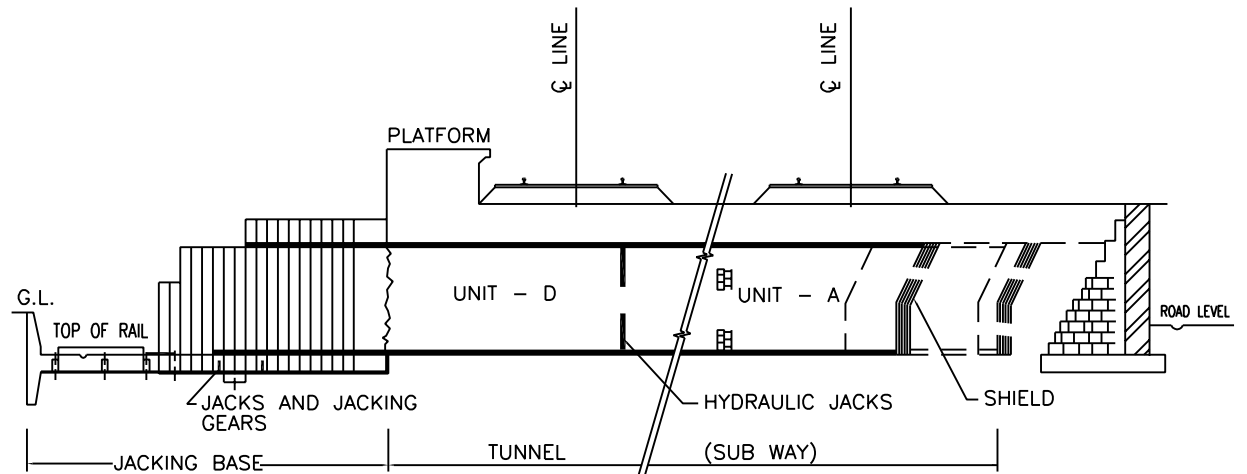

अनुप्रस्थ काट  
CROSS SECTION

बॉक्स पुरिग तकनीक  
BOX PUSHING TECHNIQUE

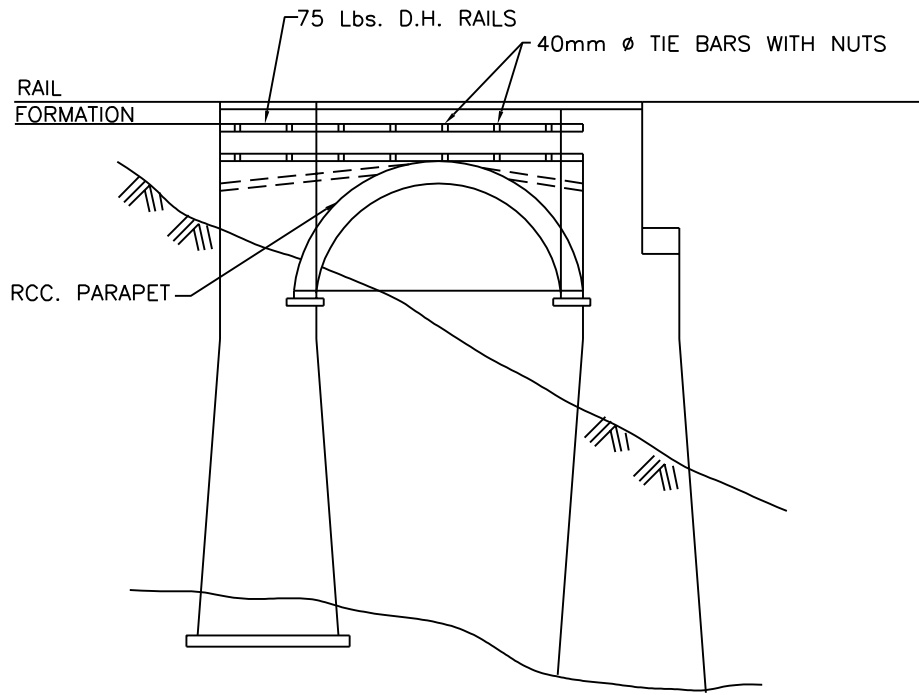

उद्विष्ट  
**ELEVATION**

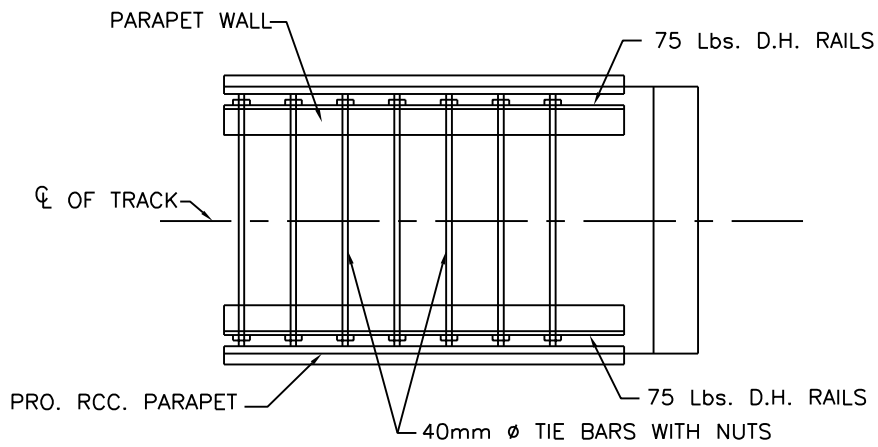

तलविष्ट  
**PLAN**

मुंडेर उभार को नियंत्रित रखने की व्यवस्था  
**ARRANGEMENT FOR HOLDING THE PARAPET BULGE**



# रेल पुलों में अपनाए गए पायों की किस्में

## TYPES OF PIERS ADOPTED IN RAILWAY BRIDGES

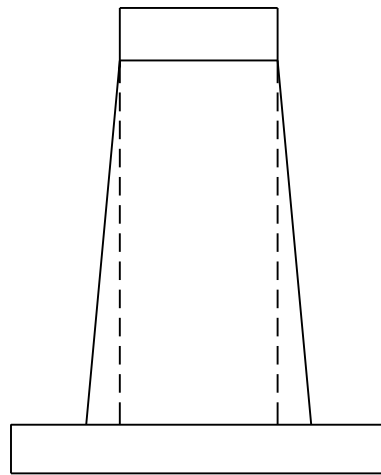

साधारण कंक्रीट पायों  
**MASS CONCRETE PIER**

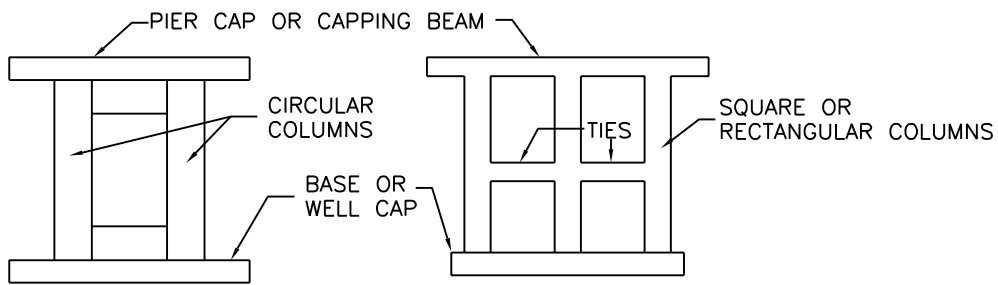

टंडियों सहित सर्कुलर स्तंभ  
**CIRCULAR COLUMNS WITH TIES**

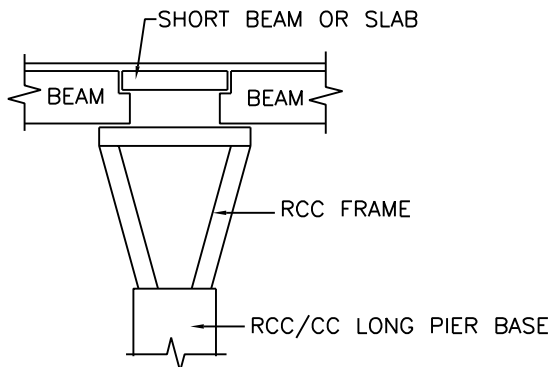

आर सी सी फ्रेम किस्म के पाए  
**RCC FRAMED TYPE PIER**

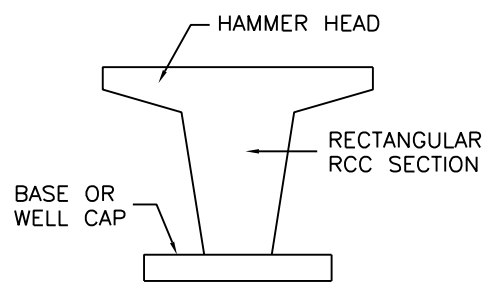

हैमर शीर्ष प्रकार का पाया  
**HAMMER HEAD TYPE OF PIER**

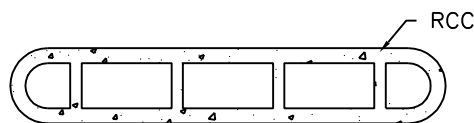

HOLLOW OR FILLED WITH LIGHT CONCRETE  
सेल्युलर प्रकार का पाया  
**CELLULAR TYPE PIER**

क) विभिन्न प्रकार के षीलपाए

**(a) DIFFERENT TYPES OF ABUTMENTS**

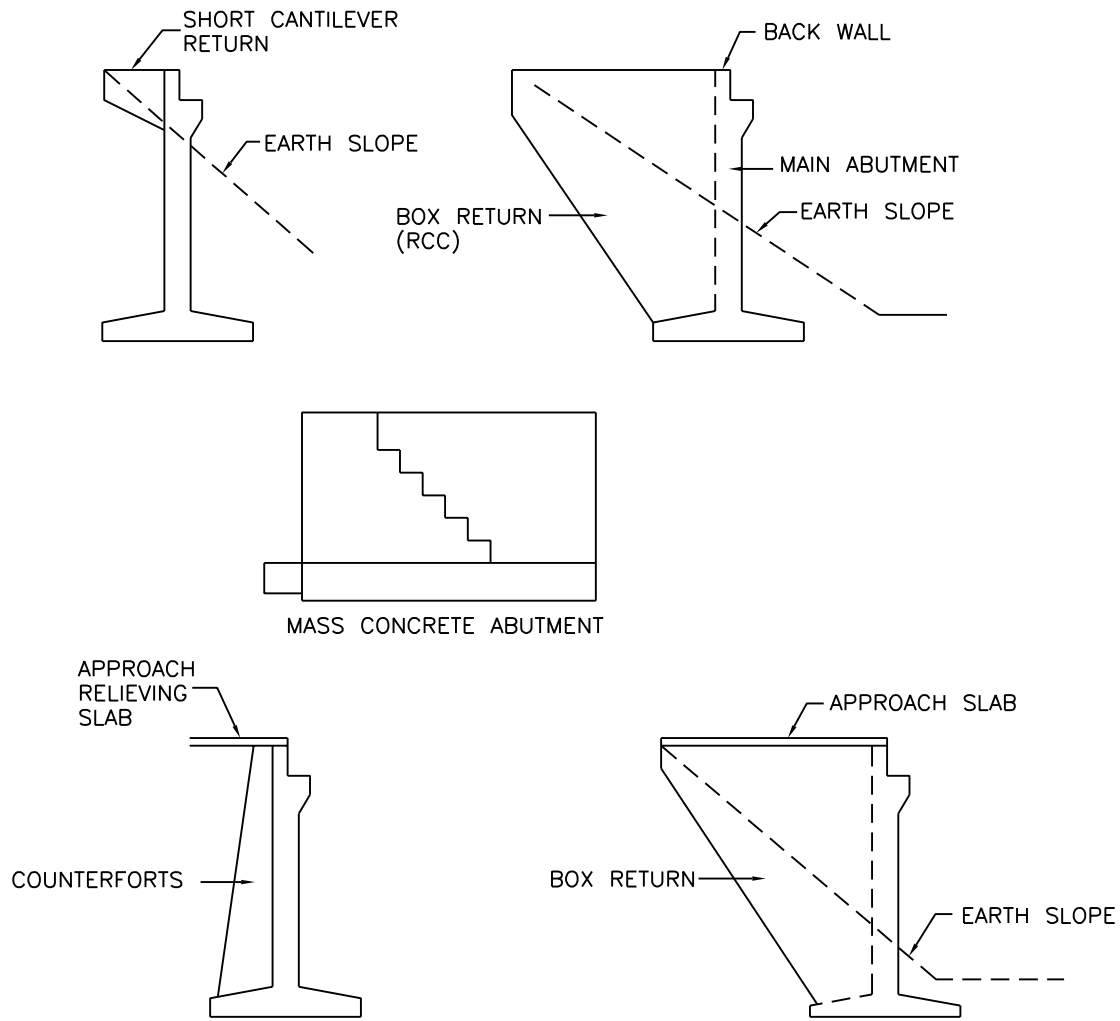

ख) विभिन्न प्रकार के विंग मित्तियां

**(b) DIFFERENT TYPES OF WING WALLS**

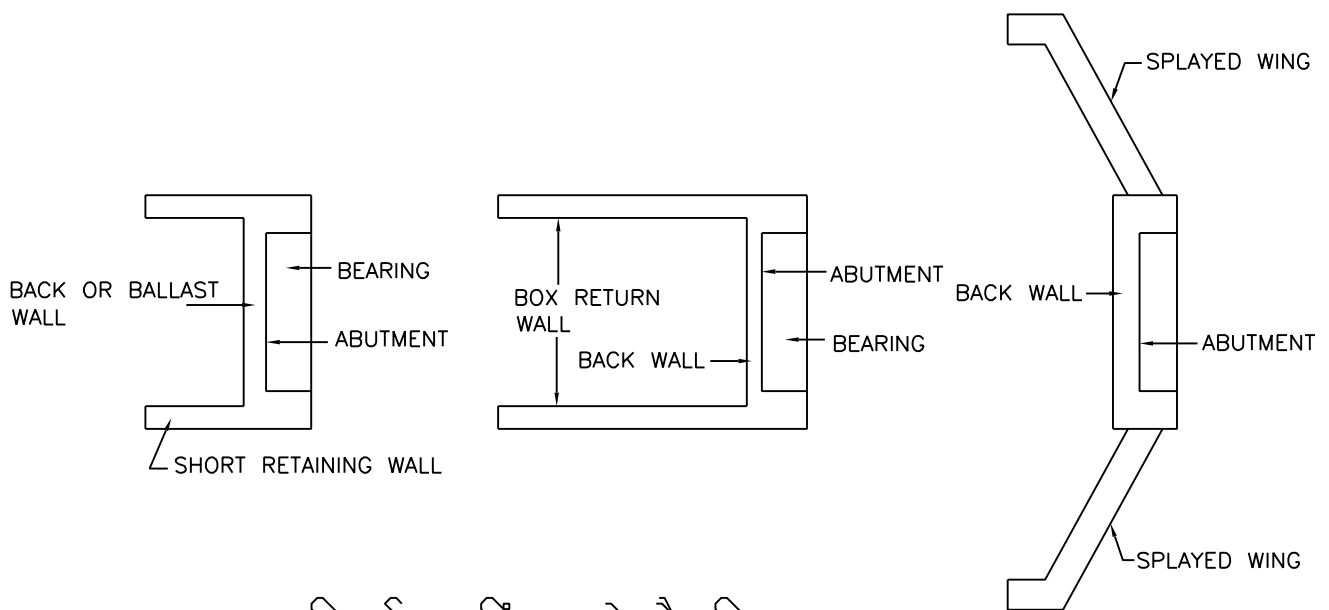

रिटर्न्स/विंग्स के वैकल्पिक प्रकार  
**ALTERNATIVE TYPES OF RETURNS/WINGS**

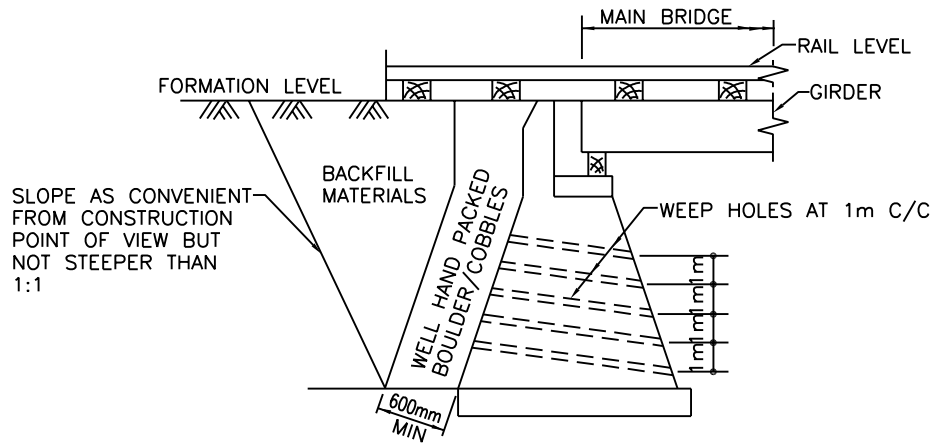

बैकफिल सामग्री तथा वीप छिद्रों का ब्यौरा

DETAILS OF BACKFILL MATERIALS & WEEP HOLES

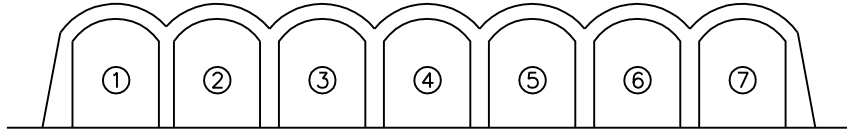

स्पैनों के अंकन दर्शाने वाला उद्दिष्ट

**ELEVATION SHOWING NUMBERING OF SPANS**

(क) बहुविध स्पैन पुल में मेहराब निर्माण का क्रम

**(a) SEQUENCE OF BUILDING ARCHES IN A MULTIPLE SPAN BRIDGE**

STAGE	ERECT SHUTTERING FOR CASTING THEREAFTER	DIMANTLING SHUTTERING
I	2,1,3	-
II	-	1,2
III	4,5	-
IV	-	3,4
V	6,7	-
VI	-	5,6,7

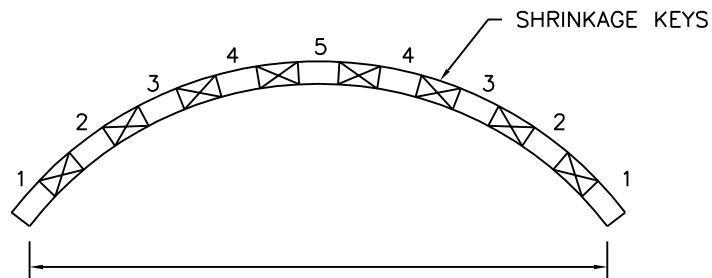

(ख) मेहराब में कंक्रीट करने का क्रम

**(b) SEQUENCE OF CONCRETING IN AN ARCH**

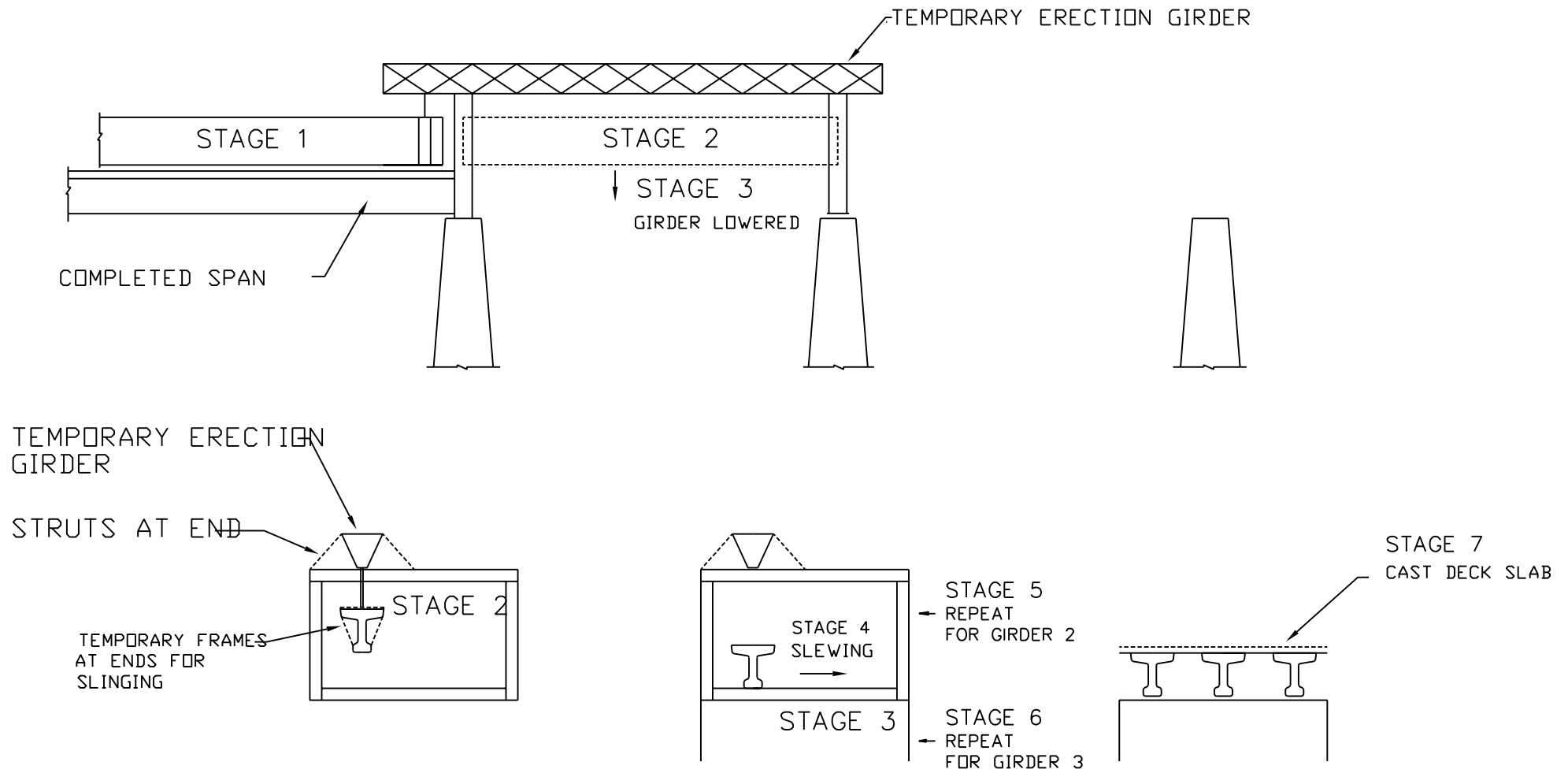

(क) प्रत्येक प्री-कास्ट गर्डरों का अक्षरण एवं बाजु में विस्थापन

(a) LAUNCHING INDIVIDUAL PRECAST GIRDERS AND SIDE SLEWING

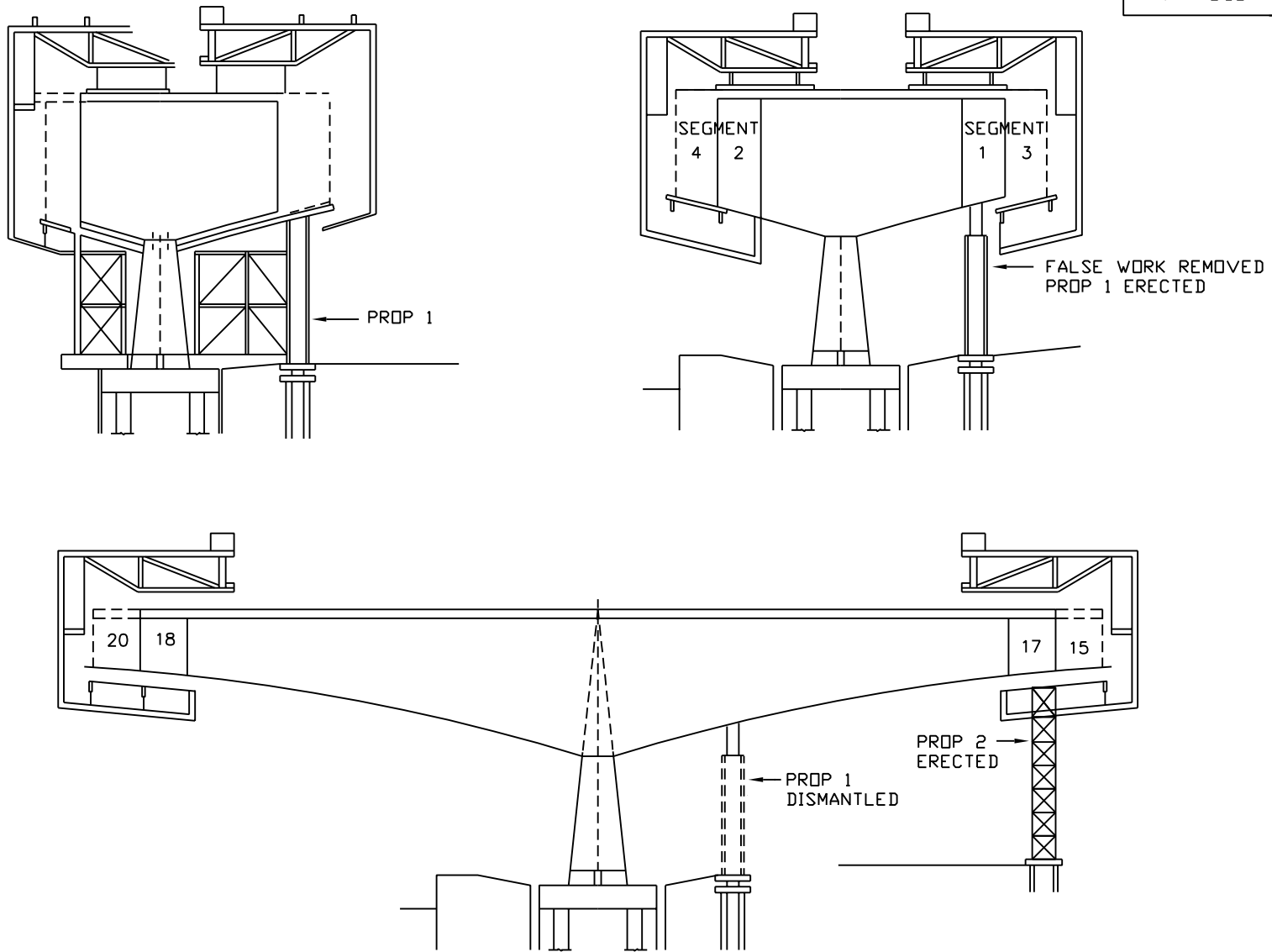

(ख) निर्माण स्थल में कैन्टिलीवर प्रणाली

(b) CANTILEVER METHOD – IN SITE CONSTRUCTION

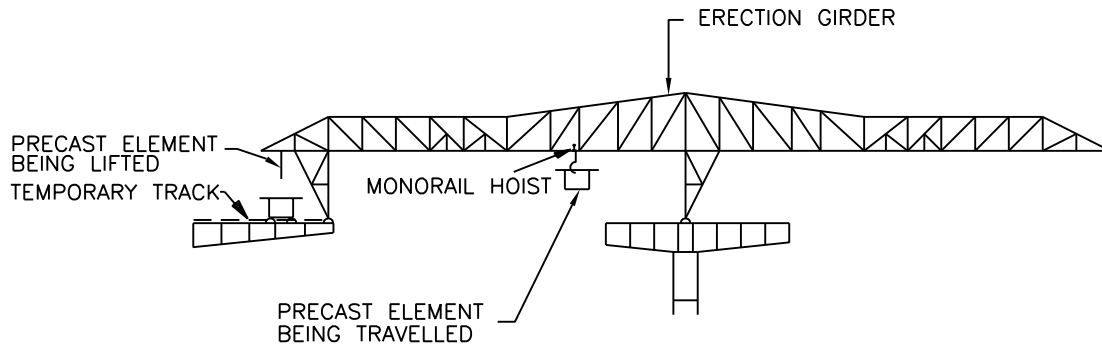

(क) पूर्ण निर्मित खण्डों का उपयोग करते हुए  
निर्माण की कैंटिलीवर पध्दतियां

(a) CANTILEVER METHODS OF CONSTRUCTION  
ERECTION USING PRECAST ELEMENTS

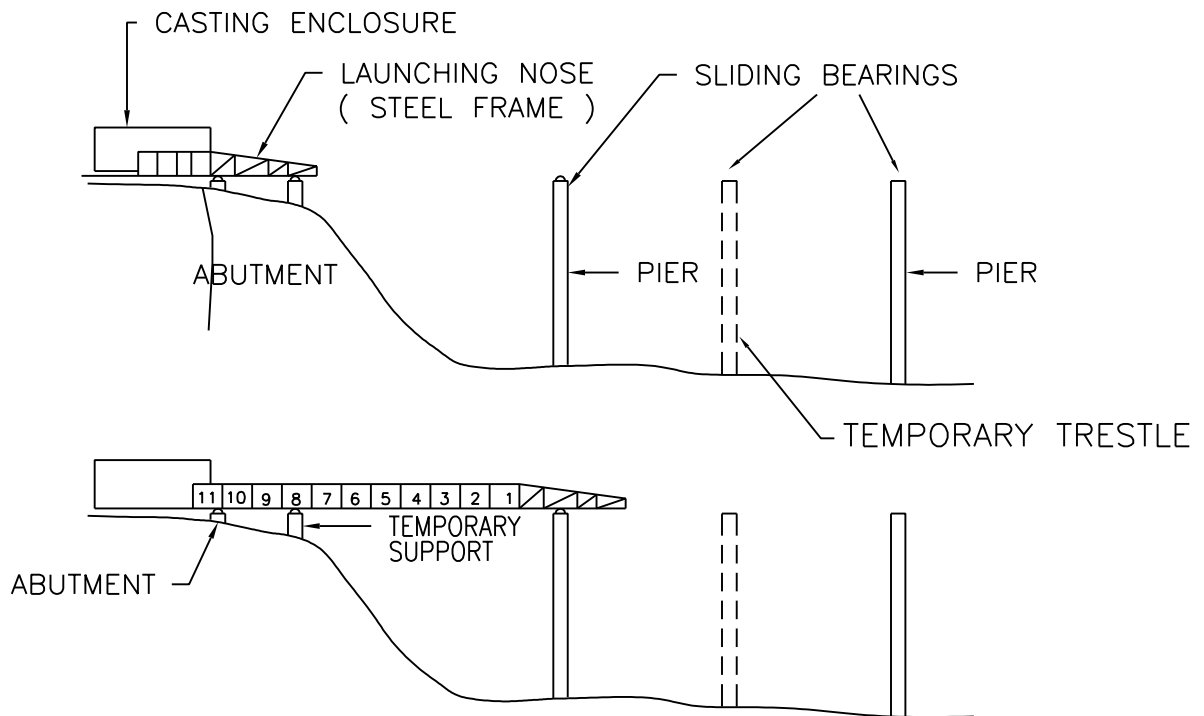

पूर्ण-निर्मित खण्डों सहित वार्धिक अक्षरण पध्दति

(b) INCREMENTAL LAUNCHING METHOD WITH  
PRECAST ELEMENTS

# डेरिक द्वारा गर्डर का उत्पादन ERECTION OF GIRDER BY DERRICK

अनुबंध 6/7  
पैरा 622

ANNEXURE 6/7  
PARA 622

उद्दिष्ट I

## ELEVATION I

1. DERRICK ERECTED.
2. GUY ROPE TIGHTENED WITH DEAD MAN
3. GIRDER PLACED IN THE BED AND SLING CONNECTED TO DERRICK AND GIRDER.

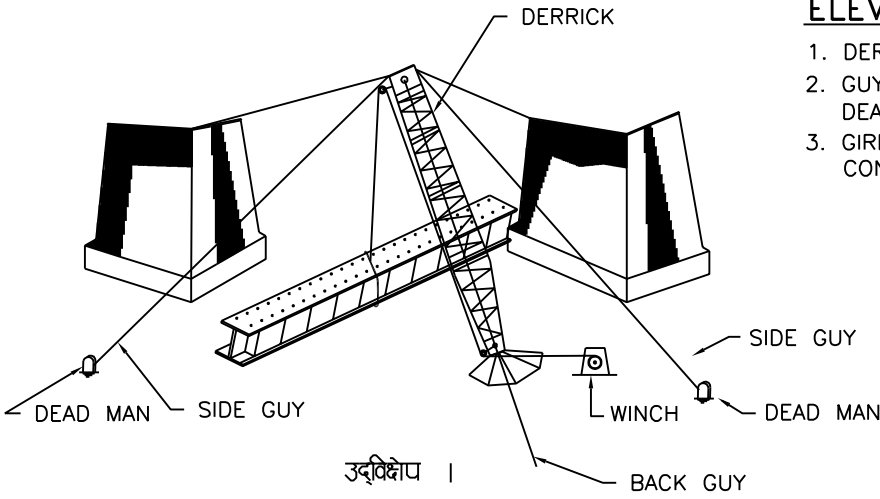

उद्दिष्ट I  
**ELEVATION I**

उद्दिष्ट II

## ELEVATION II

GIRDER LIFTED FROM BED AND ERECTED ON THE PIERS BY DERRICK.

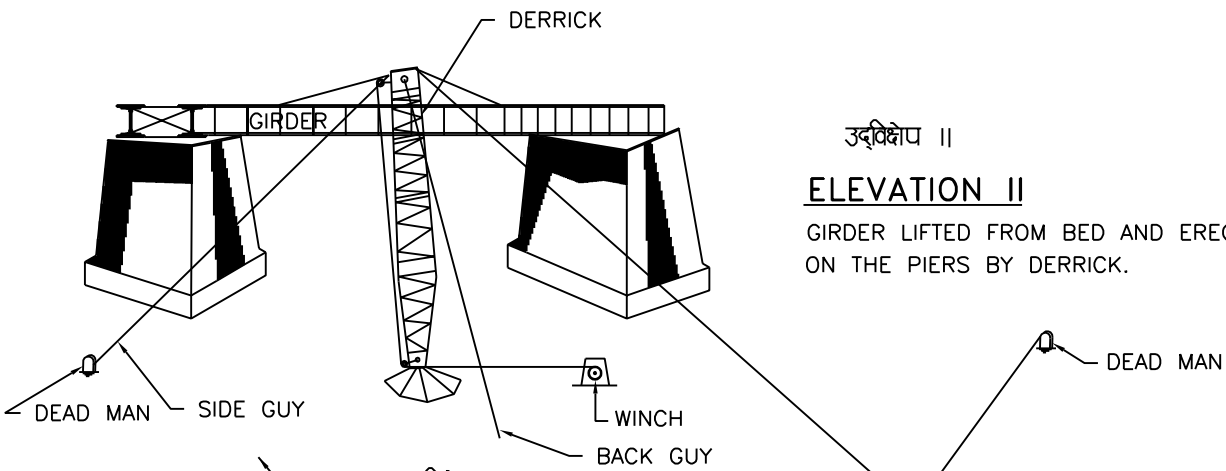

उद्दिष्ट II  
**ELEVATION II**

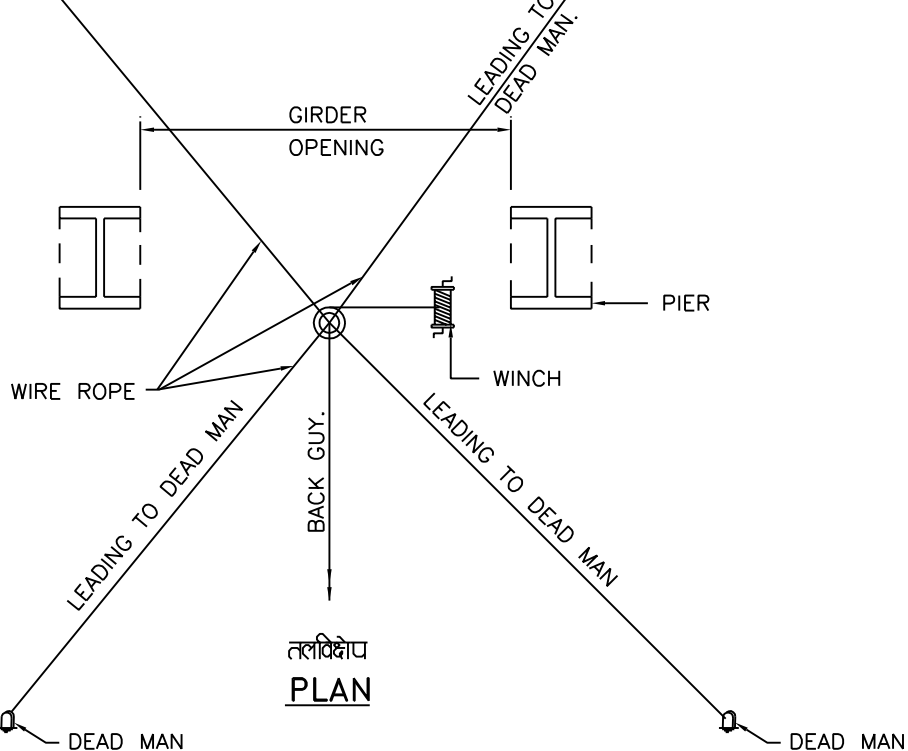

तलविष्ट  
**PLAN**

तार की रस्सी धराने वाली स्थिति  
डैड मैन को बंधे गाड़ज

**POSITION SHOWING WIRE ROPE  
GUYS TIGHTENED TO DEAD MAN**



(a) LAUNCHING OF 12.2m SPAN ON RAIL CLUSTERS BY SKIDDING PROCESS

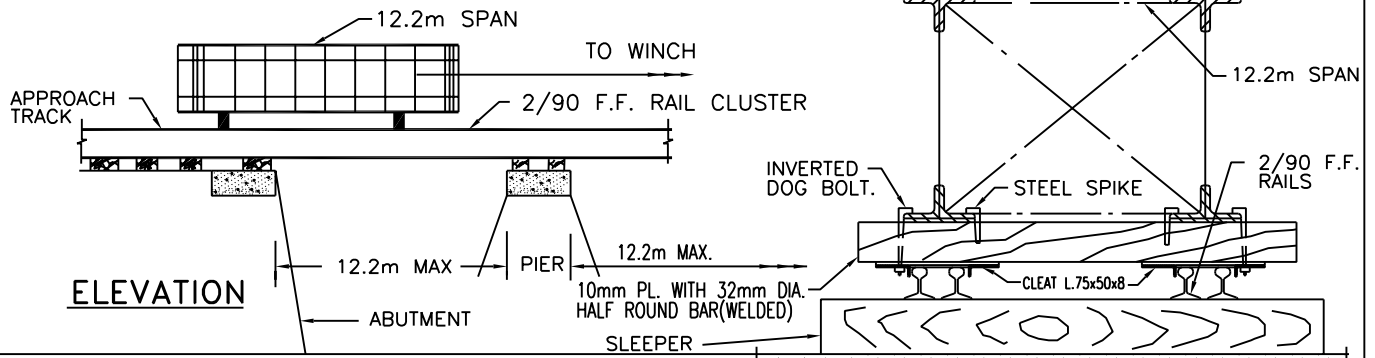

(b) LAUNCHING OF 12.2m SPAN ON RAIL CLUSTERS BY ROLLING WITH DIP TROLLIES

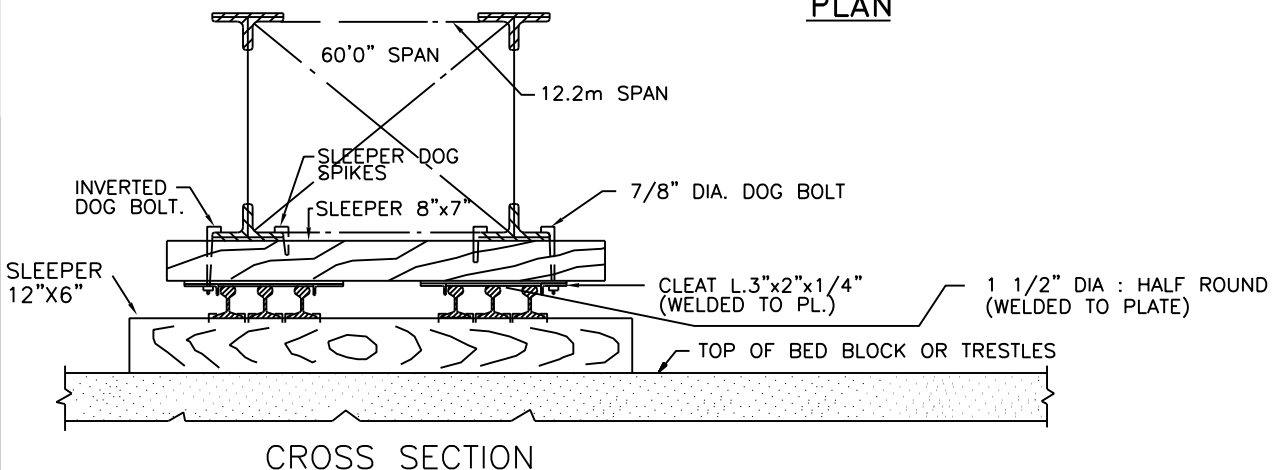
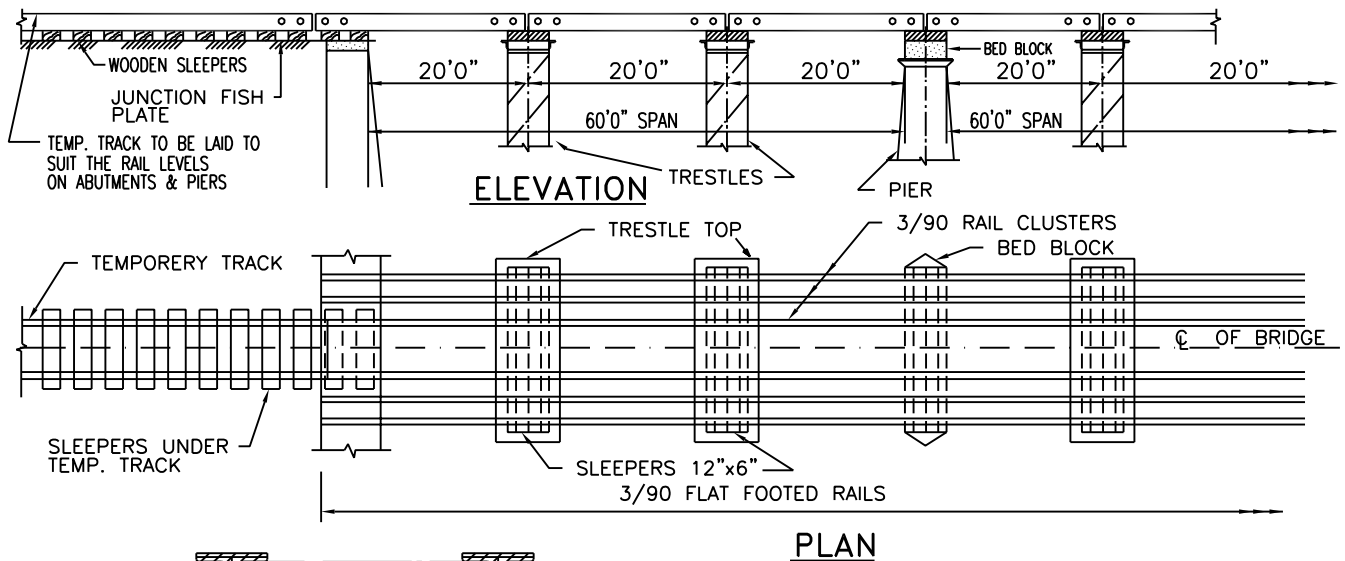
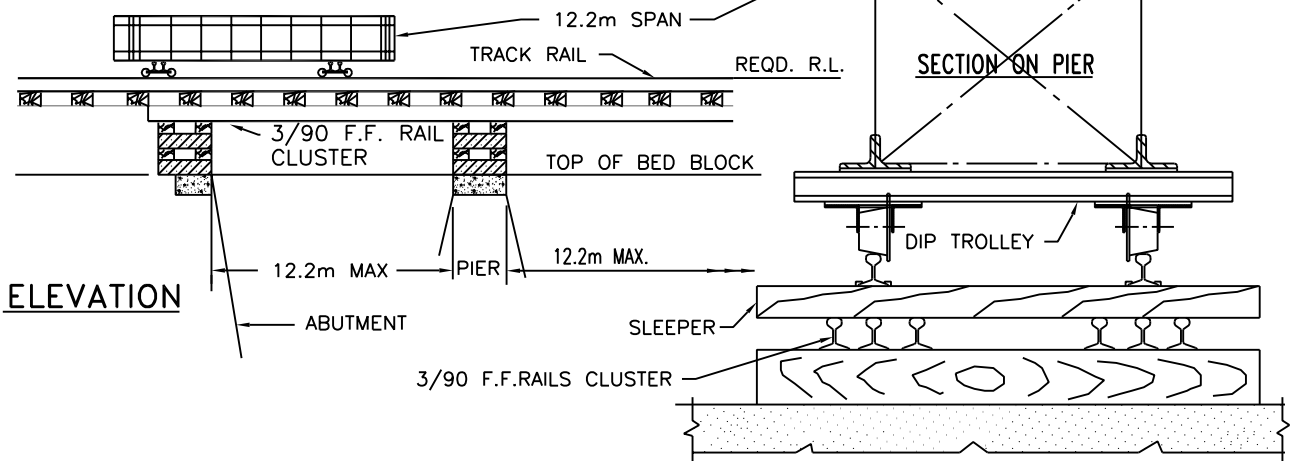

(c) LAUNCHING OF 18.3m SPANS WITH HELP OF RAIL CLUSTERS

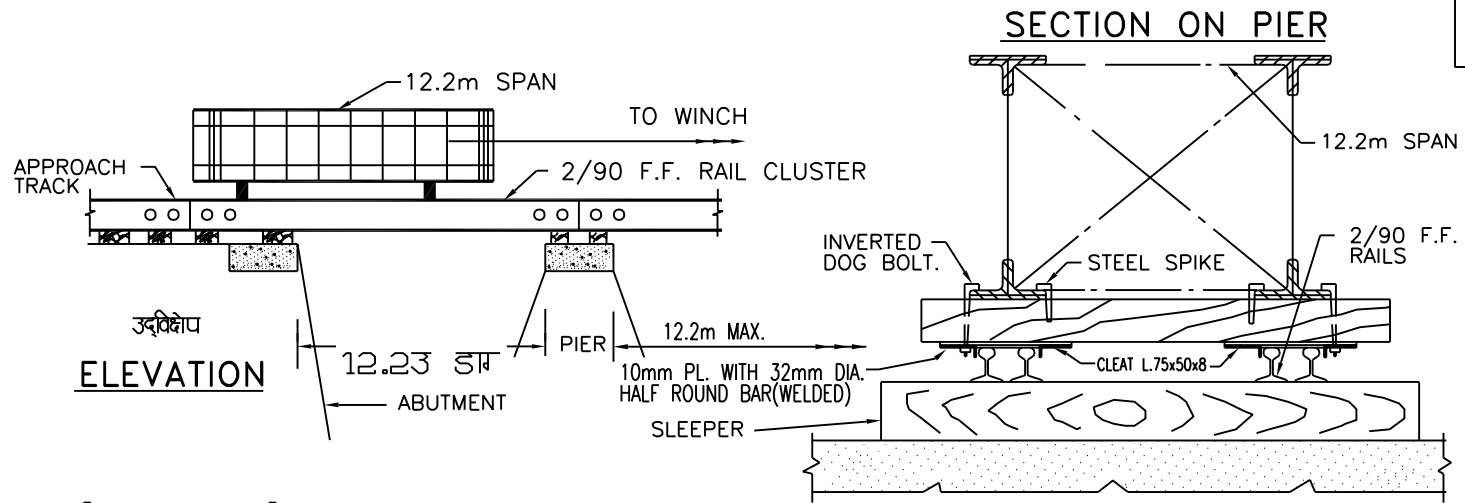

- (क) फिसलन प्रक्रिया द्वारा रेल क्लस्टरों पर 12.2 मी. स्पैन का प्रवर्तन
- (a) LAUNCHING OF 12.2m SPAN ON RAIL CLUSTERS BY SKIDDING PROCESS

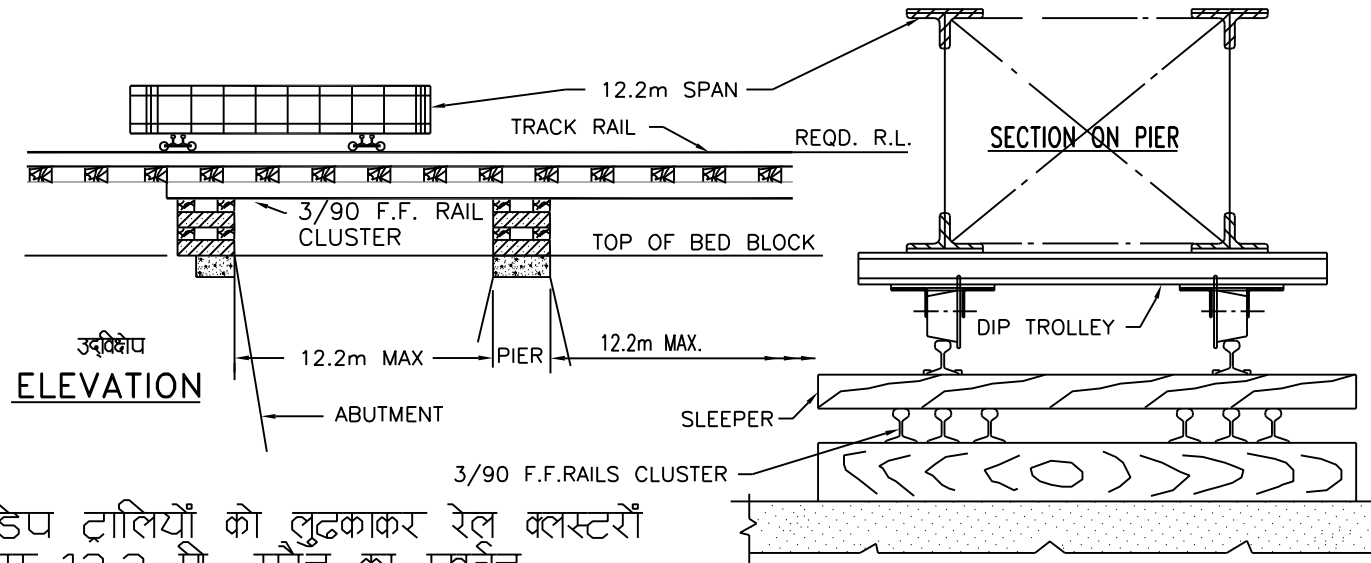

- (ख) डिप ट्रालियों को लुढ़काकर रेल क्लस्टरों पर 12.2 मी. स्पैन का प्रवर्तन
- (b) LAUNCHING OF 12.2m SPAN ON RAIL CLUSTERS BY ROLLING WITH DIP TROLRIES

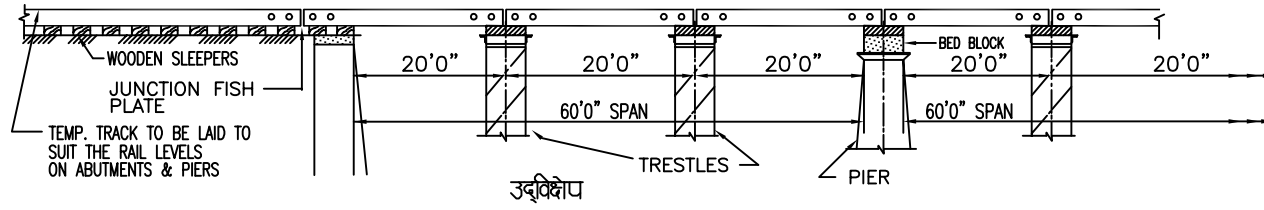

उदृष्टि  
**ELEVATION**

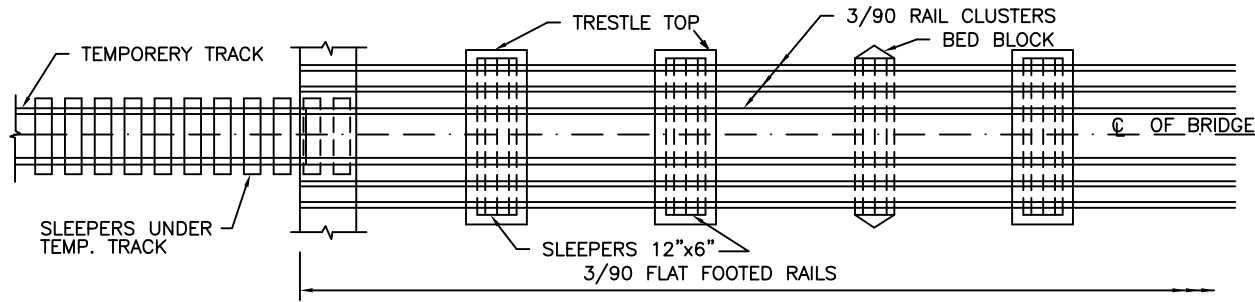

तलदृष्टि  
**PLAN**

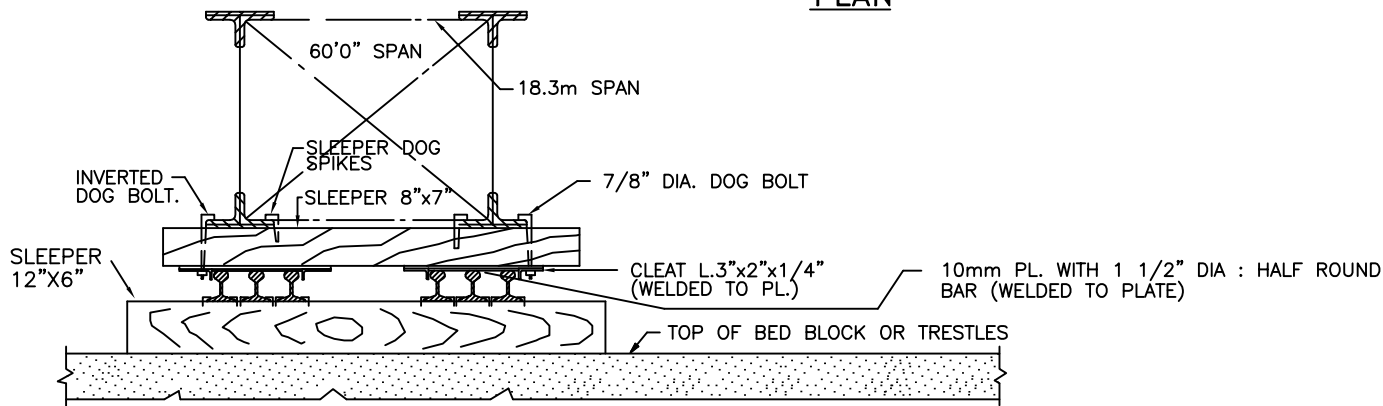

अनुदैर्घ्य काट  
**CROSS SECTION**

(ग) रेल सूमह के सहायता से 18.3 मी. स्पैनों का अंतरण

(C) LAUNCHING OF 18.3m SPANS WITH HELP OF RAIL CLUSTERS

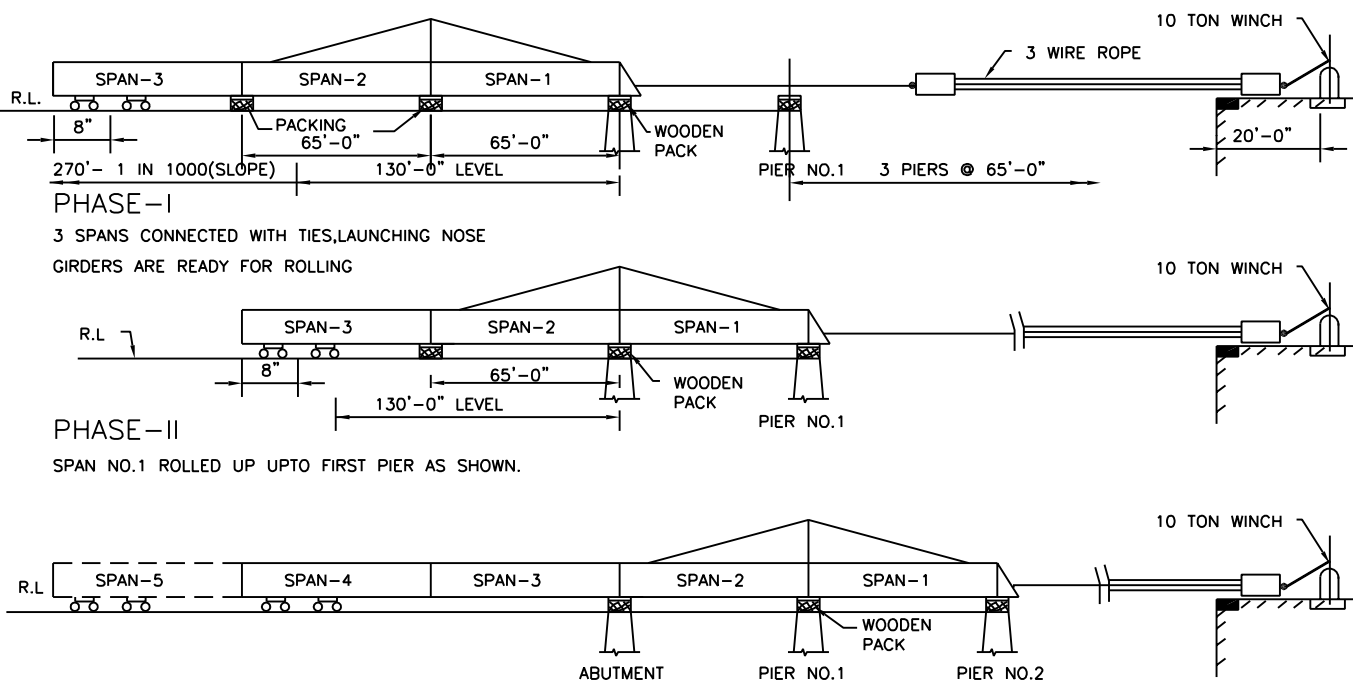
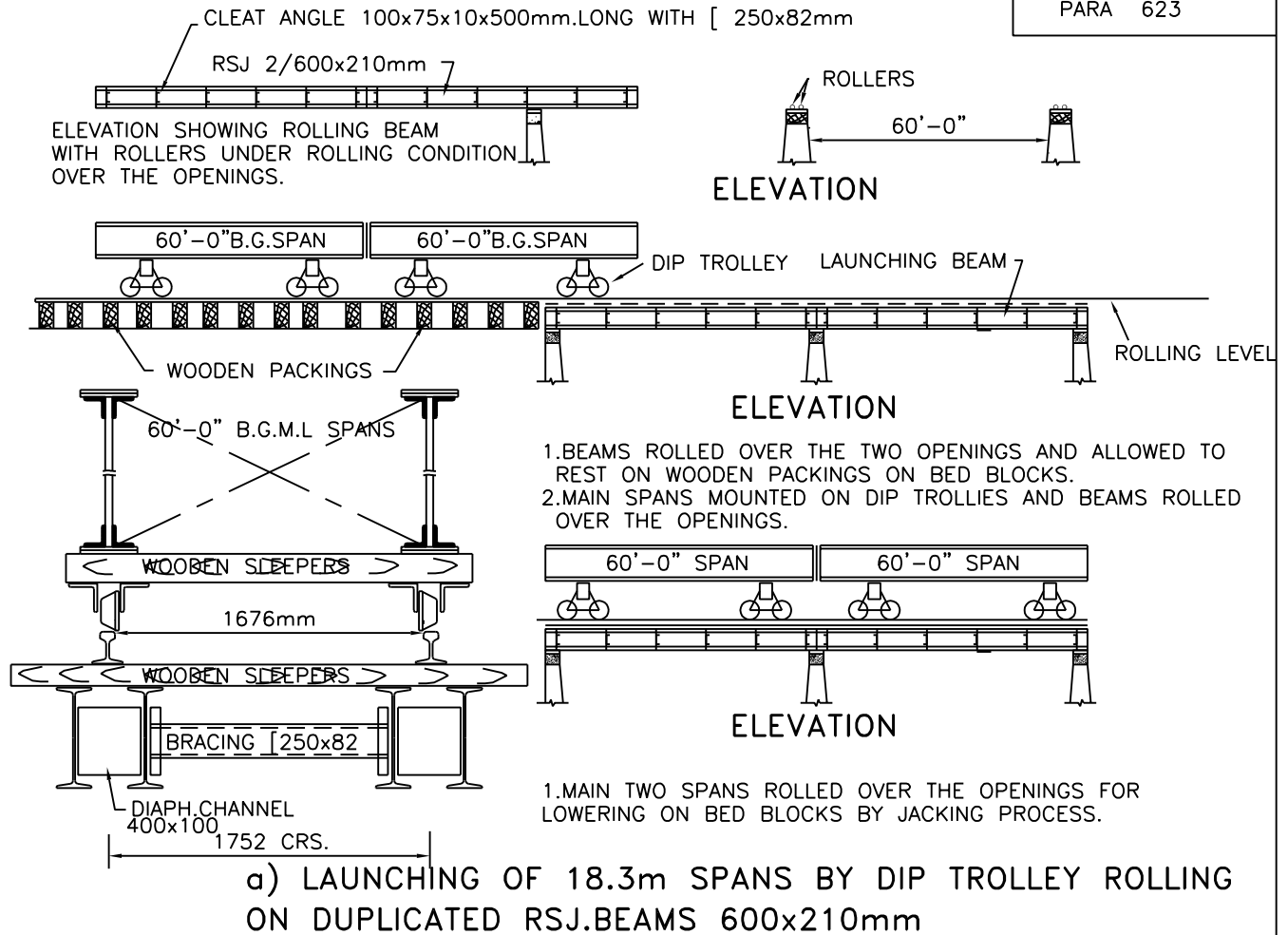



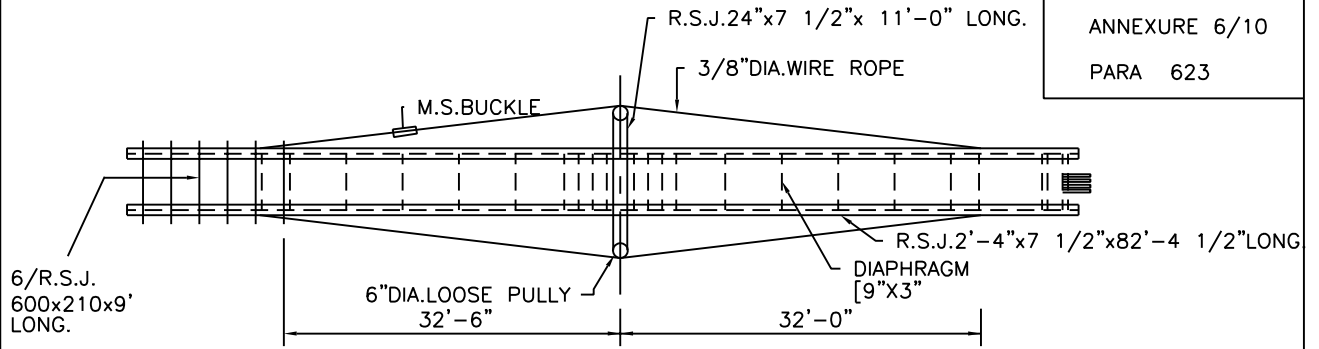

PLAN SHOWING THE POSITION OF WIRE ROPE FOR LATERAL STABILITY

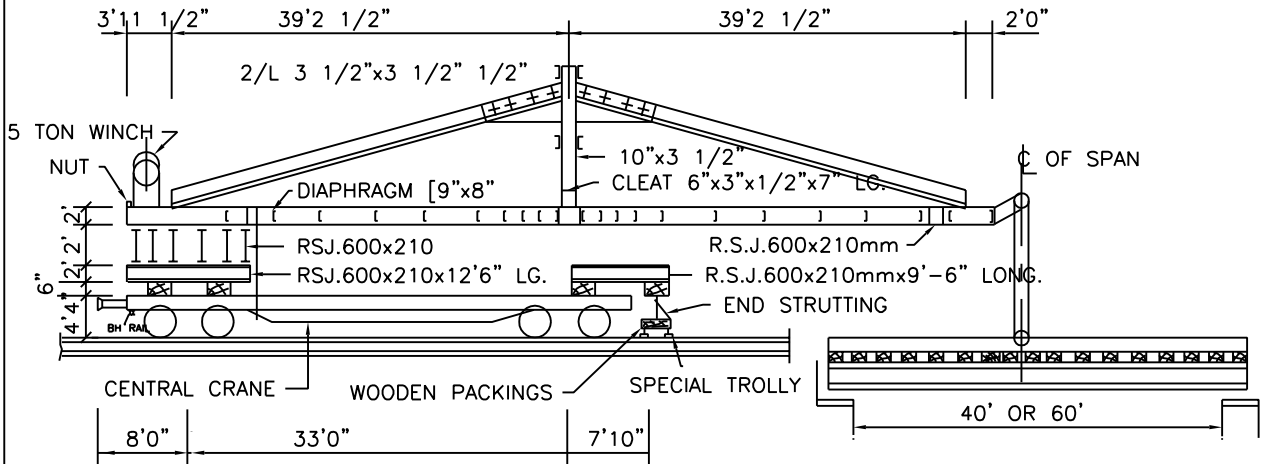

ELEVATION SHOWING THE SPAN LIFTED AND BEING LOWERED IN POSITION

a) LAUNCHING OF 12.2m & 18.3m SPANS WITH THE HELP OF BFR

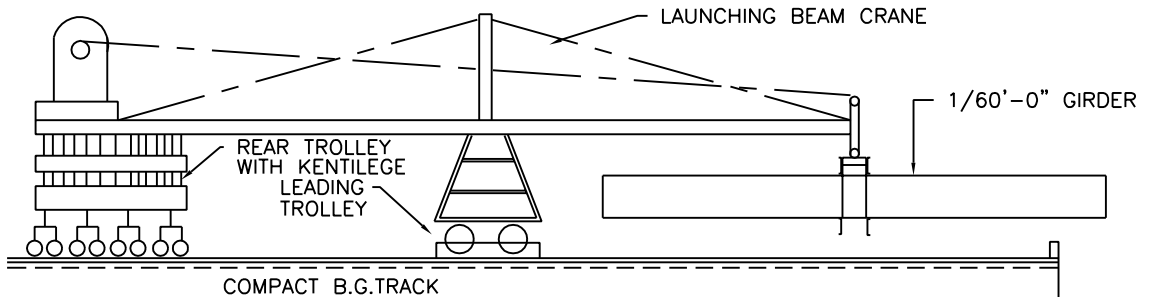

STAGE-1 - LAUNCHING BEAM CRANE ASSEMBLED ON APPROACHES  
 1/60' GIRDER LIFTED BY THE CRANE TO CLEAR OFF THE TRACK RAILS

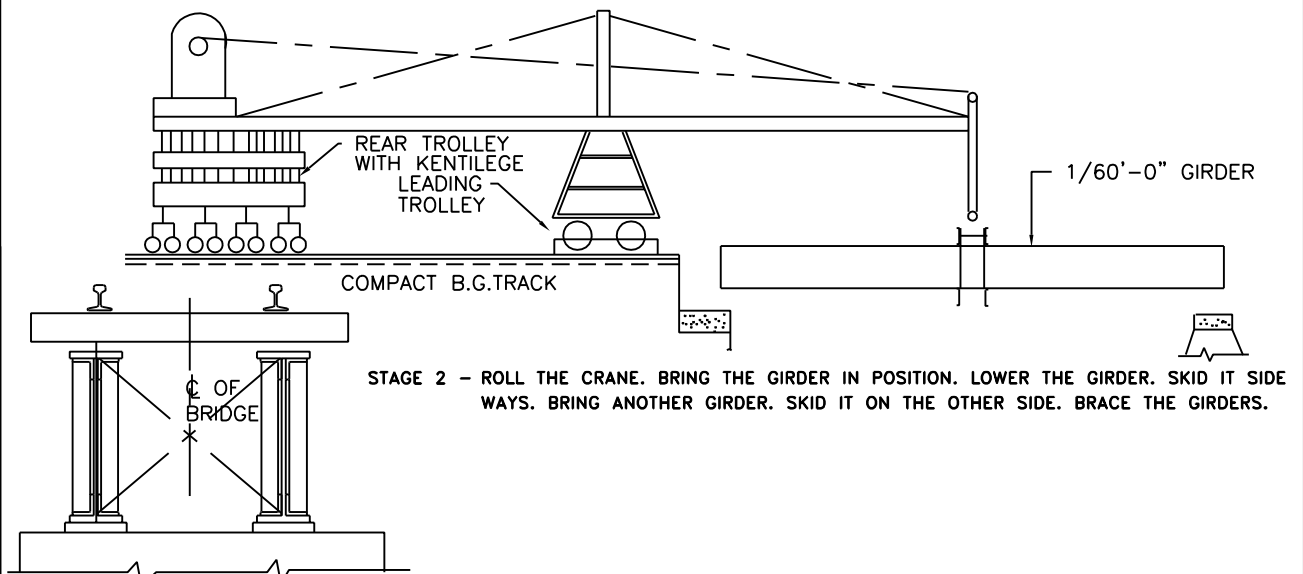

STAGE 2 - ROLL THE CRANE. BRING THE GIRDER IN POSITION. LOWER THE GIRDER. SKID IT SIDE WAYS. BRING ANOTHER GIRDER. SKID IT ON THE OTHER SIDE. BRACE THE GIRDERS.

b) ALTERNATIVE TO LAUNCHING PAD WITH B.F.R.METHOD

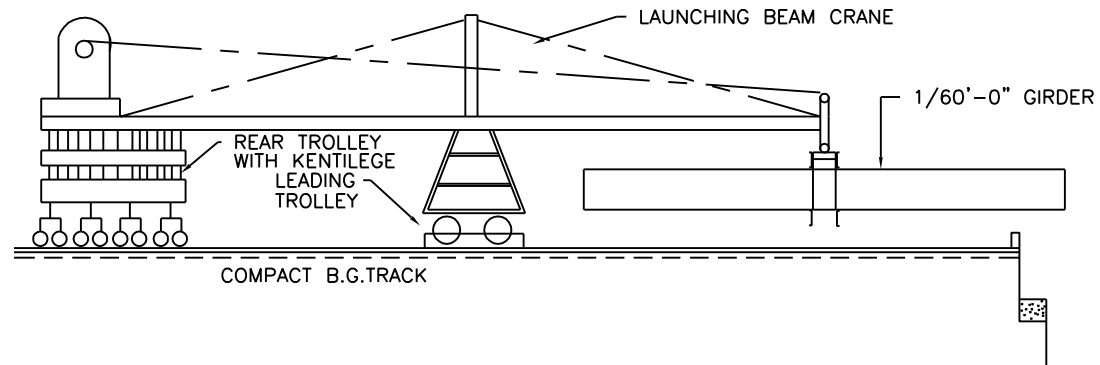

STAGE-1 - LAUNCHING BEAM CRANE ASSEMBLED ON APPROACHES  
1/60' GIRDER LIFTED BY THE CRANE TO CLEAR OFF THE TRACK RAILS

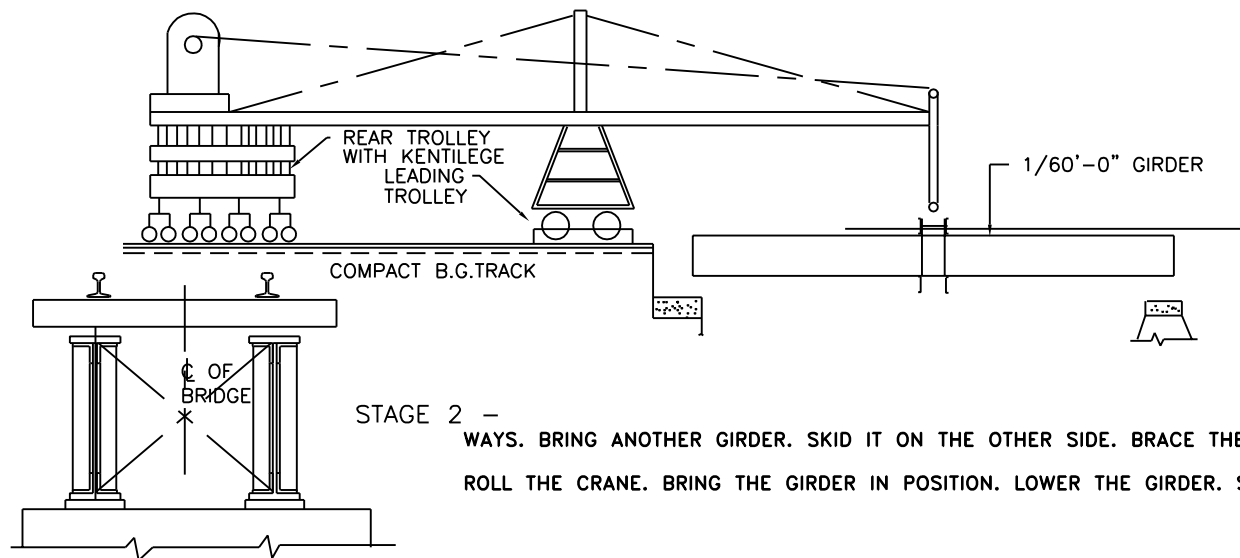

ख) बी एफ आर विधि से प्रवर्तन पैड का विकल्प

b) ALTERNATIVE TO LAUNCHING PAD WITH B.F.R.METHOD

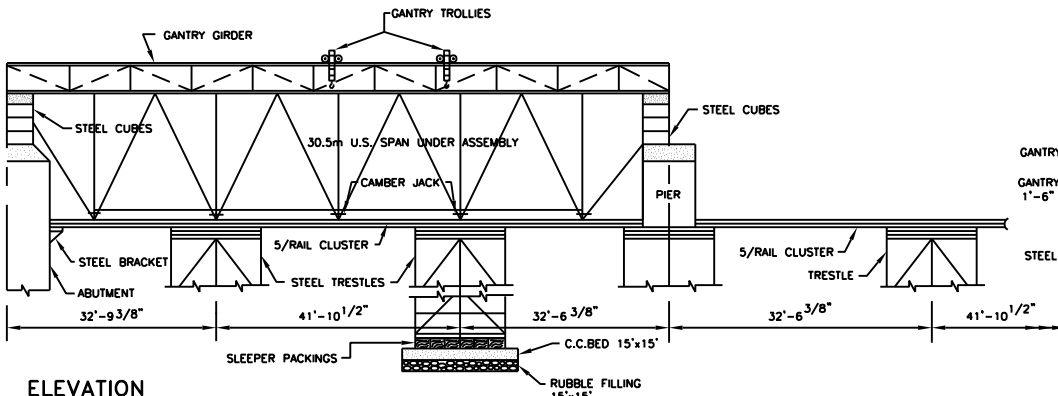

**ELEVATION**

1. STEEL TRETTLES, BRACKETS, CUBES, GENTRY GIRDERS & RAIL CLUSTERS IN POSITION
2. 100' U.S.SPAN UNDER ASSEMBLY

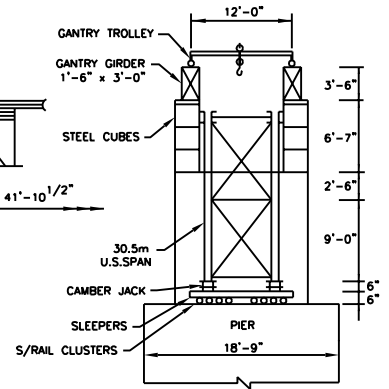

**CROSS SECTION ON PIER**

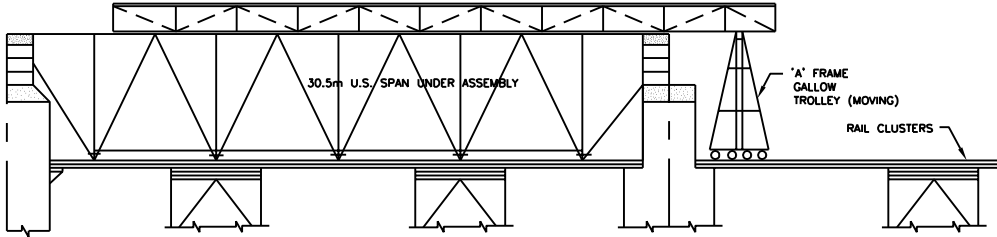

**ELEVATION**

1. 100' U.S. SPAN ASSEMBLED 100%
2. GALLOW TROLLEY ERECTED & GENTRY MOVED TO REST ON GALLOW TROLLEY
3. GENTRY GIRDERS MOVING OVER THE NEXT OPENING

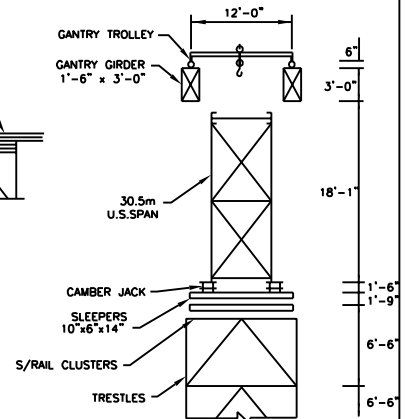

**CROSS SECTION ON PIER**

**(a) ERECTION & LAUNCHING BY TRESTLE METHOD**

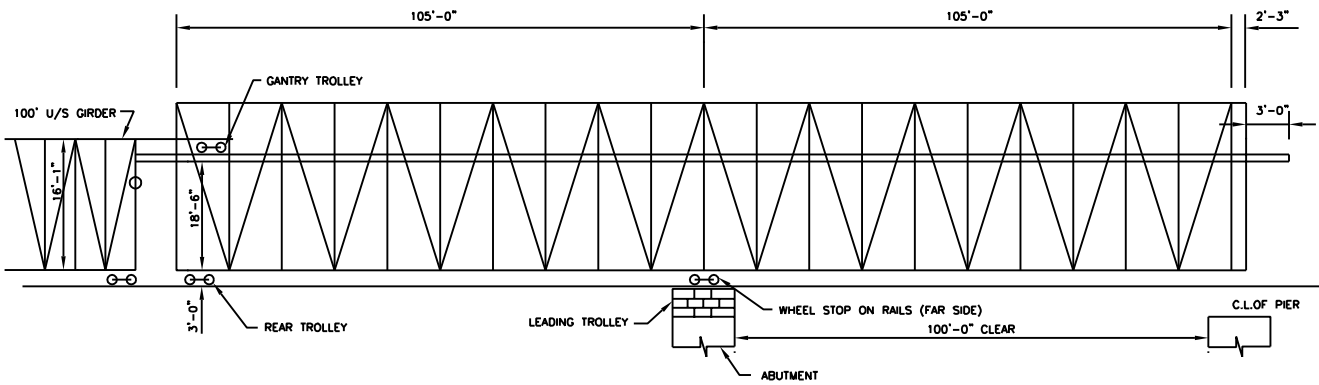

**PHASE II**

**PHASE-1**

SERVICE SPAN ERECTED ON APPROACHES ON BETUL END OF BRIDGE MOUNTED ON TROLLEYS AND LAUNCHED. NEW MAIN GIRDER BROUGHT NEAR THE SERVICE SPAN

**PHASE-11**

SERVICE SPAN PACKED ON THE 1st PIER AND ABUTMENT, LEADING TROLLEY SUPPORTED UNDER THE CENTRAL, VERTICAL REAR TROLLEY INSERTED UNDER THE 2nd VERTICAL FROM THE REAR END OF SPAN. NEW MAIN GIRDER ROLLED OVER THE GANTRIES, BROUGHT TO THE PROPER POSITION & READY FOR LOWERING.



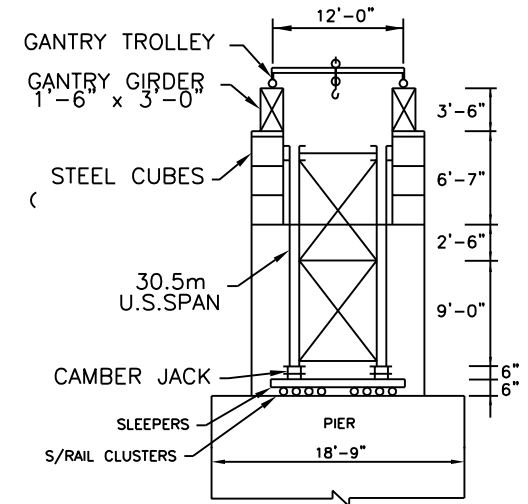
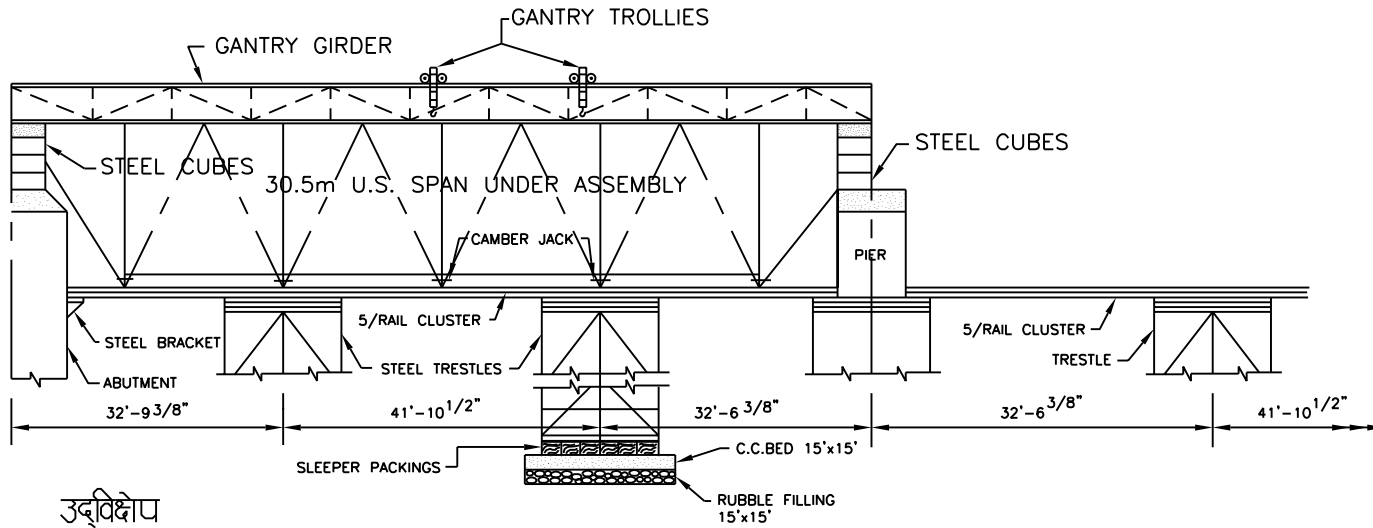

उद्विष्टोप  
**ELEVATION**

1. STEEL TRESTLES, BRACKETS, CUBES, GANTRY GIRDERS & RAIL CLUSTERS IN POSITION
2. 100' U.S.SPAN UNDER ASSEMBLY

पार पर अनुप्रस्थ काट  
**CROSS SECTION ON PIER**

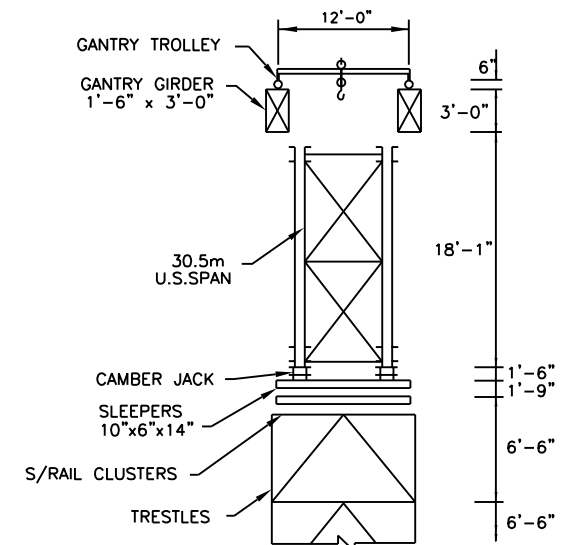
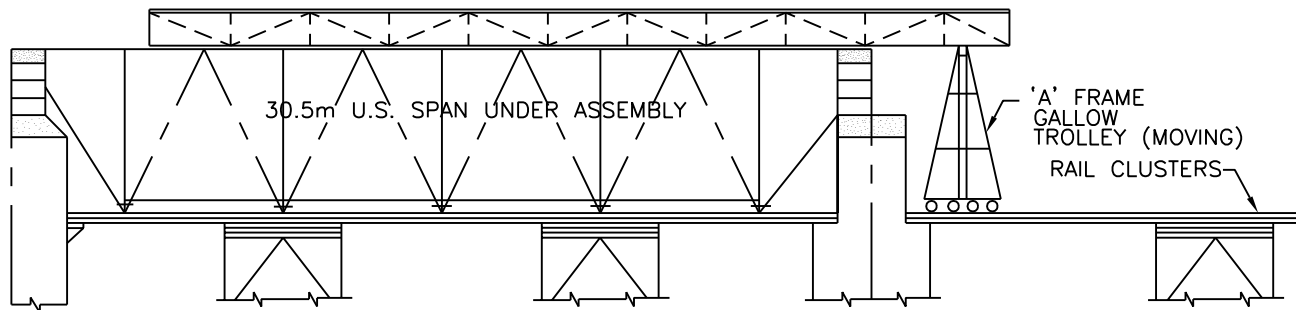

उद्विष्टोप  
**ELEVATION**

1. 100' U.S. SPAN ASSEMBLED 100%
2. GALLOW TROLLEY ERECTED & GANTRY MOVED TO REST ON GALLOW TROLLEY
3. GANTRY GIRDERS MOVING OVER THE NEXT OPENING

(क) ट्रेस्टल विधि द्वारा उत्थापन एवं प्रवर्तन

(a) ERECTION & LAUNCHING BY TRESTLE METHOD

ट्रेस्टल पर अनुप्रस्थ काट  
**CROSS SECTION ON TRESTLE**

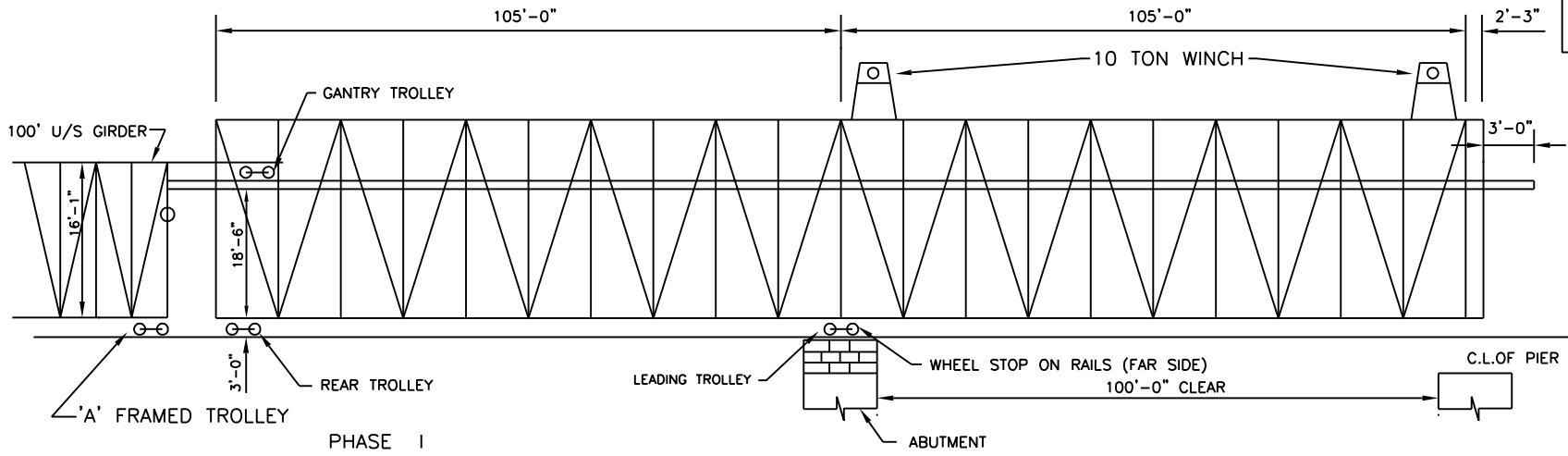

PHASE I

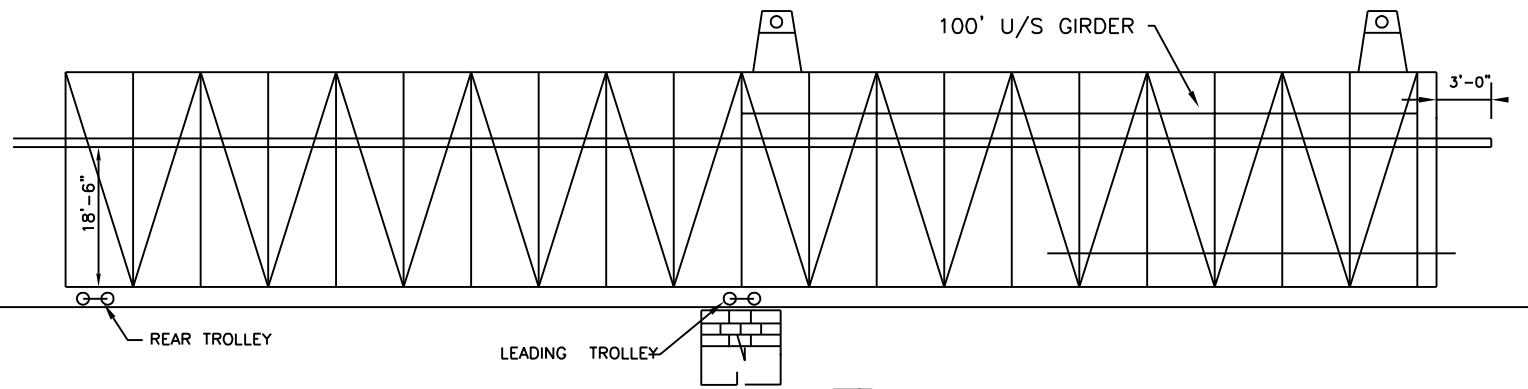

PHASE II

चरण - I  
PHASE-I

SERVICE SPAN ERECTED ON APPROACHES ON BETUL END OF BRIDGE MOUNTED ON TROLLIES AND LAUNCHED. NEW MAIN GIRDER BROUGHT NEAR THE SERVICE SPAN

चरण - II  
PHASE-II

SERVICE SPAN PACKED ON THE 1st PIER AND ABUTMENT, LEADING TROLLEY SUPPORTED UNDER THE CENTRAL, VERTICAL REAR TROLLEY INSERTED UNDER THE 2nd VERTICAL FROM THE REAR END OF SPAN. NEW MAIN GIRDER ROLLED OVER THE GANTRIES, BROUGHT TO THE PROPER POSITION & READY FOR LOWERING.

(ख) सर्विस स्पैन सहित गर्डर का प्रवर्तन

(b) LAUNCHING OF GIRDER WITH SERVICE SPAN

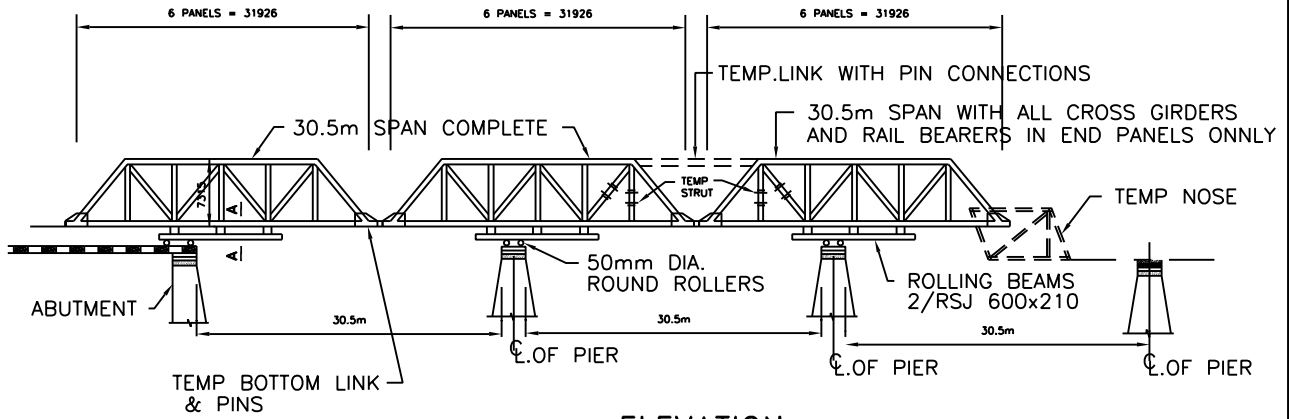

**ELEVATION**

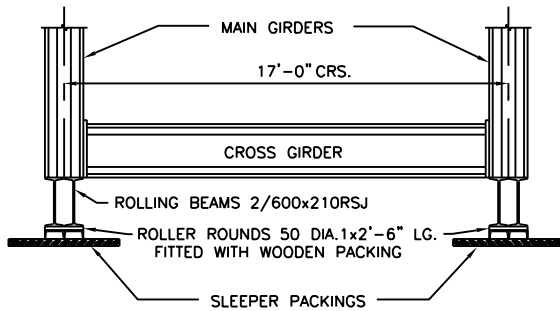

**CROSS SECTION A-A**

**LINKING AND ROLLING PROCESS  
FOR LAUNCHING OF MULTIPLE  
30.5m SPANS**

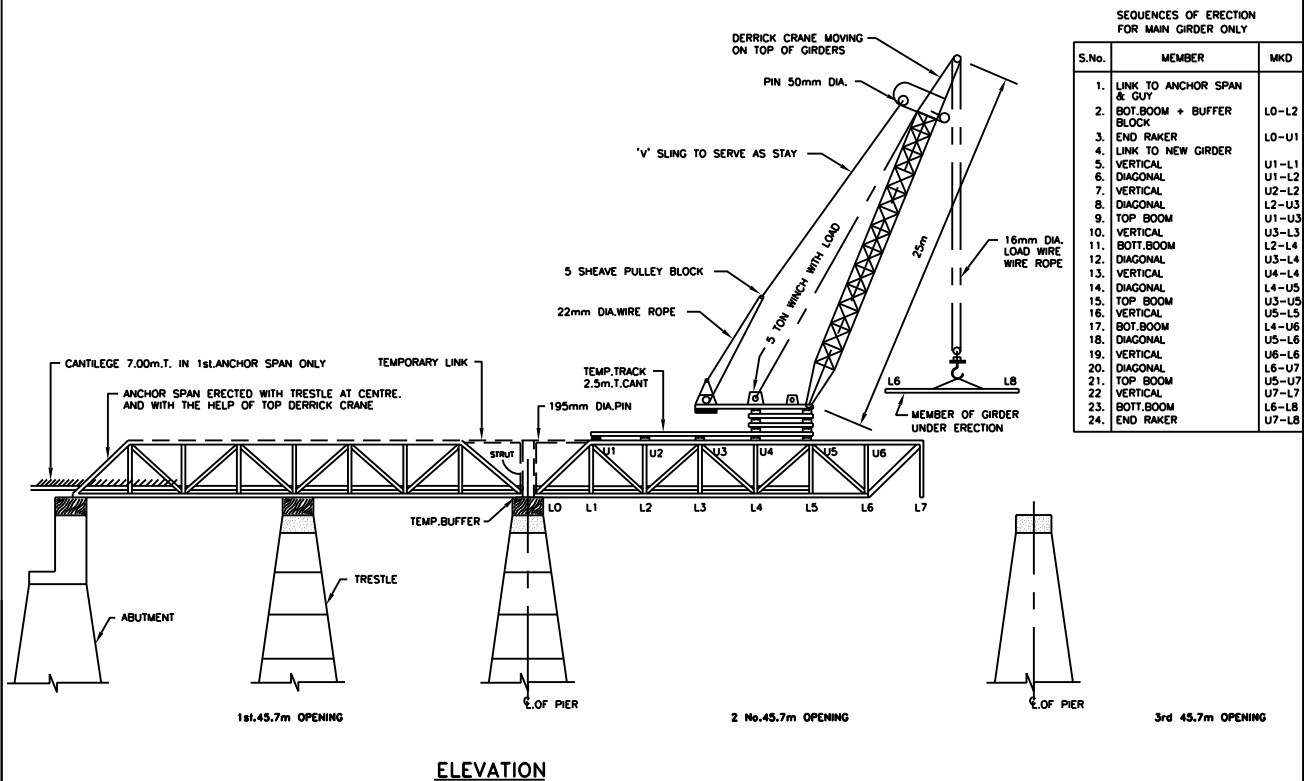

SEQUENCES OF ERECTION  
FOR MAIN GIRDER ONLY

S.No.	MEMBER	MKD
1.	LINK TO ANCHOR SPAN & GUY BLOCK	L0-L2
2.	BOT. BOOM + BUFFER	L0-L2
3.	END RAKER	L0-U1
4.	LINK TO NEW GIRDER	
5.	VERTICAL	U1-L1
6.	DIAGONAL	U1-L2
7.	VERTICAL	U2-L2
8.	DIAGONAL	L2-L3
9.	TOP BOOM	U1-U3
10.	VERTICAL	U3-L3
11.	BOTT. BOOM	L2-L4
12.	DIAGONAL	U3-L4
13.	VERTICAL	U4-L4
14.	DIAGONAL	L4-U5
15.	TOP BOOM	U3-U5
16.	VERTICAL	U5-L5
17.	BOTT. BOOM	L4-U6
18.	DIAGONAL	U5-L6
19.	VERTICAL	U6-L6
20.	DIAGONAL	L6-U7
21.	TOP BOOM	U5-U7
22.	VERTICAL	U7-L7
23.	BOTT. BOOM	L6-L8
24.	END RAKER	U7-L8

**ELEVATION**

**(b) ERECTION AND LAUNCHING  
PROCESS FOR MULTIPLE 45.7m  
SPANS WITH THE HELP OF DERRICK  
CRANE "GAJRAJ"**

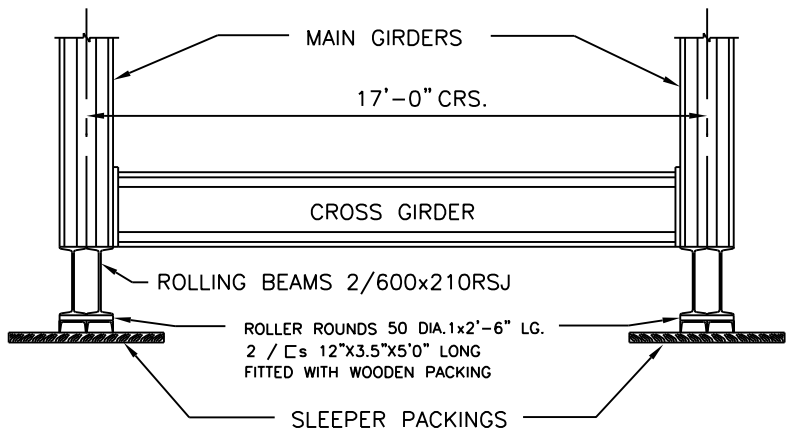
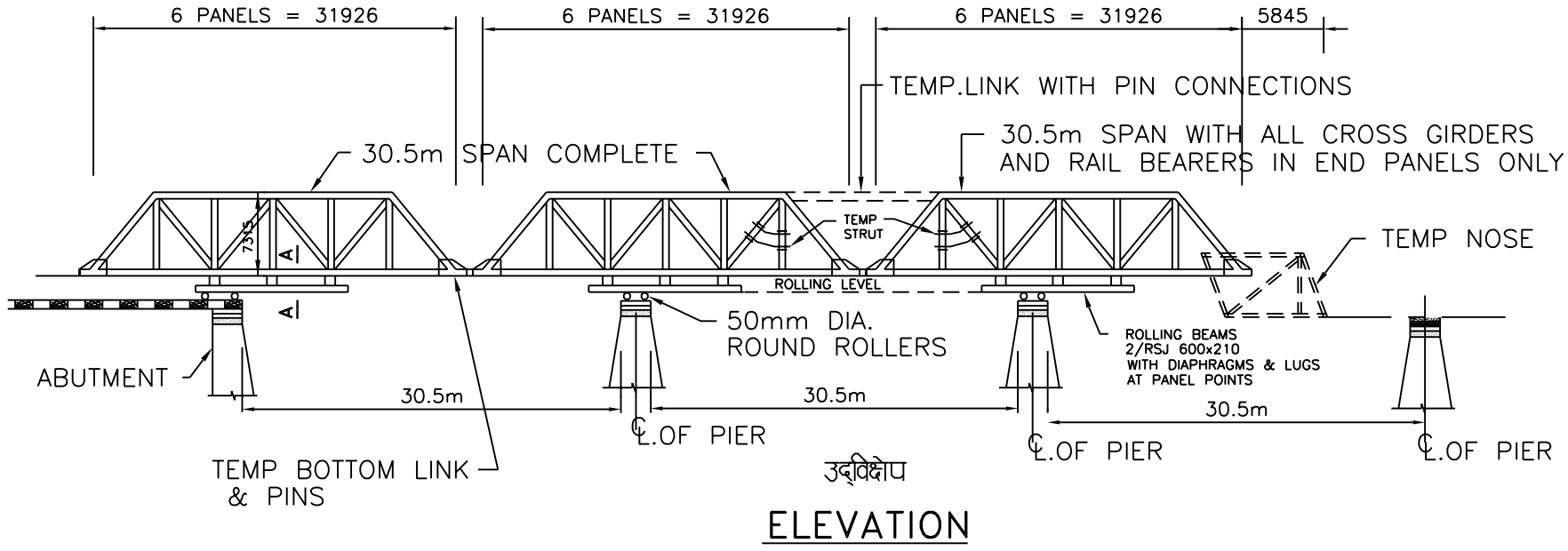

अनुप्रस्थ काट A-A  
CROSS SECTION A-A

(क) बहुविध 30.5 मी. स्पैनों के प्रवर्तन की जोड़न एवं चल प्रक्रिया

(a) LINKING AND ROLLING PROCESS FOR LAUNCHING OF MULTIPLE 30.5m SPANS

SEQUENCES OF ERECTION FOR MAIN GIRDER ONLY

S.No.	MEMBER	MKD
1.	LINK TO ANCHOR SPAN & GUY	
2.	BOT. BOOM + BUFFER BLOCK	L0-L2
3.	END RAKER	L0-U1
4.	LINK TO NEW GIRDER	—
5.	VERTICAL	U1-L1
6.	DIAGONAL	U1-L2
7.	VERTICAL	U2-L2
8.	DIAGONAL	L2-U3
9.	TOP BOOM	U1-U3
10.	VERTICAL	U3-L3
11.	BOTT. BOOM	L2-L4
12.	DIAGONAL	U3-L4
13.	VERTICAL	U4-L4
14.	DIAGONAL	L4-U5
15.	TOP BOOM	U3-U5
16.	VERTICAL	U5-L5
17.	BOTT. BOOM	L4-U6
18.	DIAGONAL	U5-L6
19.	VERTICAL	U6-L6
20.	DIAGONAL	L6-U7
21.	TOP BOOM	U5-U7
22.	VERTICAL	U7-L7
23.	BOTT. BOOM	L6-L8
24.	END RAKER	U7-L8

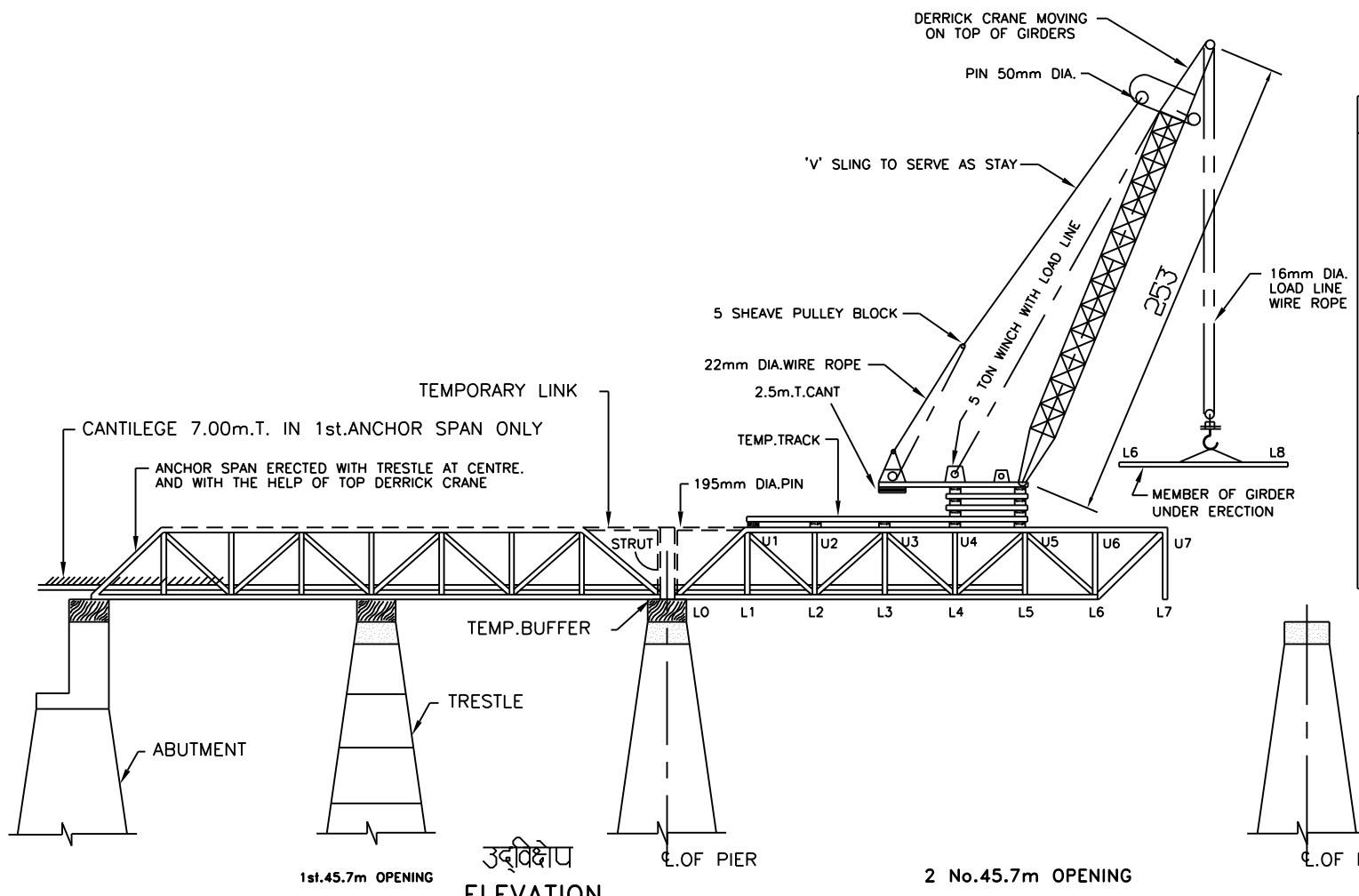

उद्दिष्ट  
**ELEVATION**

(ख) डेरिक्रेन "गजराज" की सहायता से बहुविध 45.7 मी. स्पैनों के लिए उत्थापन तथा प्रवर्तन प्रक्रिया

2 No. 45.7m OPENING 3rd 45.7m OPENING

(b) ERECTION AND LAUNCHING PROCESS FOR MULTIPLE 45.7m SPANS WITH THE HELP OF DERRICK CRANE "GAJRAJ"

**Annexure - 7/1**

**Para - 711.2**

**MEASUREMENTS DURING MONSOON**

Gauge and afflux records of river : \_\_\_\_\_

Bridge Number : \_\_\_\_\_

For the Year : \_\_\_\_\_

Kilometerage of Bridge /Location : \_\_\_\_\_

Rail Level : \_\_\_\_\_

Highest Flood Level recorded so far : \_\_\_\_\_

Sr. No.	Date	Time	Up Stream	Down Stream	Afflux (Col 4-5)	Flood Slope	Velocity of Flow	Signature
1	2	3	4	5	6	7	8	9

FROM ATARI RAIL LEVEL 242.58  
 BOTTOM OF GIRDERS 241.28  
 TOP OF PIERS 240.19

TO LUDHIANA

अनुबंध 7/2 ANNEXURE 7/2  
 पैरा 711.3 & 712.1 PARA - 711.3 & 712.1

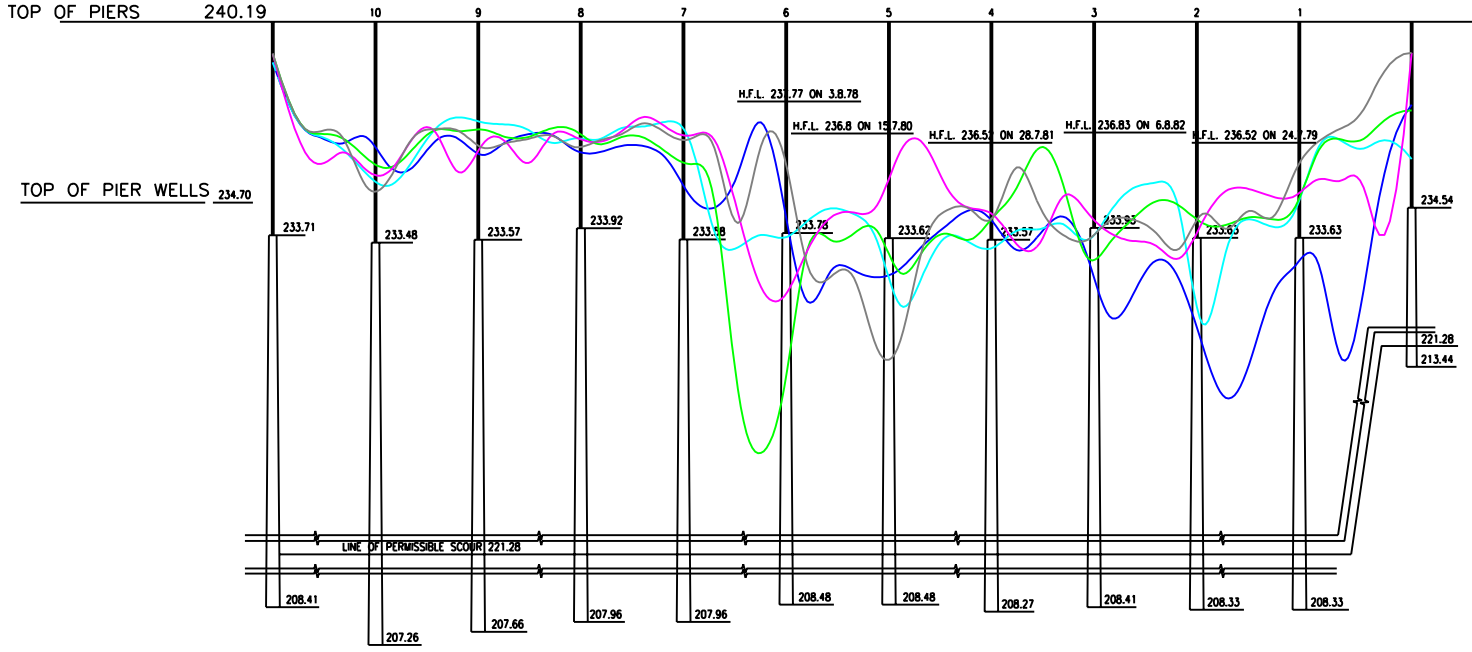

H.W.L. 237.77 ON 3.8.78 SHOWN THUS  
 H.W.L. 236.52 ON 24.7.79 SHOWN THUS  
 H.W.L. 236.80 ON 15.7.80 SHOWN THUS  
 H.W.L. 236.52 ON 28.7.81 SHOWN THUS  
 H.W.L. 236.83 ON 6.8.82 SHOWN THUS

FOR THE YEAR 1978	239.23	236.79	236.79	236.79	237.14	234.73	235.19	236.95	236.90	237.05	236.16	236.56	236.59	236.90	236.19	236.65	236.68	237.32	237.32	236.46	237.29	232.47	238.93	240.59	231.90	232.42	233.08	239.68	239.65	234.03	234.51	234.73	233.54	236.71	233.72	234.33	233.93	232.71	235.02	233.37	234.91	235.93	236.62	236.98	237.27	239.25	239.25		
FOR THE YEAR 1979	239.22	236.74	236.74	236.74	235.43	235.56	235.38	236.78	237.32	234.91	236.75	236.80	235.37	237.13	236.65	236.45	236.80	237.32	237.32	236.60	237.15	234.39	238.93	240.59	231.90	232.42	233.08	239.68	239.65	234.03	234.51	234.73	233.54	236.71	233.72	234.33	233.93	232.71	235.02	233.37	234.91	235.93	236.62	236.98	237.27	239.25	239.25		
FOR THE YEAR 1980	239.22	236.83	236.78	236.78	235.02	235.56	235.30	236.78	237.09	236.77	237.03	236.63	235.37	237.03	236.33	237.00	236.27	236.78	237.09	236.46	236.72	236.17	237.88	238.93	240.59	231.90	232.42	233.08	239.68	239.65	234.03	234.51	234.73	233.54	236.71	233.72	234.33	233.93	232.71	235.02	233.37	234.91	235.93	236.62	236.98	237.27	239.25	239.25	
FOR THE YEAR 1981	238.96	236.84	236.77	236.78	235.55	235.56	235.92	236.30	236.78	237.09	236.77	237.03	236.63	237.09	236.33	237.03	236.78	237.09	236.46	236.72	236.17	237.24	236.17	237.88	238.93	240.59	231.90	232.42	233.08	239.68	239.65	234.03	234.51	234.73	233.54	236.71	233.72	234.33	233.93	232.71	235.02	233.37	234.91	235.93	236.62	236.98	237.27	239.25	239.25
FOR THE YEAR 1982	238.96	236.84	236.77	236.78	235.55	235.56	235.92	236.30	236.78	237.09	236.77	237.03	236.63	237.09	236.33	237.03	236.78	237.09	236.46	236.72	236.17	237.24	236.17	237.88	238.93	240.59	231.90	232.42	233.08	239.68	239.65	234.03	234.51	234.73	233.54	236.71	233.72	234.33	233.93	232.71	235.02	233.37	234.91	235.93	236.62	236.98	237.27	239.25	239.25

लुधियाना-अटारी खंड पर पुल संख्या 5A पर 1978 से 1982 के लिए 30.0 मी. डाउन स्ट्रीम पर बाढ़ के बाद नदि के पाट के क्रॉस सेक्शन

CROSS SECTIONS OF RIVER BED AFTER FLOODS ON 30.0 m DN. STREAM SIDE FOR THE YEAR 1978 TO 1982 AT BRIDGE No. 5A ON LDH-ATT SECTION

(LEVELS SHOWN IN METRES)

**REFERENCE**  
 1 RIVER COURSE AFTER MONSOON 1971 SHOWN THUS ———  
 2 RIVER COURSE AFTER MONSOON 1972 SHOWN THUS - - - - -  
 3 RIVER COURSE AFTER MONSOON 1973 SHOWN THUS - - - - -

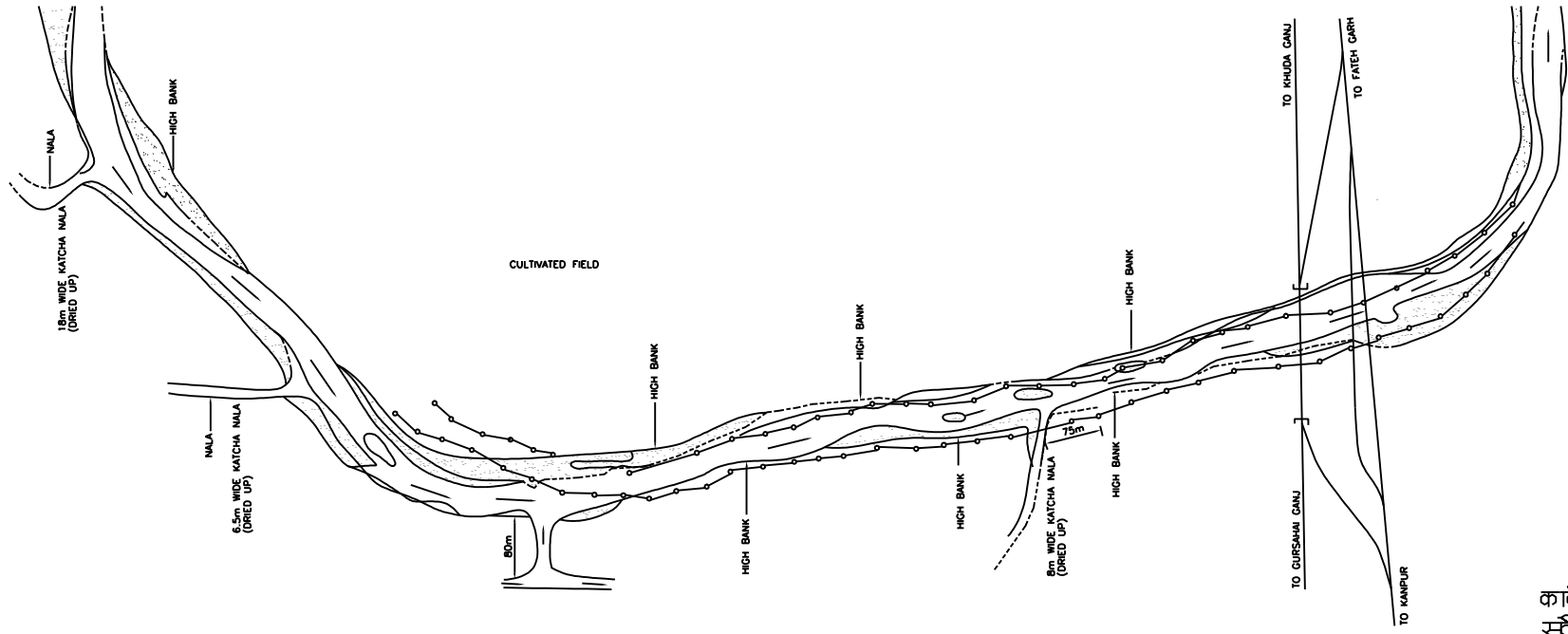

काली नदी की  
 सर्वेक्षण योजना  
**SURVEY PLAN OF  
 KALI NADI**  
 BRIDGE No. 143 (9x18.3m  
 GIRDER) AT Km 109/1-110/1



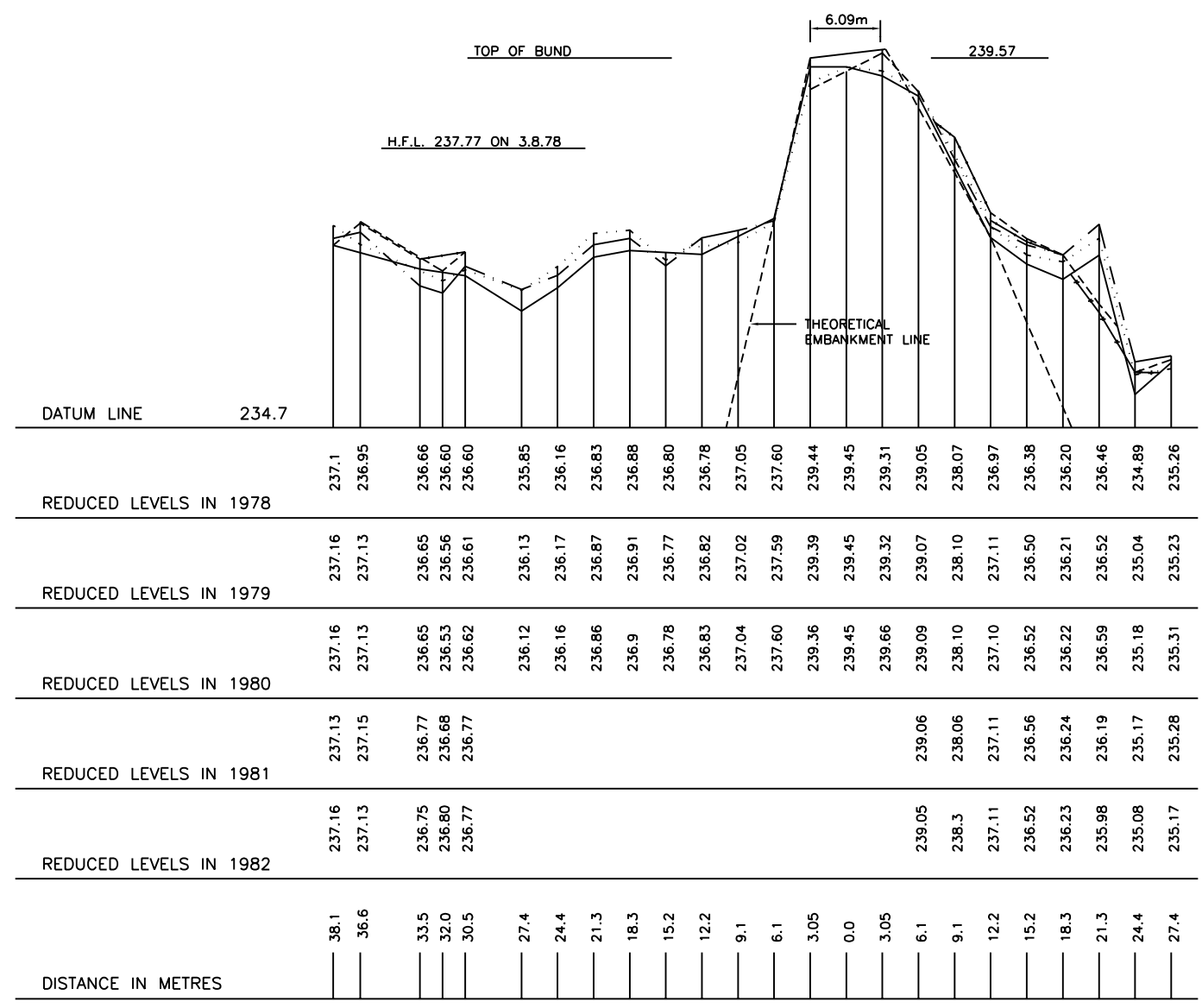

NOTE:

1. SECTIONS TAKEN IN DEC 1978 SHOWN IN \_\_\_\_\_
2. SECTIONS TAKEN IN DEC 1979 SHOWN IN .....
3. SECTIONS TAKEN IN DEC 1980 SHOWN IN - - - - -
4. SECTIONS TAKEN IN DEC 1981 SHOWN IN - - - - -
5. SECTIONS TAKEN IN DEC 1982 SHOWN IN \* - - - - \*

सतलज नदी (फिल्लौर के निकट)  
 व (i) उत्तरी बेल बंड  
RIVER SUTLEJ (NEAR PHILLAUR)  
F (i) NORTH BELL BUND

(LEVELS SHOWN IN METRES)



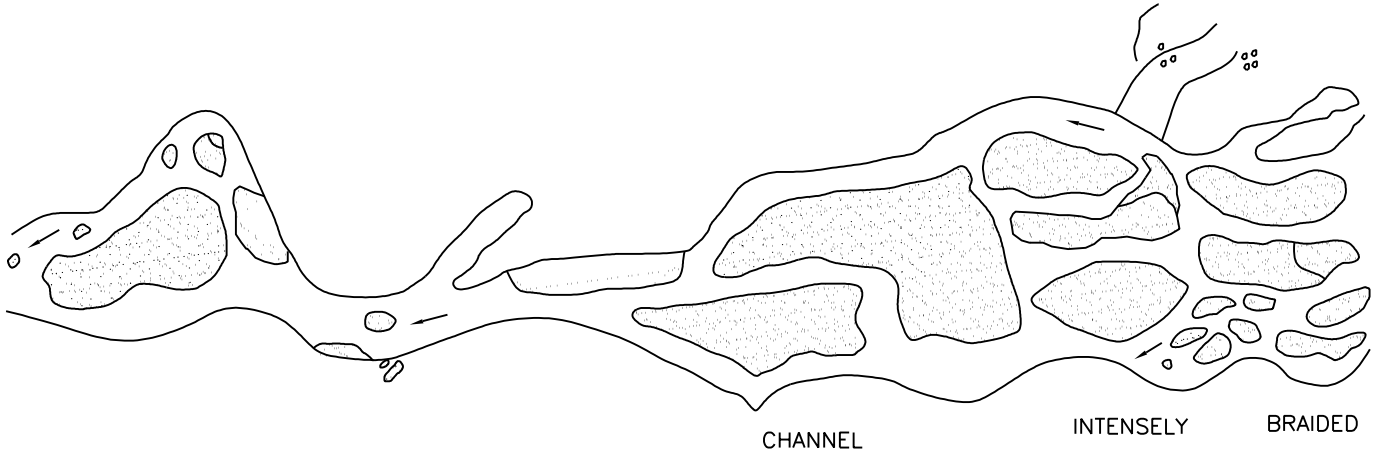

ब्रेडिंग पद्धति को दर्शाने वाली एक नदी

A RIVER SHOWING BRAIDING PATTERN

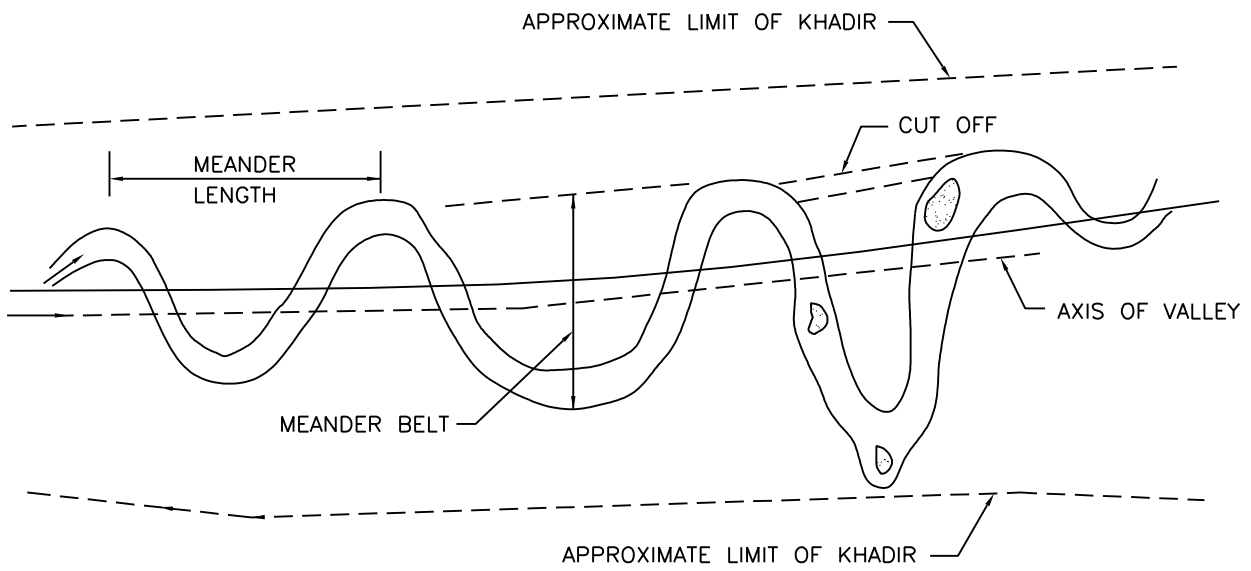

जलोढ खंडों में भटकव पध्दति

MEANDER PATTERN IN ALLUVIAL REACHES

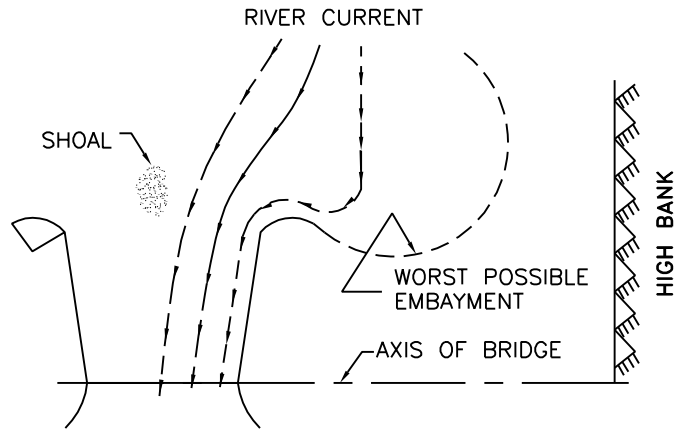

1. अपस्ट्रीम को मोड़ने वाला  
**1 DIVERGENT UPSTREAM**

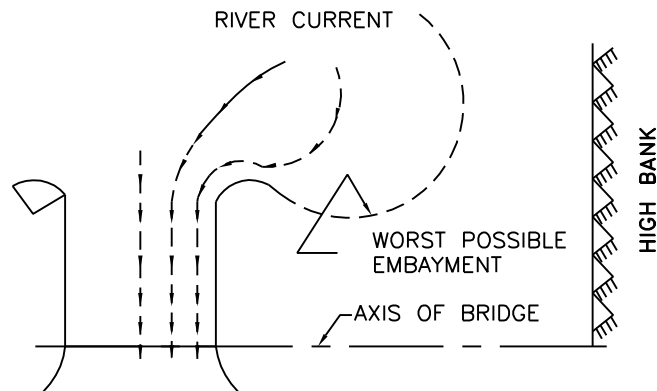

2. समान्तर  
**2 PARALLEL**

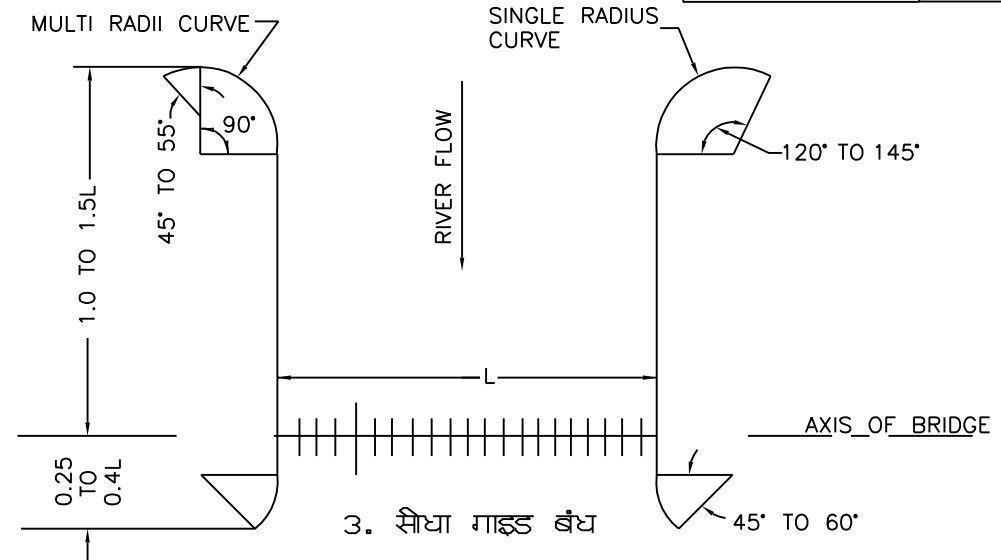

3. सीधा गाइड बंध  
**3 STRAIGHT GUIDE BUND**

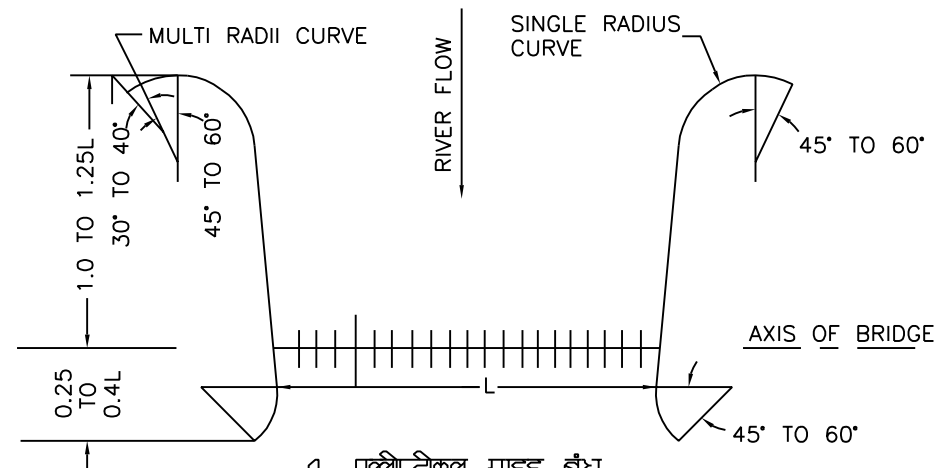

4. एल्लिप्टिकल गाइड बंध  
**4 ELLIPTICAL GUIDE BUND**

गाइड बंधों के विभिन्न आकार  
**DIFFERENT FORMS OF GUIDE BUND**

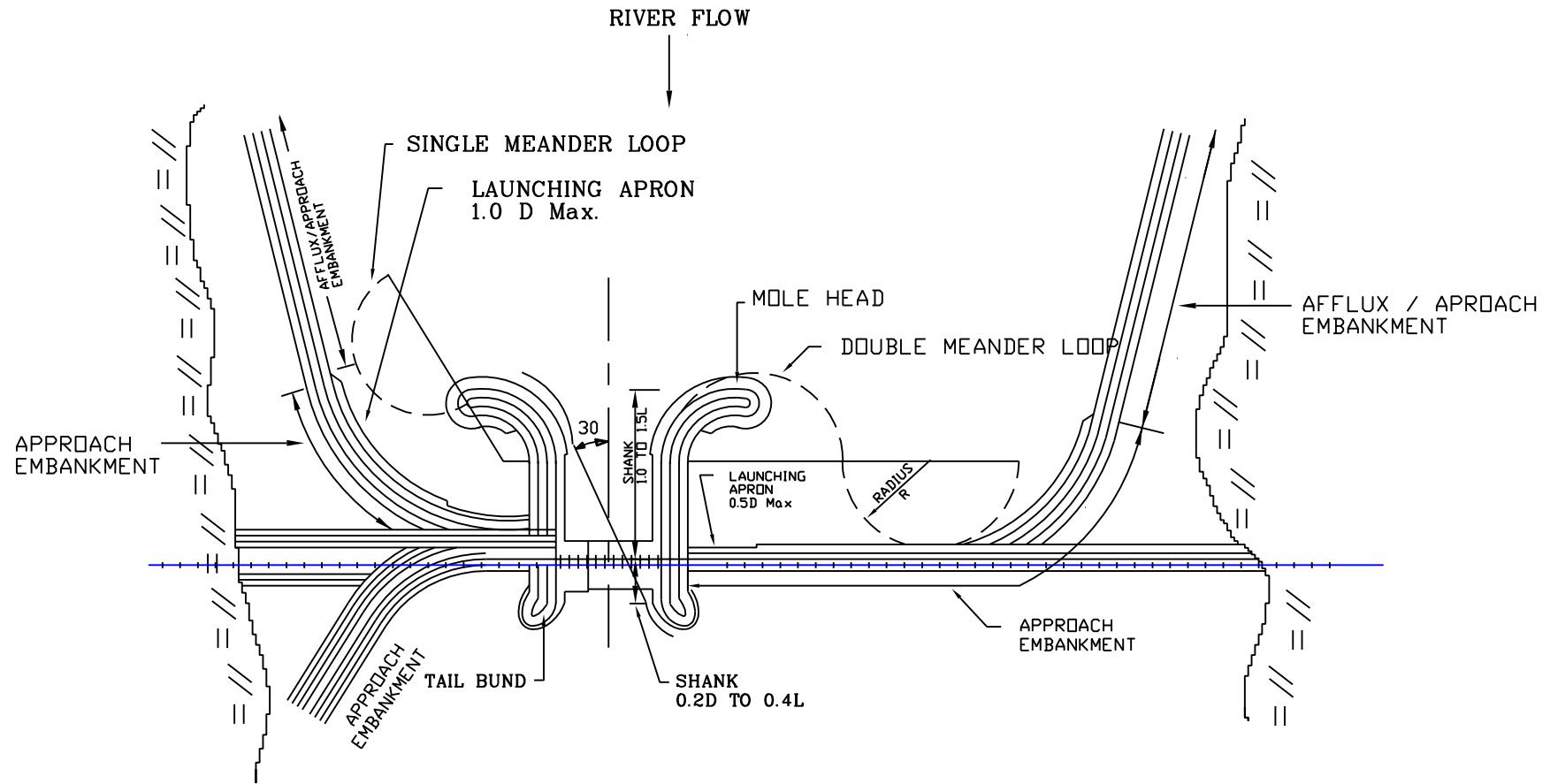

D Max = MAXIMUM ANTICIPATED SCOUR DEPTH  
BELOW LOW WATER LEVEL

गाइड बंध का विशिष्ट विन्यास  
TYPICAL LAYOUT OF GUIDE BANK

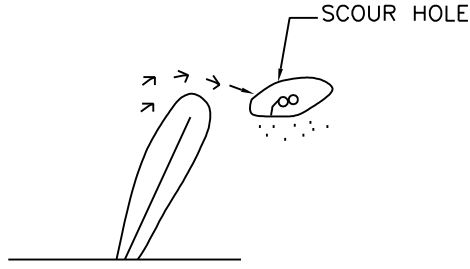

खींचने वाले स्पर  
ATTRACTING SPUR

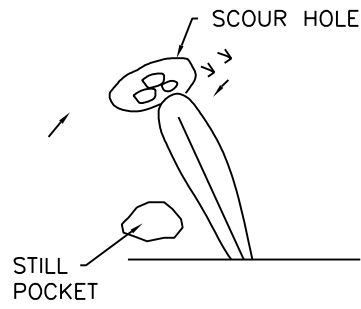

झुके हुए स्पर  
REPELLING SPUR

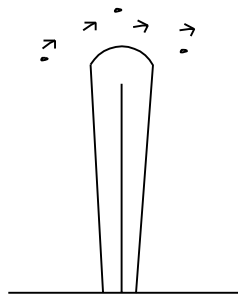

तलघट स्पर (संतुलित)  
SEDIMENTING SPUR  
(NEUTRAL)

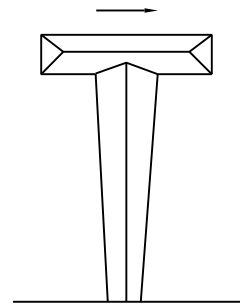

टी-शीर्षी स्पर  
T-HEADED SPUR

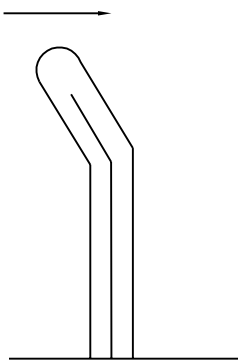

हॉकी स्पर  
HOCKEY SPUR

स्पर या ग्रायोनिस के प्रकार  
TYPES OF SPURS OR GROYNES

---

**Annexure 9/1**  
**Para 901**

**Structural Steel Inspection Register**

\_\_\_\_\_ Railway \_\_\_\_\_ Division

\_\_\_\_\_ Workshop \_\_\_\_\_ Locoshed

(Diesel/ Steam / Electric) at \_\_\_\_\_

Description of structure \_\_\_\_\_ Date of erection \_\_\_\_\_

Type of Truss \_\_\_\_\_ Details of column \_\_\_\_\_

Span in metres \_\_\_\_\_ Height of columns (m) \_\_\_\_\_

Details of foundation \_\_\_\_\_

Date of inspection	Condition of structure at the time of inspection	Action taken for rectification	Signature of inspecting official
1	2	3	4

---



---

**Annexure 10/1**  
**Para 1003**  
**Sheet No. 2**

**TUNNEL INSPECTION REGISTER**

An Index to be opened in the register giving the tunnel No. and Page No. etc.

Index		
Page No.	Kilometreage (Mileage)	Tunnel No.

**Annexure 10/1**  
**Para 1003**  
**Sheet No. 3**

**DETAILS OF TUNNEL**

Separate pages should be allotted for each tunnel and the following details should be furnished for each one of them

Tunnel No \_\_\_\_\_ Section \_\_\_\_\_ Between stations. \_\_\_\_\_

Total length \_\_\_\_\_ Kilometreage. \_\_\_\_\_

Year of Construction \_\_\_\_\_

Curve / Straight \_\_\_\_\_ Details of construction \_\_\_\_\_

Brief particulars of soil met with \_\_\_\_\_

Portions lined and thickness of lining \_\_\_\_\_

Brief particulars of ventilation \_\_\_\_\_

Brief particulars of lighting ( if any) \_\_\_\_\_

Brief particulars of drainage \_\_\_\_\_

Minimum height above rail level along centre line of track/s \_\_\_\_\_ millimetres.

Minimum distance from centre line of track/s \_\_\_\_\_ millimetres.

Reference to Plan. \_\_\_\_\_

---

---

### Previous History of Tunnel

Here all the records, such as details of damage to the tunnels and the repairs, if carried out with cost, special care to be taken in the maintenance of tunnel etc. are to be shown.

**Annexure 10/1**

**Para 1003**

**Sheet No. 4**

### Extract of page of Tunnel Inspection Register

Details of Inspection	Year 1997 - 98			Year 1998-99		
	Date of Inspection	Condition at the time of Inspection	Action taken and initials	Date of inspection	Condition at the time Inspection	Action taken and initials
1	2	3	4	5	6	7
1. Tunnel approach & cutting						
2. Condition of portals						
3. Tunnel walls & roofing. Comment about tunnel conforming to moving dimension						
4. Drainage inside tunnel and out fall						
5. Condition of tunnel refuges & ventilation shafts						
6. Tracks in the tunnel						
7. Lighting equipment & tools						
8. Any other items						

---

---

**Annexure 10/2**

**Para 1011**

**Proforma of the Register of vulnerable cuttings**

**Particulars of cuttings**

Name of section \_\_\_\_\_ and reference to authority for nominating it as vulnerable. \_\_\_\_\_

No. \_\_\_\_\_ Date \_\_\_\_\_

No. of cutting	Kilometre From /To	Max depth/ side slopes	Degree of curvature if any	Type of strata	Past History of cutting
1	2	3	4	5	6

**Inspection Details**

Date of Inspection	Remarks Of PWI	Date Of Insp.	Remarks of AEN	Date Of Insp.	Remarks Of DEN	Action Taken by PWI.
1	2	3	4	5	6	7

---

---

**Annexure 11/1**

**Para 1102.2**

**INSPECTION REGISTER FOR STEEL WORKS IN BRIDGES**

**Index**

S.No.	Bridge No.	K.M.	Between stations	Details of spans etc.	Page Nos.	
					From	To
1	2	3	4	5	6	7

**Annexure 11/2**

**Para 1102.2**

**INSPECTION REGISTER FOR STEEL WORK IN BRIDGES**

(For steel bridges of 12.2 m span and over and other nominated bridges)

Bridge No .\_\_\_\_\_ at km.\_\_\_\_\_ Section\_\_\_\_\_

Name of river if any:\_\_\_\_\_ Distance from Rail level to :\_\_\_\_\_

Type of Bed Blocks :\_\_\_\_\_ i) Bottom of girders \_\_\_\_\_

Type of bearings :\_\_\_\_\_ ii) Top of bed blocks \_\_\_\_\_

iii) Bed level \_\_\_\_\_

Year of manufacture:\_\_\_\_\_ Super elevation \_\_\_\_\_

Year of erection : \_\_\_\_\_ Materials of girders \_\_\_\_\_

Angle of skew \_\_\_\_\_

**Details of spans**

Span No.	Clear span	Centre to centre of bearings	Overall length	Drawing No.	Type	Strength of girder as per Bridge Loading standards
1	2	3	4	5	6	7

---

Previous history of steel work of bridge.

Date of inspection	Condition of girders (indicate creep, camber and distortion of girders if any)	Date last greased	Condition of bearing seating and lubrication	Condition of bed blocks and H.D. bolts
1	2	3	4	5

Condition of rivets and welds (details to be entered in Loose Rivet Register and Weld Register)	Date last painted		Condition of paint and corrosion	Condition of deck slab in case of composite girders	Condition of smoke guards / drain
	Patch	Full			
6	7 (a)	7 (b)	8	9	10

Any serious condition requiring attention	Details of repairs etc. attended to during the year	Signature of Bridge Inspector	Remarks by ABE, XEN / Bridges or DEN / Bridges	Orders by Deputy Chief Engineer / Bridges
11	12	13	14	15

---

**Annexure 11/3**  
**Para 1103.4**

**BRIDGE INSPECTION REGISTER**

1. Instructions for inspection purpose : Para 1107 of the Indian Railway Bridge Manual may be got printed on the Bridge Inspection Register which details out the instructions for inspection purposes.

2. Instructions for entering the Bridge Register :

a) Under each heading entry should state whether the previous year's notes have been attended to.

b) Entries in the column "Condition of bridge at the time of inspection" should be in the nature of statements. A defect once mentioned should not be omitted in future years unless it has been eliminated by rebuilding or repair in which case a note should be made to that effect.

c) In the column "Action taken", the remarks should be in the form that orders have been issued, e.g.

i) Permanent Way Inspector instructed to renew sleepers,

ii) Bridge Inspector instructed to carry out painting.

d) No bridge which is cracked or in which the masonry is shaken, crushed, bulging, deteriorating or showing signs of movement or in which the steel work is affected should be described as "sound".

e) Should it be impossible to make complete inspection of any bridge owing to the presence of standing water, the fact should be recorded. The inspection of foundations should be made no sooner water dries up or conditions make it possible to do so and results recorded as supplementary entries in the Bridge Inspection Register.

---

**INDEX OF BRIDGES**

Section \_\_\_\_\_ DN/UP \_\_\_\_\_

From Km \_\_\_\_\_ To Km \_\_\_\_\_

<b>Page No.</b>	<b>Bridge No.</b>	<b>Page No.</b>	<b>Bridge No.</b>
1		25	
2		26	
3		27	
4		28	
5		29	
6		30	
7		31	
8		32	
9		33	
10		34	
11		35	
12		36	
13		37	
14		38	
15		39	
16		40	
17		41	
18		42	
19		43	
20		44	
21		45	
22		46	
23		47	
24		48	& so on ...

---

पायों, पीलपायों, गर्डरों, मेहराबों आदि के  
अंकन दर्शाने वाली सामान्य योजना

**GENERAL KEY PLAN**  
**INDICATING THE NUMBERING OF PIERS, ABUTMENTS**  
**GIRDERS, ARCHES, ETC.**

DIRECTION OF INCREASING KILO-METRAGE →

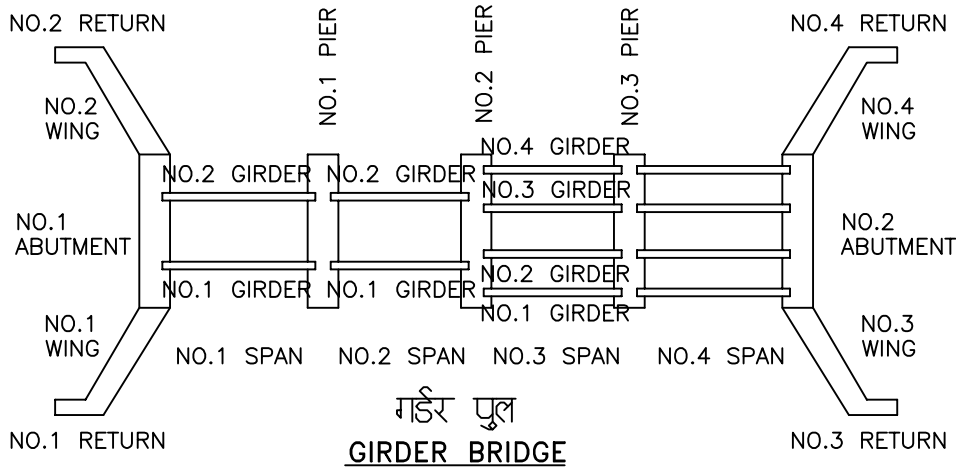

**NOTE:—**

WHERE THERE ARE MORE TRACKS THAN ONE THE GIRDERS ARE TO BE NUMBERED CONSECUTIVELY COMMENCING FROM THE EXTREME RIGHT FACING THE DIRECTION OF INCREASING MILEAGE

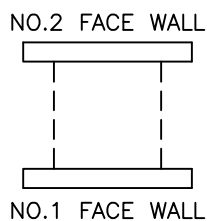
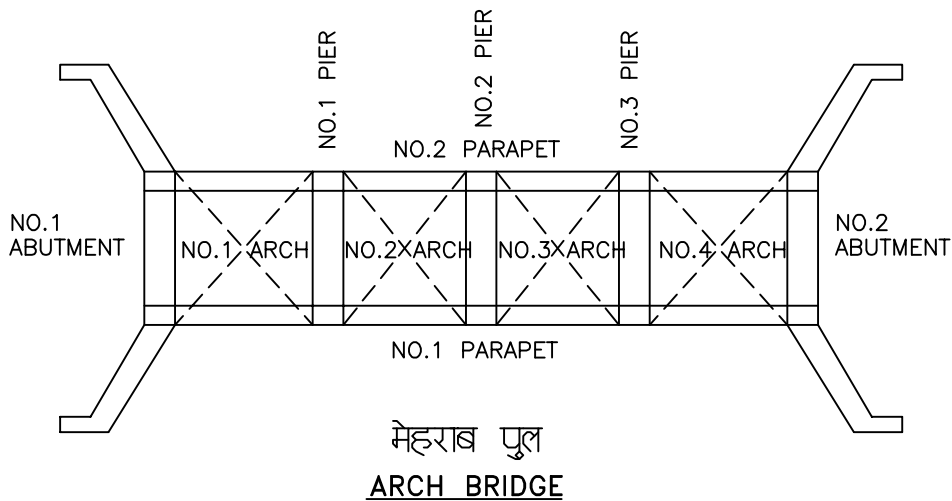

पृष्ठ दीवार सहित कलवर्ट  
**CULVERTS WITH FACE WALLS**



---

**Annexure 11/6****Para 1103.4****CLASSIFICATION OF STRUCTURES**

<b>Classification of Structure</b>	<b>Description</b>
Earthenware pipe -	-
Reinforced concrete pipe -	-
Cast iron pipe -	-
Rail opening -	Clear opening with no girder of any kind between the abutments
Timber top opening -	Permanent Way carried on longitudinal timbers
Timber top opening cross sleeperd -	Permanent Way on cross sleepers on longitudinal timbers
Slab top culvert -	Stone slabs
RCC slab top culvert -	Reinforced concrete slab with cushion of ballast
PSC slab top culvert -	Prestressed concrete slab with cushion of ballast
RCC box culvert -	Reinforced concrete box culvert
RCC T-beam bridge -	Reinforced concrete T-beam and slab bridge
Arch bridge -	Arch: open spandrel or spandrel filled
RSJ girder bridge -	Steel Joists with or without flange plates and with cross sleepers carrying the permanent way
Deck plate girder -	Single or duplicate girders with cross sleepers on top flanges

---

Half through plate girder bridge -	Plate girders with track on cross girders and stringers or steel troughing or closely spaced cross beam
Deck triangulated girder -	Triangulated girders with Permanent Way carried on top
Half through triangulated girders or pony girder -	Triangulated girders with no over head bracing and with track carried on cross girders and stringers between bottom booms
Through triangulated girder -	Triangulated girders with overhead bracing track carried on floor system between bottom booms
Composite girder bridge -	Steel plate girders with RCC decking
PSC girder bridge -	Prestressed concrete girder bridge
Girder road over bridge -	Iron or steel girder bridge over the line
Arch road over bridge -	Arch bridge over the line
RCC/PSC road over bridge -	Reinforced concrete/prestressed concrete bridge over the line
Foot over bridge -	Iron, steel or RCC foot over bridge over the line.

**Note** :- A bridge on the skew should have the word 'skew' entered against type of bridge and its span, square and skew should be given.

---

**Annexure 11/7**

**Para 1103.4**

**INSCRIPTION PLAQUES ON BRIDGES SHOWING  
NATURE AND DEPTH OF FOUNDATIONS.**

On all bridges of 3 m (10 ft.) span or over, particulars of the nature and depth of foundations should be inscribed on a CC or stone slab fixed on each pier and abutment.

1. The information to be recorded should be :

- a) Nature of foundation e.g. wells, piles and open,
- b) Nature of strata passed through and reached,
- c) Depth from rail level to the bottom of foundations and top of foundations.

2. The following abbreviations should be used in the inscriptions:

WL	Well foundation
ON	Open foundation
SP	Screw Pile foundation
TP	Timber pile foundation
CP	Concrete pile foundation
IC	Iron cylinder
SC	Steel cylinder
CN	Concrete
CCN	Cement Concrete
PSC	Prestressed concrete
BF	Bottom of foundation
TF	Top of foundation
TA	Top of apron
TI	Top of invert
BD	Bottom of drop wall
RL	Rail level
RL-BF	Depth from rail level to bottom of foundation
RL-TF	Depth from rail level to top of foundation
S	Sand
C	Clay
G	Gravel or shingle

---

---

M	Moorum
R	rock
BC	Black cotton soil
K	Kunker
A	Alluvium

3. Other symbols may be used if required such as :

WW	Wing wall
US	Up stream
DS	Down stream
TP	Top of pitching
BP	Bottom of pitching
WN	Wire netting
CW	Crib work

4. For example a plaque inscribed thus and built on top of pier :

WL	
RL - BF	74
RL - TF	34
S	25
C	15

Will indicate that the pier is founded on a well, the bottom of which is at 74 ft below rail level and top 34 ft below rail level and that 25 ft of sand and 15 ft of clay were passed through and the well rested on clay. If the inscriptions had been made after the metric measurements came into force, the numbers on the inscription will indicate the depths in metres and to distinguish from FPS units, letter "m" should be added e.g. RL-BF 20m.

5. On bridges already built it may be impossible to give so much details, in that case a simple inscription such as

RL - BF 69  
R  
will suffice

This will indicate that the foundation is on rock at a level of 69 ft below rail level.

Note : Most of the existing bridges contain plaques with inscriptions in FPS Units. On new bridges, plaque inscriptions in MKS Units should be adopted.

---

**Annexure 11/8**

**Para 1103.4**

**PROFORMA FOR MAJOR AND IMPORTANT BRIDGES**

1. General :

Division\_\_\_\_\_Sub Division\_\_\_\_\_Section\_\_\_\_\_

Br. NO.\_\_\_\_\_ Span details\_\_\_\_\_

Name of river \_\_\_\_\_ Class of structure\_\_\_\_\_

Type of girder \_\_\_\_\_ strength of girder\_\_\_\_\_

Rail level \_\_\_\_\_ m High flood level \_\_\_\_\_ m

Danger level \_\_\_\_\_ m

Bottom of girder/slab or crown of arch \_\_\_\_\_ m

Abutment : \_\_\_\_\_ Materials of construction \_\_\_\_\_

i) (with splayed wing walls)

ii) (with parallel wing walls)

Pier : Type \_\_\_\_\_

Strength of : Piers \_\_\_\_\_

Abutments \_\_\_\_\_

Wing walls \_\_\_\_\_

Depth of cushion \_\_\_\_\_ m below bottom of sleeper

(for arch slab top and pipe bridges only)

2. Previous history regarding high flood, scour, erosion, suspension of traffic etc.

3. Record of afflux : \_\_\_\_\_ Year \_\_\_\_\_ Max.afflux \_\_\_\_\_

4. Foundation details \_\_\_\_\_ Velocity of flow \_\_\_\_\_

Pier / Abutment	Details of wells/ piles/open	B.F	T.F.	Bed level	Floor level	Thickness of floor	Safe scour limit
1	2	3	4	5	6	7	8

5. Description of protection works (wherever provided)

Description	UP stream		Down stream	
	Left	Right	Left	Right
i) Length of guide bund ii) Crest level of guide bund iii) Crest width iv) Width and depth of apron v) Thickness of pitching vi) Width and depth of nose of guide bunds vii) a) Depth below floor level and distance from the centre line of bridge of curtain wall b) Drop wall Deepest known scour, year and its location				

6. In the case of bridges with railway affecting works, the following details may be recorded :

- i) Tank and its capacity and distance from bridge
- ii) Dam/weir across river, its designed discharge and distance from bridge
- iii) Details of marginal bunds
- iv) Details of road/canal running parallel

7. Key plan of the bridge.

**Annexure 11/9****Para 1103.4****PROFORMA FOR INSPECTION OF MAJOR AND IMPORTANT BRIDGES****CONDITION OF THE BRIDGE AT THE TIME OF INSPECTION**

Date of inspection	Foundation and flooring extent of scour and damage.	Masonry Condition, extent of defect in substructure	Protective works and waterway scour, slips or settlements, sanctioned reserve available and whether waterway is clear	Bed Blocks Cracks, tendency to move
1	2	3	4	5

Girder Bearings & expansion arrangement	Steel work in the case of steel/composite girder bridge structural condition and stage of painting.	PSC/Concrete / Composite girder in superstructure Condition of girders / beams, any cracks or defects noticed, condition of slabs /decks	Sleepers, Year of laying. condition and renewals required	Line & Level
6	7	8	9	10

Track on bridge			Drainage arrangements on ballasted deck and arch bridge	Track on approaches Approach slabs, ballast walls & rails, earth slopes, etc.
Bearing plates & their seating	Guard rails	Hook bolts		
11	12	13	14	15

Other items like trolley refuges/foot paths, fire fighting equipment etc.	Action taken on last year's notes	Initial of inspecting official and URN	Initials of higher officials with remarks
16	17	18	19

---

Annexure 11/10

Para 1103.4

**FOR MINOR BRIDGES**

**Details of the Bridge**

**Minor Bridges :**

Division\_\_\_\_\_Sub division\_\_\_\_\_Section\_\_\_\_\_

Bridge No\_\_\_\_\_Span details\_\_\_\_\_No.\_\_\_\_\_m

Name of river if any \_\_\_\_\_ Class of structure \_\_\_\_\_

Type of girder / slab \_\_\_\_\_ Strength of girder / slab \_\_\_\_\_

Rail level \_\_\_\_\_ m. HFL \_\_\_\_\_ m

Danger level \_\_\_\_\_ m

Bottom of girder/slab\_\_\_\_\_ m

Abutment\_\_\_\_\_Material of\_\_\_\_\_Strength  
Construction

(With splayed wings) \_\_\_\_\_

(With parallel wings) \_\_\_\_\_

Depth of cushion\_\_\_\_\_ m below bottom of sleeper.

(Arch, slab top & pipe bridges only)

**Foundation details** (Reduced level)

Bottom of foundation\_\_\_\_\_ m

Floor or bed level \_\_\_\_\_ m

Thickness of floor \_\_\_\_\_ m

Bottom of drop wall/curtain wall \_\_\_\_\_ m

Record of afflux, year and velocity \_\_\_\_\_

Deepest known scour (if any), year and location\_\_\_\_\_

Space for key plan of the bridge

---



---

**Annexure 11/11**  
**Para 1101.2 & 1103.4**

**PROFORMA FOR INSPECTION OF MINOR BRIDGES**

Date of inspection	Condition of bridge at the time of inspection	Action taken on the previous year's notes	Initial of inspecting officer with remarks if any	Initials of higher officials with remarks if any
1	2	3	4	5

**Annexure 11/12**  
**Para 1107.5**

**PROCEDURE FOR RIVET TESTING**

1. To test whether a rivet is loose, a left hand finger should be placed on one side of the snap head of the rivet and on the other side smartly tapped with a light hammer (110 gm testing hammer). If the rivet is loose, vibrations will be felt by the left hand finger. The snap head should be tapped in two or three different directions. Rivets are normally tested on their dolly side and the loose rivets shall be marked with red paint immediately after the testing for easy identification.

2. Schedule for testing of rivets :

A rational system of sample testing of rivets as detailed below shall be adopted. The rivets in any particular type of girder span will be divided into "Categories" for purposes of "sample testing". The Bridge Inspector is required to test 24 rivets only in each category in the first instance and only in those cases where the result of this first test is not upto standard he is required to test another 24 rivets on the particular span due for test. The details of the categories for various types of girders are shown in para 3 below.

---

### 3. Categorisation of joints for sample testing of rivets

#### a) Plate girders :

- i) Plate girders under 12.2 m nominal length will not be included in the rivet test programmes. No routine tests need be carried out on such spans but Bridge Inspectors will during their detailed inspections of all steel work, satisfy themselves that the few rivetted connections (particularly in bracings) are in efficient order.
- ii) Plate girder of 12.2 m and over nominal length will have samples of their rivets taken in the categories detailed as follows :

Ref.No.	Details of category	Remarks
F.1	Rivets connecting rail bearers over which fish joint occurs, to cross girders.	12 rivets from each end of such rail bearers to be tested.
F.2	Rivets connecting rail bearers where no fish joint occurs.	-----do----- Rivets in end rail bearers not to be included in sample.
F.3	Rivets connecting cross girder, near which fish joint occurs, to post.	12 rivets from each end of such cross girder to be tested.
F.4	-----do----- where no fish joint occurs	-----do----- Rivets in end cross girders not to be included in sample.
B.1	Rivets connecting member of vertical bracings to gussets.	24 rivets taken at random from gussets near ends of span.
B.2	Rivets connecting member of horizontal bracings to gussets of main girders.	24 rivets taken at random from gussets near ends of span.
G.1	Rivets connecting flange angles to web plate over bearings.	12 rivets from upper flange and 12 rivets from lower flange.
G.2	Rivets in web splice cover plates.	Any 24 rivets.
G.3	Rivets in flange plate splice cover plates.	Any 24 rivets from upper flange only.

b). Triangulated spans :

The various "categories" from each of which a sample of 24 rivets is to be selected and tested are :

Ref. No	Details of category	Remarks
F.1	Rivets connecting rail bearers, over which fish joint occurs.	12 rivets from each end of such rail bearers to be tested.
F.2	Rivets connecting rail bearers where no fish joint occurs.	12 rivets from each end of such rail bearer to be tested. Rivets in end rail bearers not to be included in sample.
F.3	Rivets connecting cross girder, near which fish joint occurs, to post.	12 rivets from each end of such cross girder to be tested.
F.4	-----do----- Where no fish joint occurs.	-----do----- Rivets in end cross girders not to be included in sample.
B.1	Rivets connecting member of vertical bracing to gusset of main girders.	24 rivets taken at random from gussets near ends of span.
C.1	Rivets in upper chord.	24 rivets to be taken from each typical main splice.
C.2	Rivets in lower chord main splice joints, etc.	24 rivets to be taken from each typical main splice.
P.1	Rivets for connecting post to chords - first post	12 rivets from each end of post
P.2	---do-- second post	---do---
P.3	---do--- third post	---do---
P.4	Etc. Etc. middle post	---do---
D.1	Rivets connecting diagonal to chord's first diagonal	12 rivets from each end of diagonal.
D.2	Rivets connecting diagonal to chords-second diagonal	12 rivets from each end of diagonal.
D.3	---do--- third diagonal	---do---
D.4	Etc. Etc. middle diagonal	---do---

---

4. Instructions for sampling :

a) It must be emphasised that the "samples" need not necessarily be in one group of rivets; if, for instance, there are only seven rivets in the rail bearer end connection then the sample of 12 must be made by including 5 rivets in the corresponding end of another rail bearer. Indeed, it would be permissible to test one rivet in the end of every rail bearer in the span (except the end rail bearers) if the span contained as many as 16 rail bearers (i.e. 8 panels). But such a procedure would not normally be adopted because it would demand so much staging.

b) The same remarks apply to cross girder end connections and the ends of web members, even when the total number of rivets in the particular joint is far in excess of the number required for the "sample". There is no objection to the sample being made up of any four rivets in the outer gusset and eight in the inner gusset.

c) All the rivets taken as a sample by the Bridge Inspector in any category must be painted with a white mark on the head. Those found loose and very loose should have in addition a white ring round them for easy identification/verification.

5. Rivet Test Register :

Result of sample test will be recorded in the Bridge Inspector's Rivet Test Register as per proforma at Annexure 11/13.

**Annexure 11/13**

**Para 1102.2**

**SAMPLE RIVET TEST REGISTER**

Bridge No. \_\_\_\_\_ Span No. \_\_\_\_\_ at km \_\_\_\_\_

Girder type & No \_\_\_\_\_ Nominal length \_\_\_\_\_

Date of test \_\_\_\_\_

Rivet category	Tight rivets and slightly loose rivets	Loose rivets and very loose rivets	Signature of BRI

**Note :** 1. For details of rivet categories refer to the note printed in the Annexure 11/12.

2. Loose rivet diagram to be given for identification of joints.

---

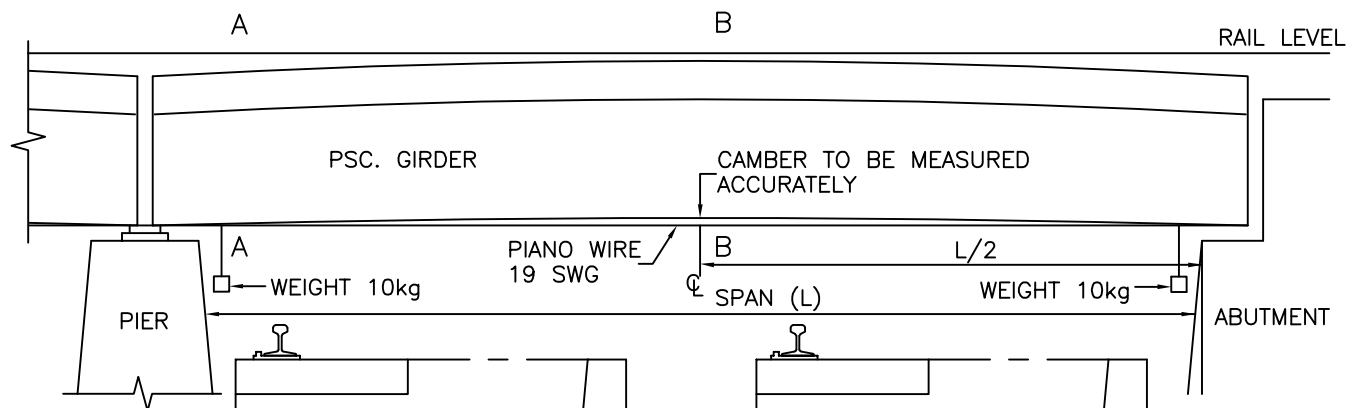

THE DISTANCE FROM THE CENTRE LINE OF BEARING TO THE HANGING WEIGHT SHOULD BE SAME AT BOTH ENDS

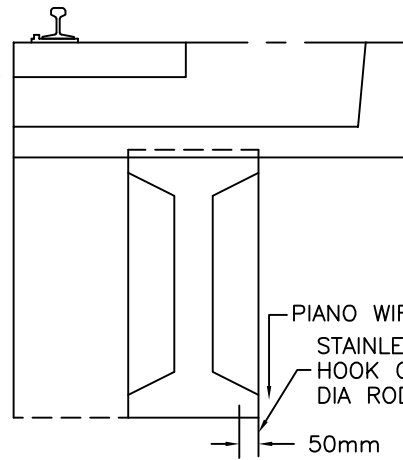

CROSS SECTION AT A-A

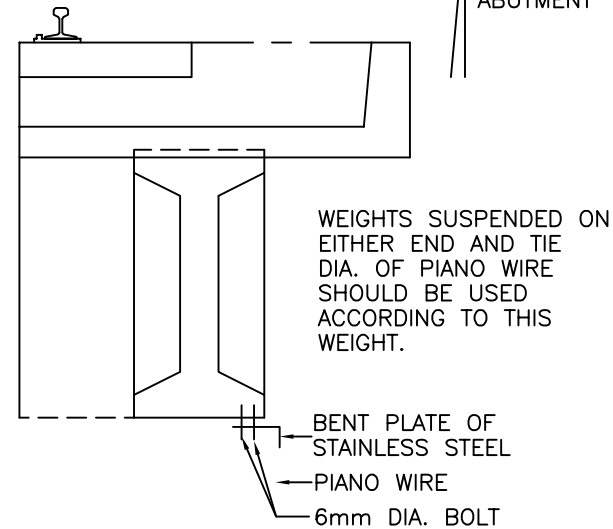

CROSS SECTION AT B-B

WEIGHTS SUSPENDED ON EITHER END AND TIE DIA. OF PIANO WIRE SHOULD BE USED ACCORDING TO THIS WEIGHT.

पी.एस.सी. गर्डर का कैम्बर मापने की पद्धति  
P.S.C. GIRDERS CAMBER MEASURING METHOD

**Annexure 11/15****Para 1109****TOOLS AND EQUIPMENT FOR INSPECTION OF BRIDGE**

Sl. No.	Tool/Equipment	Purpose	Required For *
1	2	3	4
1.	Rivet testing hammer (110g)	For testing looseness of rivets	A,B,C, D,E
2.	Inspection cum chipping hammer	For checking hollow pocket/ honeycomb in masonry and concrete structure including PSC by tapping and for examining the extent of corrosion, adherence of paint on girders, and for removing loose scales	A,B,C
3.	Elcometer (coating thickness gauge)	For measuring thickness of paint, metalised coating, etc.	A or B
4.	Pocket steel tape (3m)	For measuring gap between girders or between girder and abutment, dimension of steel members, size of cracks, etc.	A,B,C
5.	Straight edge (1m)	For checking deformation/ distortion/buckling of steel components, bulge of masonry structure, etc.	A,B,C
6.	Metallic tape (30m)	For taking measurements such as clear span, overall length of girders, etc.	A,B,C D,E
7.	Log line with 20 kg. lead ball	For measuring scour depth, lifting/lowering of tools and tackles for examination purpose, etc.	B (as required)
8.	Probing rod	For checking firmness of ground and scour measurements	B

9.	Calliper (inside)	For measuring the thickness of steel sections, dia. of solid/	A,B,C
10.	Calliper (outside)	hollow pipes, dia. of rivets/ bolts/holes, etc.	A,B,C
11.	Set of feeler gauges (0.1 to 5mm)	For measuring the width of fine cracks and cavity between parts or adjacent components	A,B,C
12.	Mirror (10 x 15 cm)	For inspecting parts in any awkward location by reflection method and to lit objects in dark location by directing Sun rays to facilitate inspection	A,B,C
13.	Torch light (5 cell)	Used alongwith mirror for identification of fine cracks in dark location; for safe passage through tunnels and other dark areas, etc.	A,B,C
14.	Magnifying glass (100 mm dia.)	For identifying very fine cracks in members/welds which may not be visible with naked eyes	A,B,C
15.	Piano wire with Clamps and 2 Nos. 10 kg. weight	For measuring camber in PSC girders, etc.	A
16.	Plumb bob	For checking verticality of girder member/pier/ abutment/trestles, etc.	A,B,C
17.	Chisel	For removing unwanted hard deposits like concrete, etc. for inspection/maintenance purposes	A
18.	Steel scrapper	For scrapping rust/dirt/ paint for inspection, for pretreatment to dye penetration tests of welds, etc.	A
19.	Thermometer	For recording temperature at the time of measuring camber, for the purpose of setting of bearings at the desired position.	A

20.	Spirit level	For checking gauge and cross level of track on bridges or at bridge approaches, for proper setting of girders on bearings, etc.	A
21.	Binoculars	For inspection of bridge components which are at inaccessible location, tall piers, arches in viaducts, etc. prior to closer examination.	D
22.	Current meter	For measuring velocity of water	D,E
23.	Echo sounder	For measuring depth of water, for assessment of scour	E
24.	Schmidt's concrete testing hammer	For assessing the strength of concrete structure by NDT method	D, E
25.	Concrete cover meter	for assessing the cover available to reinforcement in existing RCC structures by NDT method	E
26.	Dial gauge	For measurement of deflections in case like load testing of arch/ steel / PSC bridges, etc.	E
27.	Dye penetration kit	For inspection of welded bridges	E
28.	Magnetic crack detector		
29.	Welding gauges		
30.	Helmet	For safety of the inspecting officials	A
31.	Safety belt		
32.	Fibre glass boat **	To facilitate access to bridge structure located in water, etc.	B

\*The following notations have been adopted regarding supply of gadget / equipments :

A - BRI	B - PWI	C - AEN
D - Divisional Hd. Qrs.	E - Zonal railway Hd. Qrs.	

\*\* Only for officials who have bridges with large waterways requiring the use of boats to be decided by CBE.



---

**Annexure- 12/1**

**Para 1215**

**FORM OF AGREEMENT FOR HIRE OF PLANT**

AN AGREEMENT made this \_\_\_\_\_ day of \_\_\_\_\_ 199.

BETWEEN the President of India acting through the Chief Engineer \_\_\_\_\_ Railway (hereinafter called the "Railway") which expression shall include his successors and assigns unless the context requires a different construction ) of the one part and whose permanent registered postal address is \_\_\_\_\_

(hereinafter referred as the "Hirer" which expression shall include his heirs, legal representative and assigns unless the context requires a different construction) of the other part.

Whereas at the request of the Hirer the Railway has agreed to the hire of plant specified in Appendix 'A' hereto subject to the terms and conditions hereinafter mentioned, it is hereby mutually agreed by and between the parties hereto as follow:

1. Delivery of the plant shall be at the plant Depot \_\_\_\_\_ and the Hirer shall remove and return the plant from and to the same point at his own cost.

2. When the plant or the material is carried by rail, the carriage charges shall be at public tariff rate.

3. The Hirer shall pay hire charges calculated at the rate mentioned in Appendix ~A~ hereto. The hirer shall be charged from the date of delivery of the plant in the plant Depot \_\_\_\_\_ to the date of its return to the same point both dates to be included in the period of hire and the period being calculated in days, part of a day being reckoned as one day.

4. The Hirer shall pay in addition to the hire charges, actual costs (which shall include book rate or the current market rate which ever is higher plus 7 % or such other percentage as may be prescribed by the Railway towards freight and incidental charges on the value of stores

---

---

utilised for packing ) plus 12-1/2% supervision charges of all packing, handling, loading, unloading or other direct charges incurred by the Railway in dispatching or receiving back the plant and materials.

5. a) The estimated charges towards the hiring of the plant and material shall, at the discretion of the Railway. Be paid by the Hirer, if he is not a Railway or Government Department in advance to the Financial Adviser and Chief Accounts Officer \_\_\_\_\_ Railways \_\_\_\_\_ and on return to the plant and materials to the plant Depot, the amount of hire charges deposited in excess if any, by the Hirer will be refunded to him and excess of hire charges, if any, due from the Hirer shall also forthwith be paid by him on demand.

b) In the case of Hirer other than a Railway Department, the Railway may, at its discretion , demand the deposit of the entire cost of the plant hired in addition to the hire charges referred to above.

c) In the case of other Government Departments, the hire charges for a plant and materials as well as well as other charges shall be adjusted through the adjusting accounts.

6. In the event of the Hirer requiring the use of the plant for a further period than previously agreed to and paid for by him, the Hirer shall obtain the prior approval of the Railway thereto and shall pay the hire charges due for such extended period, in advance to the Financial Adviser and Chief Accounts Officer, \_\_\_\_\_ Railway \_\_\_\_\_

7. The Hirer shall satisfy himself when taking over the plant that it is in satisfactory working order. He shall be liable to replace at his own cost wearing parts such as washers, packings, pump buckets and gauge-glasses which may require replacement during the period of hire. Appendix 'B' shows particulars of such wearing parts of the plant hired out. Spare parts for such replacements shall be obtained only from the Railway which will supply them ex. the plant Depot \_\_\_\_\_ at book rates or market rates (Current purchase rate) which ever is higher plus freight and supervision charges at rates prescribed by the Railway. If such spare parts are required to be sent by the Railway, they will be booked to the Railway station nearest the point where the plant is stationed, at public tariff rates, to be borne by the Hirer. The Railway

---

---

may at its discretion permit the purchase of the spare wearable parts from outside sources provided it is satisfied that the parts correct to specification only will be used.

8. In the case of breakage or loss of any part of accessory other than the parts liable to wear out referred to in the Appendix 'B', the cost of replacement shall be shared between the Railway and the Hirer in accordance with the rules in this respect in force on the Railway from time to time. The share to be borne by Railway as determined in accordance with the rules in force on the Railway shall be final and conclusive.

9. In the event of the loss of the entire plant, the cost shall be divided between the Hirer and Railway on the basis laid down in rules in force on the Railway from time to time. The cost that may be determined by the Railway shall be final and the Hirer shall pay his share of the cost to the Railway.

10. The Hirer shall not make over, under-let or otherwise transfer or part with, the whole or any part of the plant and materials taken on hire without the consent in writing of the Railway which shall have absolute discretion to grant refuse such consent and at any time revoke such consent, if given. Such consent shall not relieve the Hirer of any of the responsibilities or obligations under this agreement.

11. During the period the plant is on hire with the Hirer, the Hirer shall be responsible to ensure that any inspection certificate or license required under any Government Act for the time being in force is obtained in due time. The Hirer shall also be responsible for seeing that all required precautions are observed in using the plant and for any accident which may occur from the use of the plant.

12. The Railway shall be given all reasonable access to the plant and such facilities as may be necessary to satisfy itself that the plant is being so used as to avoid any unnecessary wear or loss or under risk.

13. The Railway reserves to itself the right to recall the plant without assigning any reasons by giving two week's notice to the Hirer or at any time without notice in the event of its being required by the Railway for an unforeseen emergency. In either case the Railway shall not be

---

---

liable to pay any compensation to the Hirer for the loss that may be caused by the withdrawal of the plant.

14. The Hirer shall make his own arrangements for the supply of consumable stores required for working the plant.

15. The Railway may, if it desires on request by the Hirer provide the staff for working the plant hired and the Hirer shall pay the salaries and allowances payable to the staff employed in working the plant together with such other charges as provident fund, bonus leviable in accordance with the rules of the Railway.

16. In the event of the Railway unable to provide the staff required for working the plant hired, the Hirer shall make his own arrangements for working the plant and the Hirer shall obtain from the Railway a certificate of competency for the staff employed by him in working the plant hired.

17. The Hirer shall observe and act upon the provisions of the Workmen's Compensation Act, Payment of Wages Act, the Factories Act and other acts of the Legislature that may be applicable to the working of the hired plant. He shall be liable to pay all such sum or sums that may become payable as compensations, penalty, fine or otherwise under the provisions of the various Acts referred to above and shall indemnify the Railway from and against all payments by way of compensation, penalty, fine or otherwise, which the Railway may be called upon to make, under the provisions of the said Acts to or on behalf of any workmen, by an authority empowered to levy the penalty or fine as aforesaid and any costs incurred by the Railway in connection with any claim or proceeding under the said Acts or in respect of any loss, injury or damages whatsoever to any third person arising out of or occasioned by the negligent, imperfect or improper performance of this Agreement by the Hirer, his workmen servants or agents.

18. On return of the plant, it shall be opened out and examined in the plant Depot———by the Railway and a statement prepared of any repairs or replacements other than those due to fair wear and tear which are considered necessary and the cost of such repairs and replacements shall be estimated and shown thereon. A copy of this

---

---

statement shall be sent to the Hirer who will be given reasonable opportunity to check the correctness of this statement by the examination of the plant. Such repairs and replacements as are agreed to be necessary over and above the fair wear and tear shall be shared between the Hirer and the Railway on the same basis as for breakage or loss mentioned in Clauses 8 and 9 here of. The Hirer shall in addition to the above also bear the charges towards cleaning, general overhaul and minor repairs found necessary due to fair wear and tear to the plant hired. The cost that may be determined by the Railway shall be final and the Hirer shall pay his share of the cost to the Railway.

19. Except as otherwise provided herein any arrangement or agreement, oral or written, abandoning, varying or supplementing this contract or any of the terms hereof shall be of no effect and shall not be valid or binding or enforceable on the Railway unless and until the same is endorsed on this contract or incorporated in a formal agreement in writing and signed by the parties hereto.

20. All disputes, questions, matters and things arising out of or in respect of the Agreement ( the decision whereof is not herein before mentioned) shall be decided by the General Manager of the \_\_\_\_\_ Railway in his sole and absolute discretion and his decision shall be final.

As witness the signature of the parties hereto, the day and year first above written.

Signed by \_\_\_\_\_  
for and on behalf of the  
President of India,  
in the presence of \_\_\_\_\_

} Chief Engineer \_\_\_\_\_ Railway

Witness:

Signed by \_\_\_\_\_  
(in the presence of )

Witness \_\_\_\_\_ Hirer \_\_\_\_\_

---

---

**APPENDIX 'A'**

**TO AGREEMENT FORM**

**(Para 1215)**

Schedule of hire charges to accompany Agreement  
No. \_\_\_\_\_

Dated. \_\_\_\_\_

Sr. No.	Description Of Material	Unit	Quantity	Rate of hire per month/day		Remarks
				In figures Rs. Paise	in words	

\_\_\_\_\_  
Hirer

\_\_\_\_\_  
Chief Engineer.  
**Appendix 'B'**

**TO AGREEMENT FORM**

**(Para 1215)**

List of wearable parts to Accompany Agreement No \_\_\_\_\_  
dated \_\_\_\_\_

Sr. No.	Description Of Materials.	Unit	Quantity	Remarks
1	2	3	4	5

\_\_\_\_\_  
Hirer

\_\_\_\_\_  
Chief Engineer.

---

**Annexure 14/1****Para 1401****List of Books of Reference**

Item No.	Publication	Offices which should be equipped with a copy of the publication				
		For the personal use of such Officers and Inspectors as may be prescribed by the Chief Engineer	Dy. Chief Engineer /Bridges Hd.Qrs. Office	Divisional Engineer's Office	Asstt. Engineer's Office	Bridge Inspector's Office
1	2	3	4	5	6	7
1	Act Indian Boilers and Manual of Boiler Inspection as issued	-	1	1	-	-
2	Act Indian Electricity and rules issued and State Government Publications.	-	1	1	-	-
3	Act Indian Explosive and State Government Publications	-	1	1	-	-
4	Act Indian Factories and State Government Publication	-	1	1	-	-

1	2	3	4	5	6	7
5	Act Indians Mines and State Government Publication	-	-	1	1	-
6	Act Indian Petroleum and State Government Publication and Petroleum rules	-	1	1	1	-
7	Act, Indian Railway	-	1	1	1	-
8	Act ,Land Acquisition and State Govt. Publications	-	1	1	1	-
9	Act, Payment of Wages with Notifications as issued	-	1	1	1	1
10	Act,Workmen's Compensation	-	1	1	1	1
11	Alphabetical list of Railway Stations	-	1	1	1	1
12	Code Indian Railway for the Engg. department	-	1	1	1	1
13	Code,Indian Railway for the Stores Department	-	1	1	-	-



1	2	3	4	5	6	7
14	Code, Indian Railway for the Mechanical Department	-	1	1	-	-
15	Code, Indian Railway for the Accounts Department	-	1	1	-	-
16	Code, Indian Railway Establishment	-	1	1	1	1
17	Code Indian Railway General	-	1	1	1	-
18	Indian Railway Establishment Manual	-	1	1	1	1
19	Indian Railway Permanent Way Manual	1	1	1	1	1
20	Indian Railway works Manual	1	1	1	1	1
21	Indian Railway Bridge Manual	1	1	1	1	1
22	Manual ,Signaling and Interlocking	-	1	1	-	-
23	Manual, Accidents or circulars Pertaining to accident.	1	1	1	1	1
24	Price lists of Stores or Stores Nomenclature and circulars as applicable	-	1	1	1	1

1	2	3	4	5	6	7
25	Red Tariff No. 16, Indian Railway Conference Association	-	1	1	1	-
26	Regulations, Hours of Employment with notifications as issued	-	1	1	1	1
27	Rules, General and subsidiary parts I & II	1	1	1	1	1
28	Rules reg. Leave, Passes & PTOs	-	1	1	1	1
29	"Safety First" rules.	1	1	1	1	1
30	Schedule of Dimensions.	1	1	1	1	1
31	Schedule of Powers of Divisional & Asst. Engineers.	-	-	1	1	-
32	Special Orders on matters of general importance concerning the staff as issued.	1	1	1	1	1
33	Standing orders- Operating Department.	-	1	1	-	-
34	Telegraph Code.	-	1	1	1	1
35	Works Hand book of general Conditions of Contract and Specifications for Materials and Works	-	1	1	1	1

1	2	3	4	5	6	7
36	Working of Cranes and Hoists, as issued.	-	1	1	1	1
37	Chief Engineer's Circulars on Bridges.	-	1	1	1	1
38	River Training and Protection Work for Railway Bridges- Monograms by IRICEN Pune.	-	1	1	-	-
39	Monsoon Instructions issued by the Railway.	-	1	1	1	1
40	IRS Code of Practice for the Design of sub-structures and foundations of bridges.	-	1	1	1	-
41	Code of practice for design and construction, of Pile foundation (4 parts) IS:2911	-	1	1	-	-
42	Gauging Manual issued by RDSO	-	1	1	-	-

1	2	3	4	5	6	7
43	IRS Code of practice for fabrication and erection of steel work for Microwave towers(self Supporting type)	-	1	1	1	-
44	Manual of Inspection and Maintenance of Concrete Bridges issued by RDSO(1990).	-	1	1	1	1
45	Arch Bridge code 1982	-	1	1	-	-
46	Report of the sub-committee on the rebuilding of Railway Bridges-RDSO	-	1	1	-	-
47	Bridge Inspection and maintenance by IRICEN/Pune.	-	1	1	1	1
48	Report of the committee on Numerical Ratings of Bridges	-	1	1	1	-
49	Guidelines on fabrication of welded Bridge Girders(Report No. c-277), March'94 issued by RDSO.	-	1	-	-	1

1	2	3	4	5	6	7
50	Study made to reduce frequency of painting of Railway steel bridge girders/ structures	-	1	1	1	1
51	Quality Assurance Programme for prestressed concrete construction issued by RDSO(1991)	-	1	1	1	1
52	Guidelines for Inspection, Maintenance and Rehabilitation of long Span prestressed concrete bridges issued by RDSO (July 1993)	-	1	1	1	1
53	Maintenance and Rehabilitation of masonry bridges issued by RDSO (August 93)	-	1	1	1	1
54	Guidelines for inspection and maintenance of Welded Bridge girders issued by RDSO (December 90)	-	1	1	1	1